



Digimatic Indicators



Dial Indicators



Dial Test Indicators



Dial Indicator Applications and Stands



INDEX

Digimatic Indicators	
ABSOLUTE Digimatic Indicator ID-S	F-2
ABSOLUTE Digimatic Indicator ID-U	F-3
ABSOLUTE Digimatic Indicator ID-C	F-4 - 9
ABSOLUTE Digimatic Indicator ID-H	F-10
ABSOLUTE Digimatic Indicator ID-F	F-11
ABSOLUTE Digimatic Indicator ID-N/B	F-12
EC Counter	F-13
Dial Indicator	
Dial Indicators	F-14 - 20
Special Dial Indicators	F-21
Dial Indicators	F-22 - 29
Back Plunger Type Dial Indicators	F-30, 31
Backs, Contact Points (Optional Accessories)	F-32 - 34
Spindle Lifting Lever and Cable (Optional Accessories)	F-35
Color Spindle Caps	F-36
Limit Stickers	F-36
Dial Indicator Repair Tool Kit	F-37
Dial Indicator Crystal Setter	F-37
Dial Test Indicators	F-38 - 42, 45
Pocket Type Dial Test Indicators	F-43, 44
Contact Points and Clamp Holders (Optional Accessories)	F-46
Dial Indicator Applications	
i-Checker	F-47
UDT-2 Dial Gage Testers	F-48
Calibration Testers	F-48
Thickness Gages	F-49 - 52
Quick-Mini	F-53
Digimatic Caliper Gages	F-54, 55
Dial Caliper Gages	F-56 - 58
Dial Tension Gages	F-59
V-Block Sets	F-59
Magnetic V-Block	F-59
Dial Snap Gages	F-60
Stands	
Dial/Digimatic Indicator & Magnetic Stand Sets	F-61
Magnetic Stands	F-61
Dial Gage Stands	F-62
Transfer Stand	F-63
Roll Caliper	F-63
Precision Granite Stands	F-64
Comparator Stands	F-64

ABSOLUTE Digimatic Indicator ID-S

SERIES 543 — with Simple Design

FEATURES

- As compact as standard Series 2 dial indicators.
- After the initial zero-setting with the ORIGIN button, the repeated absolute positioning is no longer necessary over the entire battery life.
- Employing the ABSOLUTE linear encoder, the ID-S always displays the spindle "Absolute Position" from the origin at power-on. Also unlimited response speed eliminates over-speed errors.
- SPC data output.



543-683B



543-690



SPECIFICATIONS

Inch/Metric Stem dia. 3/8", #4-48 UNF Thread ISO/JIS type ANSI/AGD type

Resolution	Range	Order No.		Model	Accuracy	Measuring force	Remarks
		w/ lug back	w/ flat-back				
.00005"/0.001mm	.5" / 12.7mm	543-692	543-692B	ID-S112E	.00012"	2.0N	—
.00005"/0.001mm	.5" / 12.7mm	543-696	543-696B	ID-S112PE	.00012"	2.5N	Dust-proof
.0001"/0.001mm	.5" / 12.7mm	543-693	543-693B	ID-S112T	.00012"	2.0N	—
.0005"/0.01mm	.5" / 12.7mm	543-683	543-683B	ID-S1012E	.0008"	2.0N	—

Inch/Metric Stem ø 8mm, M2.5 x 0.45 Thread

Resolution	Range	Order No.		Model	Accuracy	Measuring force	Remarks
		w/ lug back	w/ flat-back				
.00005"/0.001mm	.5" / 12.7mm	543-691	543-691B	ID-S112M	.00012"	2.0N or less	—
.00005"/0.001mm	.5" / 12.7mm	543-695	543-695B	ID-S112PM	.00012"	2.5N or less	Dust-proof
.0005"/0.01mm	.5" / 12.7mm	543-682	543-682B	ID-S1012M	.0008"	2.0N or less	—

Metric Stem ø 8mm, M2.5 x 0.45 Thread

Resolution	Range	Order No.		Model	Accuracy	Measuring force	Remarks
		w/ lug back	w/ flat-back				
0.001mm	12.7mm	543-690	543-690B	ID-S112	0.003mm	2.0N or less	—
0.001mm	12.7mm	543-694	543-694B	ID-S112P	0.003mm	2.5N or less	Dust-proof
0.01mm	12.7mm	543-681	543-681B	ID-S1012	0.02mm	2.0N or less	—

DIMENSIONS

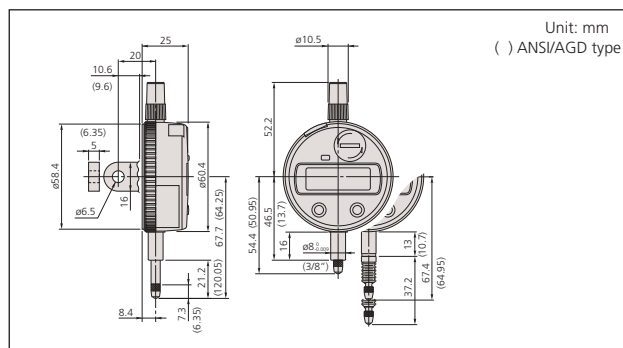

Technical Data

Accuracy: Refer to the list of specifications
 Resolution: 0.01mm, 0.001mm, .0005"/0.01mm, .0001"/0.001mm or .00005"/0.001mm
 Display: LCD
 Length standard: ABSOLUTE electrostatic capacitance type linear encoder
 Max. response speed: Unlimited
 Measuring force: Refer to the list of specifications
 Battery: SR44 (1 pc.), **938882**
 Battery life: Approx. 20,000 hours under normal use
 Dust/Water protection level: IP42 (IP53: **543-694, 543-695, 543-696**)

Function

Origin-set, Zeraset, Counting direction switching, Power ON/OFF, Data output, inch/mm conversion (on inch/metric models only)
 Alarm: Low voltage, Counting value composition error, Over-flow error

Optional Accessories

- 905338:** SPC cable (40" / 1m)
- 905409:** SPC cable (80" / 2m)
- 903424:** Spindle lifting lever (ISO/JIS type)
- 903425:** Spindle lifting lever (ANSI/AGD type)
- 540774:** Spindle lifting cable (stroke: .4" / 10mm)
- 125317:** Spare rubber boot (for dust-proof type)
- 02ACB420:** Lug-on-center back for ISO/JIS type
- 02ACB430:** Lug-on-center back for AGD type
- 02ACB440:** Flat back
- 02ACB610:** Back with post
- 02ACB620:** Adjustable back for AGD type
- 02ACB630:** Adjustable back (ISO/JIS type)
- 02ACB640:** Back with offset lug
- 02ACB650:** Magnetic back
- 02ACB660:** Back with screw mount for AGD type
- 02ACB670:** Back with screw mount (ISO/JIS type)
- 02ACB680:** Back with adjustable bracket
- : Contact points (See page F-33.)





ABSOLUTE[®]

Absolute System Patented by MITUTOYO

Technical Data

Accuracy: Refer to the list of specifications
 Resolution: 0.01mm or .0005"/0.01mm,
 Display: LCD
 Length standard: ABSOLUTE electrostatic capacitance type
 linear encoder
 Max. response speed: Unlimited
 Measuring force: Refer to the list of specifications
 Battery: SR44 (1 pc.), **938882**
 Battery life: Approx. 20,000 hours under normal use
 Dust/Water protection level: IP42

Function

Origin-set, Zeroset, Counting direction switching, Power
 ON/OFF, Data output,
 inch/mm conversion (on inch/metric models only)
 Alarm: Low voltage, Counting value composition error,
 Over-flow error

Optional Accessories

905338: SPC cable (40" / 1m)
905409: SPC cable (80" / 2m)
540774: Spindle lifting cable (stroke: .4" / 10mm)
 _____: Contact points (See page F-33.)

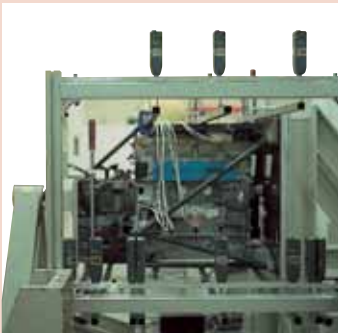

Application example

ABSOLUTE Digimatic Indicator ID-U

SERIES 575 — with Slim and Simple Design

FEATURES

- Slim type digital indicator with low price.
- Large LCD and simple key operation.
- After the initial origin setting, the ID-U no longer needs absolute positioning over the entire battery life; the origin is remembered even after power-off.
- Ideal for installation into measuring devices because of its compact design and long battery life.
- Employing the ABSOLUTE linear encoder, the ID-U always displays the spindle "Absolute Position" from the origin at power-on. Also unlimited response speed eliminates over-speed errors.
- Flat back type only no option for backs.
- SPC data output.



SPECIFICATIONS

Inch/Metric Stem dia. 3/8", #4-48 UNF Thread ISO/JIS type ANSI/AGD type

Resolution	Range	Order No.	Model	Accuracy	Measuring force
.0005"/0.01mm	1" / 25.4mm	575-123	ID-U1025E	.0008"	1.8N or less

Inch/Metric Stem ø 8mm, M2.5 x 0.45 Thread

Resolution	Range	Order No.	Model	Accuracy	Measuring force
.0005"/0.01mm	1" / 25.4mm	575-122	ID-U1025M	.0008"	1.8N or less

Metric Stem ø 8mm, M2.5 x 0.45 Thread

Resolution	Range	Order No.	Model	Accuracy	Measuring force
0.01mm	25.4mm	575-121	ID-U1025	0.02mm	1.8N or less

DIMENSIONS

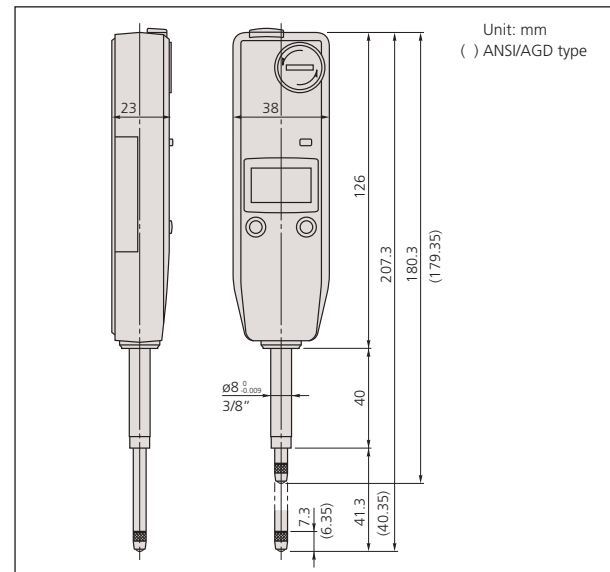

ABSOLUTE Digimatic Indicator ID-C

SERIES 543 — Standard Type

FEATURES

- As compact as standard Series 2 dial indicators.
- Large, easy-to-read LCD.
- GO/±NG judgment can be performed by setting upper and lower tolerance limits. The judgment result (GO/±NG) can be displayed in full-size characters.
- The positive/negative count resulting from the spindle's up/down movement can be toggled.
- Internal calculations using the simple formula of $[F(x) = Ax]$ are available.
- Employing the ABSOLUTE linear encoder, the ID-C always displays the spindle "Absolute Position" from the origin at power-on. Also unlimited response speed eliminates over-speed errors.
- The ID-C indicator face can be rotated 330° to an appropriate angle for easy reading.
- With SPC data output.



Technical Data

Accuracy: Refer to the list of specifications

Resolution:	0.01mm type	0.01mm
	0.001mm type*	0.001mm/0.01mm
	.0005"/0.01mm type	.0005"/0.01mm
	.00005"/0.001mm type*	.0005"/.0001"/.00005"/0.01mm/0.001mm

* Switchable resolution

Display: LCD

Length standard: ABSOLUTE electrostatic capacitance type linear encoder

Max. response speed: Unlimited

Measuring force: Refer to the list of specifications

Battery: SR44 (1 pc.), **938882**

Battery life: Approx. 5,000 hours under normal use

Dust/Water protection level: IP42 or IP53 (dust-proof type)

Function

Origin-set/Preset, Zeroset, GO/±NG judgment, Counting direction switching, Power ON/OFF, Data output, inch/mm conversion (on inch/metric models only)

Alarm: Low voltage, Counting value composition error, Over-flow error, Tolerance limit setting error

Internal calculations using the simple formula of $[F(x) = Ax]$ are available.

Optional Accessories

905338: SPC cable (40" / 1m)

905409: SPC cable (80" / 2m)

21EZA198: Spindle lifting lever (ISO/JIS type)*

21EZA199: Spindle lifting lever (ANSI/AGD type)*

21EZA105: Spindle lifting knob (12.7mm/.5"ISO/JIS type)**

21EZA150: Spindle lifting knob(12.7mm/.5"ANSI/AGD type)**

21EZA197: Spindle lifting knob (25.4mm/1", 50.8mm/2" models)

21EZA200: Spindle lifting knob (50.8mm/2")

540774: Spindle lifting cable (stroke: (1"/25.4mm)

02ACA571: Auxiliary spindle spring for 25mm/1" models***

02ACA773: Auxiliary spindle spring for 50mm/2" models***

——: Backs (See page F-32.)

——: Contact points (See page F-33.)

* Can be used on 12mm/.5" models only.

** Not available for low measuring force models.

*** Required when orienting gage upside down.

330° Rotary display

The display can be rotated 330°, allowing use at a position where you can easily read the measurement value.



Calculation: $f(x) = Ax$

Mounting the ID-C on a measuring jig and setting the multiplying factor 'A' (to any value) allows direct measurement without using a conversion table and improves measurement efficiency.



Application example

Function locking

Ensures reliability of measurement by locking the settings to prevent preset function settings from being changed by mistake.



Setting measuring force on low measuring force models

•543-404/404B/405/405B/406/406B

Spindle orientation	Spring	Weight (approximately 0.1N)	Maximum measuring force
Pointing vertically downward	Yes	Yes	0.5N
	Yes	No	0.4N
	No	Yes	0.3N
	No	No	0.2N
Horizontal	Yes	No	0.2N

Note) Operation using configurations other than shown above is not guaranteed.

•543-394/394B/395/395B/396/396B

Spindle orientation	Spring	Weight (approximately 0.1N)	Maximum measuring force
Pointing vertically downward	Yes	Yes	0.7N
	Yes	No	0.6N
	No	Yes	0.4N
	No	No	Not guaranteed
Horizontal	Not guaranteed		

Note) Operation using configurations other than shown above is not guaranteed.

SPECIFICATIONS

Inch/Metric		Stem dia. 3/8", #4-48 UNF Thread		ISO/JIS type	ANSI/AGD type		
Resolution	Range	Order No. (w/lug, flat-back)		Model	Accuracy	Measuring force	Remarks
.00005"/0.001mm*	.5" / 12.7mm	543-392	543-392B	ID-C112EXB	.0001"	1.5N or less	—
.00005"/0.001mm*	.5" / 12.7mm	543-396	543-396B	ID-C112CEX	.0001"	0.4N - 0.7N	Low measuring force
.00005"/0.001mm*	1" / 25.4mm	—	543-472B	ID-C125EXB	.0001"	1.8N or less	—
.00005"/0.001mm*	2" / 50.8mm	—	543-492B	ID-C150EXB	.0002"	2.3N or less	—
.0005"/0.01mm	.5" / 12.7mm	543-402	543-402B	ID-C1012EX	.001"	0.9N or less	—
.0005"/0.01mm	.5" / 12.7mm	543-406	543-406B	ID-C1012CEX	.001"	0.2N - 0.5N	Low measuring force
.0005"/0.01mm	1" / 25.4mm	—	543-476B	ID-C1025EXB	.001"	1.8N or less	—
.0005"/0.01mm	2" / 50.8mm	—	543-496B	ID-C112CEXB	.0016"	2.3N or less	—

* Switchable Resolution Type

Inch/Metric Stem ø 8mm, M2.5 x 0.45 Thread

Resolution	Range	Order No. (w/lug, flat-back)		Model	Accuracy	Measuring force	Remarks
.00005"/0.001mm*	.5" / 12.7mm	543-391	543-391B	ID-C112MX	.0001"	1.5N or less	—
.00005"/0.001mm*	.5" / 12.7mm	543-395	543-395B	ID-C112CMX	.0001"	0.4N - 0.7N	Low measuring force
.00005"/0.001mm*	1" / 25.4mm	—	543-471B	ID-C125MXB	.0001"	1.8N or less	—
.00005"/0.001mm*	2" / 50.8mm	—	543-491B	ID-C150MXB	.0002"	2.3N or less	—
.0005"/0.01mm	.5" / 12.7mm	543-401	543-401B	ID-C1012MX	.001"	0.9N or less	—
.0005"/0.01mm	.5" / 12.7mm	543-405	543-405B	ID-C1012CMX	.001"	0.2N - 0.5N	Low measuring force
.0005"/0.01mm	1" / 25.4mm	—	543-475B	ID-C1025MXB	.001"	1.8N or less	—
.0005"/0.01mm	2" / 50.8mm	—	543-495B	ID-C1050MXB	.0016"	2.3N or less	—

* Switchable Resolution Type

Metric Stem ø 8mm, M2.5 x 0.45 Thread

Resolution	Range	Order No. (w/lug, flat-back)		Model	Accuracy	Measuring force	Remarks
0.001mm*	12.7mm	543-390	543-390B	ID-C112X	0.003mm	1.5N or less	—
0.001mm*	12.7mm	543-394	543-394B	ID-C112CX	0.003mm	0.4N - 0.7N	Low measuring force
0.001mm*	25.4mm	—	543-470B	ID-C125XB	0.003mm	1.8N or less	—
0.001mm*	50.8mm	—	543-490B	ID-C150XB	0.006mm	2.3N or less	—
0.01mm	12.7mm	543-400	543-400B	ID-C1012X	0.02mm	0.9N or less	—
0.01mm	12.7mm	543-404	543-404B	ID-C1012CX	0.02mm	0.2N - 0.5N	Low measuring force
0.01mm	25.4mm	—	543-474B	ID-C1025XB	0.03mm	1.8N or less	—

* Switchable Resolution Type

DIMENSIONS

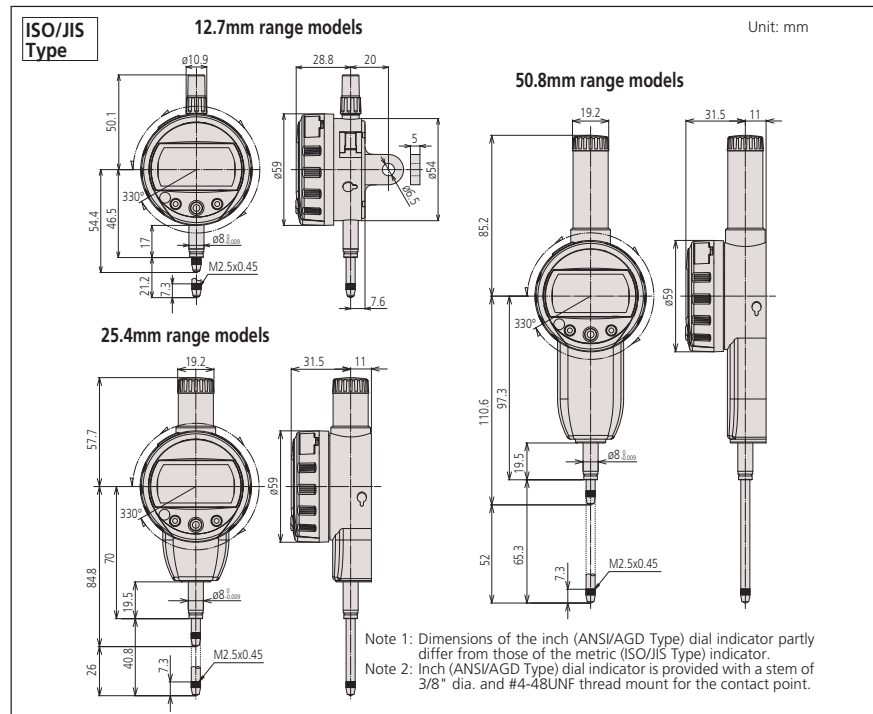

ABSOLUTE Digimatic Indicator ID-C

SERIES 543 — Calculation Type

FEATURES

A conventional Digimatic indicator simply displays a spindle displacement, but the Calculation-Type Digimatic indicator incorporates an internal calculation function in place of spindle displacement. With fixtures, measurements such as feeler, inside diameter and radius of curvature measurement can easily be obtained without the hassle of conversion tables or equivalents.

- The Absolute Digimatic indicator performs internal calculations using the formula $Ax+B+Cx^{-1}$ (assuming spindle displacement as x) while the specified coefficients A , B and C can be set with respect to the purpose of measurement or dimensions of the fixtures. This unique features allows you to read your measurements directly, without fumbling for conversions.



SPECIFICATIONS

ISO/JIS type ANSI/AGD type

Inch/Metric Stem dia. 3/8" #4-48 UNF Thread

Resolution	Range	Order No.*	Model	Accuracy	Measuring Force
.00001" - .05"/ 0.0002 - 1mm (switchable)	.5" / 12.7mm	543-287B	ID-C112REB	.00012"	1.5N or less
	1" / 25.4mm	543-482B	ID-C125REB	.00012"	2.0N or less
	2" / 50.8mm	543-487B	ID-C150REB	.00025"	2.3N or less

Inch/Metric Stem \varnothing 8mm, M2.5 x 0.45 Thread

Resolution	Range	Order No.*	Model	Accuracy	Measuring Force
.00001" - .05"/ 0.0002 - 1mm (switchable)	.5" / 12.7mm	543-286B	ID-C112RMB	.00012"	1.5N or less
	1" / 25.4mm	543-481B	ID-C125RMB	.00012"	2.0N or less
	2" / 50.8mm	543-486B	ID-C150RMB	.00025"	2.3N or less

Metric Stem \varnothing 8mm, M2.5 x 0.45 Thread

Resolution	Range	Order No.*	Model	Accuracy	Measuring Force
0.0002 - 1mm (switchable)	12.7mm	543-285B	ID-C112RB	0.003mm	1.5N or less
	25.4mm	543-480B	ID-C125RB	0.003mm	2.0N or less
	50.8mm	543-485B	ID-C150RB	0.006mm	2.3N or less

*Flat back

DIMENSIONS

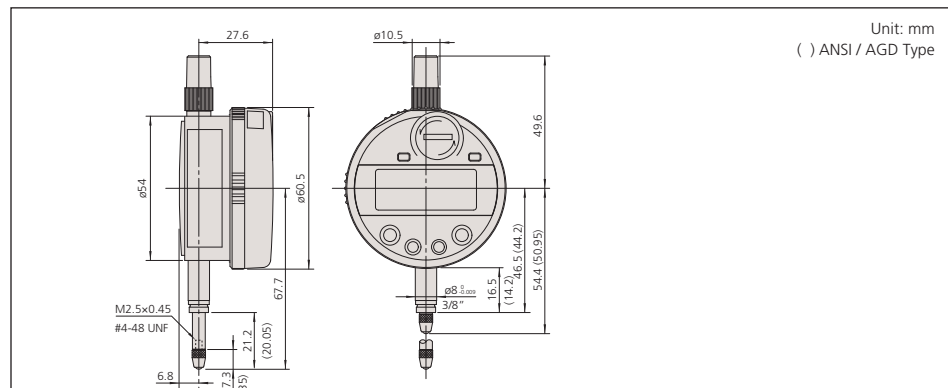

Technical Data

Accuracy: Refer to the list of specifications
 Resolution: 0.0002mm - 1mm or
 .00001" - .05"/0.0002mm - 1mm
 Display: LCD
 Length standard: ABSOLUTE electrostatic capacitance type
 linear encoder
 Max. response speed: Unlimited
 Measuring force: 1.5N or less
 Battery: SR44 (1 pc.), **938882**
 Battery life: Approx. 12 months under normal use

Function

Origin-set/Preset, Zeroset, GO/NG judgment, Counting direction switching, Power ON/OFF, Data output, inch/mm conversion (on inch/metric models only)
 Alarm: Low voltage, Counting value composition error, Over-flow error, Tolerance limit setting error

Optional Accessories

- 905338:** SPC cable (40" / 1m)
- 905409:** SPC cable (80" / 2m)
- 902011:** Spindle lifting lever (ISO/JIS type)
- 540774:** Spindle lifting cable (Stroke: .4" / 10mm)
- Backs (See page F-32.)
- Contact points (See page F-33.)

APPLICATIONS



- Various fixtures suited for individual workpieces can be prepared.
- Measuring accuracy is subject to fixture accuracy



Technical Data

Accuracy: Refer to the list of specifications
 Resolution: 0.001mm, .00005"/0.001mm or .0001"/0.001mm
 Display: LCD
 Length standard: ABSOLUTE electrostatic capacitance type linear encoder
 Max. response speed: Unlimited
 Measuring force: 2.0N or less
 Power supply: DC 12 - 24V±10%
 Dust/Water protection level: IP54

Function

Data output (-NG/OK/NG signal, NPN open collector), Remote control (hold-preset, preset-recall, zero-set), Origin-set/Preset, Zeroset, GO/±NG judgment, Max/Min/Runout value holding, Counting direction switching, Power ON/OFF, inch/mm conversion (on inch/metric models only)
 Alarm: Low voltage, Counting value composition error, Over-flow error, Tolerance limit setting error

Optional Accessories

- 902011: Spindle lifting lever* (ISO/JIS type)
- 902794: Spindle lifting lever* (ANSI/AGD type)
- 540774: Spindle lifting cable* (Stroke: .4" / 10mm)
- 125317: Rubber boot
- : Backs (See page F-32.)
- : Contact points (See page F-33.)

*When using the spindle lifting lever/cable, IP54 is not guaranteed.

Output pattern

Wire	- NG	OK	+ NG	Composition error
Orange (- NG)	Low	High	High	High
Green (OK)	High	Low	High	High
Brown (+ NG)	High	High	Low	High
LED	Red	Green	Red	Red (blinking)
LCD	<	O	>	" x.xxE" indication

I/O Specifications

Wire	Signal	I/O	Description
Black	- V (GND)	—	Connected to minus (-) terminal
Red	+ V (GND)	I	Power supply (12 - 24VDC)
Orange	- NG	O	Tolerance judgment result output: Only the terminal corresponding to a judgment result is set to the below level.
Green	OK	O	
Brown	+ NG	O	
Yellow	PRESET_RECALL ZERO	I	External input terminal: If the relevant terminal is set to the low level, its signal becomes true.
Blue	HOLD_RESET	I	
Shield	FG	—	Connected to GND

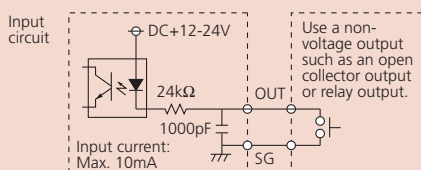
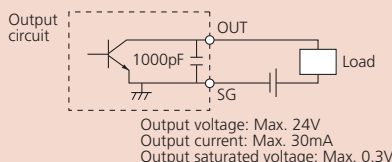

ABSOLUTE Digimatic Indicator ID-C

SERIES 543 — with Green/Red LED and GO/NG Signal Output Function

FEATURES

- With the max./min. value holding function, the signal ID-C can output the signal of the GO/±NG judgment result against the peak values set. Substitute for the mechanical/electrical contact, the judgment is carried out by calculating the measurement data obtained. This provides high reliability with no deterioration of the contact point and volume adjustment.
- The signal can be output to an external device like a sequencer through the NPN open-collector.
- The GO/±NG judgment result is also indicated by the green/red LED and the "<, O, >" signs on LCD.
- Employing the ABSOLUTE linear encoder, the Signal ID-C always displays the spindle "Absolute Position" from the origin at power-on.
- The Signal ID-C achieves the IP54 protection level to resist dust and contaminants for safe operation in harsh machine shop environments.



SPECIFICATIONS

Inch/Metric		Stem dia. 3/8" #4-48 UNF Thread		ISO/JIS type	ANSI/AGD type
Resolution	Range	Order No. (w lug, flat-back)	Model	Accuracy	Measuring force
.00005"/0.001mm	.5" / 12.7mm	543-282	543-282B	ID-C112JE	.00012" / 2.0N or less
.0005"/0.01mm	.5" / 12.7mm	543-283	543-283B	ID-C112JT	.00012" / 2.0N or less

Inch/Metric		Stem ø 8mm, M2.5 x 0.45 Thread			
Resolution	Range	Order No. (w lug, flat-back)	Model	Accuracy	Measuring force
.00005"/0.001mm	.5" / 12.7mm	543-281	543-281B	ID-C112JM	.00012" / 2.0N or less

Metric		Stem ø 8mm, M2. x 0.45 Thread			
Resolution	Range	Order No. (w lug, flat-back)	Model	Accuracy	Measuring force
0.001mm	12.7mm	543-280	543-280B	ID-C112J	0.003mm / 2.0N or less

DIMENSIONS

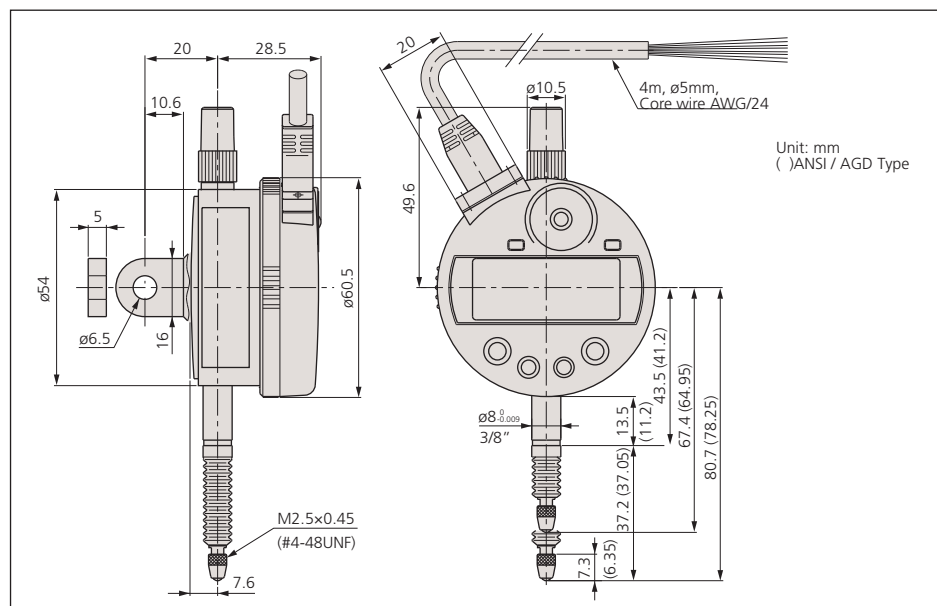

ABSOLUTE Digimatic Indicator ID-C

SERIES 543 — with Max./Min. Value Holding Function

With max./min. value holding function model of the ID-C Series Digimatic Indicators.

FEATURES

- The maximum, minimum, or runout value can be displayed during measurement.
- GO/±NG judgment is performed by setting the upper and lower tolerances for max., min. and runout values.
- High speed sampling ratio of 50 times/s.
- Employing the ABSOLUTE linear encoder, the Signal ID-C always displays the spindle "Absolute Position" from the origin at power-on.



543-260

SPECIFICATIONS

ISO/JIS type ANSI/AGD type

Inch/Metric		Stem dia. 3/8" #4-48 UNF Thread		
Resolution	Range	Order No.*	Model	Accuracy
.00005"/0.001mm	.5" / 12.7mm	543-262	ID-C112AE	.00012"
.0001"/0.001mm	.5" / 12.7mm	543-263	ID-C112AT	.00012"

Inch/Metric		Stem ø 8mm, M2.5 x 0.45 Thread		
Resolution	Range	Order No.*	Model	Accuracy
.00005"/0.001mm	.5" / 12.7mm	543-261	ID-C112AM	.00012"

*Back with lug

Metric		Stem ø 8mm, M2.5 x 0.45 Thread		
Resolution	Range	Order No.*	Model	Accuracy
0.001mm	12.7mm	543-260	ID-C112A	0.003mm

*Back with lug

DIMENSIONS

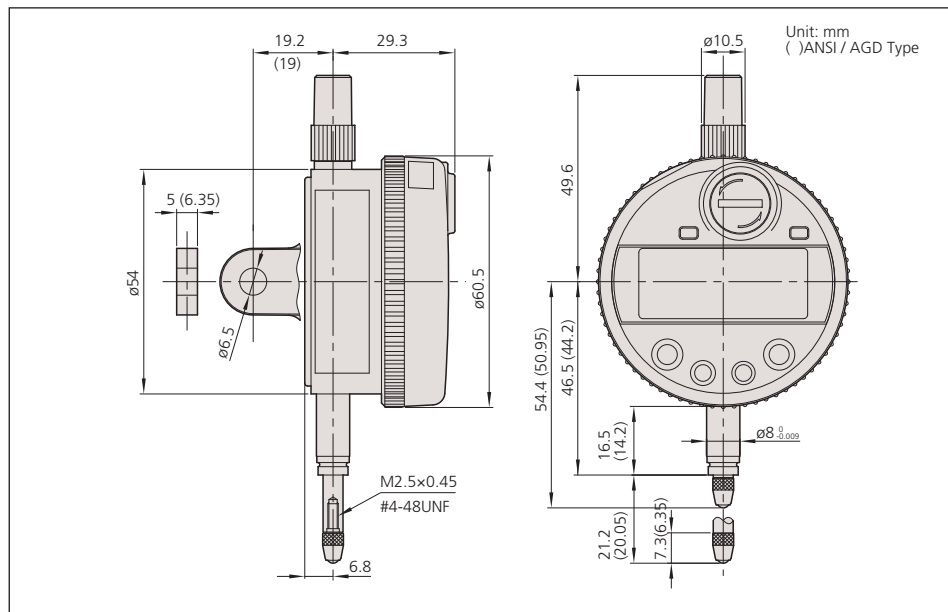

Technical Data

Accuracy: Refer to the list of specifications
 Resolution: 0.001mm, .00005"/0.001mm or .0001"/0.001mm
 Display: LCD
 Length standard: ABSOLUTE electrostatic capacitance type linear encoder
 Max. response speed: Unlimited
 Measuring force: 1.5N or less
 Battery: SR44 (2 pcs.), **938882**
 Battery life: Approx. 800 - 1300 hours under normal use
 Dust/Water protection level: IP42

Function

Origin-set/Preset, Zeroset, GO/±NG judgment, Max/Min/Runout value holding, Counting direction switching, Power ON/OFF, Data output, inch/mm conversion (on inch/metric models only)
 Alarm: Low voltage, Counting value composition error, Over-flow error, Tolerance limit setting error

Optional Accessories

- 905338: SPC cable (40" / 1m)
- 905409: SPC cable (80" / 2m)
- 902011: Spindle lifting lever (ISO/JIS type)
- 902794: Spindle lifting lever (ANSI/AGD type)
- 540774: Spindle lifting cable (stroke: .4" / 10mm)
- : Backs (See page F-32.)
- : Contact points (See page F-33.)



Technical Data

Accuracy: Refer to the list of specifications
 Resolution: 0.001mm or .00005"/0.001mm
 Display: LCD
 Length standard: ABSOLUTE electrostatic capacitance type linear encoder
 Max. response speed: Unlimited
 Measuring force: 1.5N or less
 Battery: SR44 (2 pcs.), **938882**
 Battery life: Approx. 2000 hours under normal use
 Dust/Water protection level: IP42

Function

Origin-set/Pre-set, Zero-set, GO/±NG judgment, Power ON/OFF, Data output, inch/mm conversion (on inch/metric models only)
 Alarm: Low voltage, Counting value composition error, Over-flow error, Tolerance limit setting error

Optional Accessories

905338: SPC cable (40" / 1m)
905409: SPC cable (80" / 2m)
 Applicable Gages Series 511 and 526



Installed on bore gage probe (511-127)

ABSOLUTE Digimatic Indicator ID-C

SERIES 543 — Specially Designed for Bore Gage Application

This ID-C Series Digimatic Indicators are exclusively designed for ID measurement.

FEATURES

- The minimum value holding function provides the easy of detection of hole diameter.
- An analog bar indicator is integrated to enhance the intuition in reading.
- GO/±NG judgment is performed by setting the upper and lower tolerances.
- Up to three sets of master value and upper/lower tolerance value can be memorized.
- Employing the ABSOLUTE linear encoder, the Signal ID-C always displays the spindle "Absolute Position" from the origin at power-on.



543-266B

SPECIFICATIONS

ISO/JIS type ANSI/AGD type

Inch/Metric Stem dia. 3/8" #4-48 UNF Thread

Resolution	Range	Order No.*	Model	Accuracy
.00005"/0.001mm	.5" / 12.7mm	543-266B	ID-C112GE	.00012"
.0001"/0.001mm	.5" / 12.7mm	543-267B	ID-C112G	.00012"

*Back with lug

Metric Stem ø 8mm, M2.5 x 0.45 Thread

Resolution	Range	Order No.*	Model	Accuracy
0.001mm	12.7mm	543-264B	ID-C112G	0.003mm

*Back with lug

DIMENSIONS

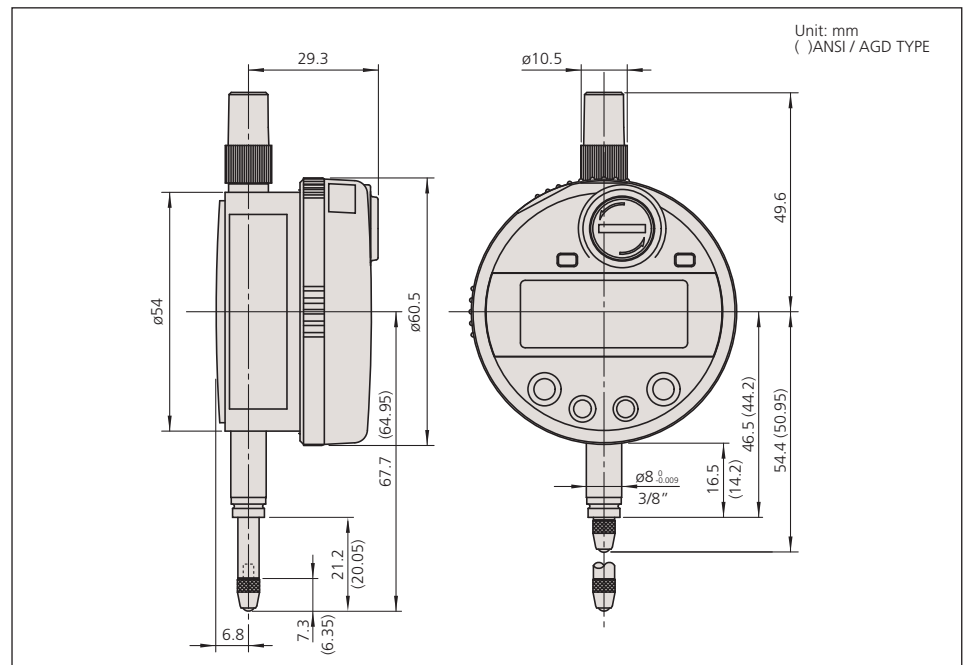

ABSOLUTE Digimatic Indicator ID-H

SERIES 543 — High Accuracy and High Functional Type



FEATURES

- This new-generation digital indicator offers the excellent accuracy and functionality expected from this class of indicator. Take advantage of its high accuracy backed up by 0.5 μ m / .00002" resolution, remote control functionality via a handheld controller (or an RS-232C interface) and easy runout measurements with the well-established analog bar display.
- The maximum, minimum, or runout value can be displayed during measurement.
- GO/ \pm NG judgment is performed by setting the upper and lower tolerances. If a judgment result is out of tolerance, the display backlighting changes from green to red, so tolerance judgment can be made at a glance.
- With SPC data output.
- With RS-232C input/output



SPECIFICATIONS

Inch/Metric Stem dia. 3/8" #4-48 UNF Thread

Resolution	Range	Order No.*	Model	Accuracy
.00002", .00005", .0001", 0.0005mm, 0.001mm	1.2" / 30.4mm 2.4" / 60.9mm	543-562A 543-564A	ID-H530E ID-H560E	0.0015mm 0.0025mm

Metric Stem ϕ 8mm M2.5 X 0.45 Thread

Resolution	Range	Order No.*	Model	Accuracy
0.0005mm, 0.001mm	30.4mm 60.9mm	543-561A 543-563A	ID-H530 ID-H560	0.0015mm 0.0025mm

DIMENSIONS

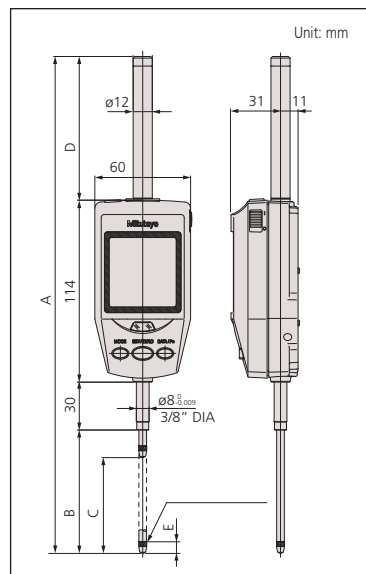

Tolerance judgment



Analog bar display



Max/Min value measurement



Runout measurement



Resolution switching



Technical Data

Accuracy: Refer to the list of specifications
 Resolution: 0.0005mm/0.001mm or .00002"/.00005"
 /.0001"/0.0005mm/0.001mm
 Display: LCD
 Length standard: Linear encoder
 Max. response speed: 1000mm/s
 Measuring force: 2.0N/2.5N* or less (*60mm range models)
 Power supply: 6V DC (via AC adaptor)

Function

Origin-set/Preset, Zeroset, GO/ \pm NG judgment, Max/Min value hold, Runout measurement, Resolution switching, Counting direction switching, Power ON/OFF, Data output, inch/mm conversion (on inch/metric models only)
 Alarm: Low voltage, Counting value composition error, Over-flow error, Tolerance limit setting error

Standard Accessories

09EAA119A: AC Adapter 120V
137693: Lifting Lever

Optional Accessories

936937: SPC cable (40" / 1m)
965014: SPC cable (80" / 2m)
21EAA131: RS-232C cable (80" / 2m)
21EZA099: Remote controller
540774: Spindle lifting cable (stroke: .4" / 10mm)
21EZA101: Spindle lifting knob
264-504-5A: Digimatic Min-processor DP-1VR
543-004A: Digimatic presetter
21EZA152A: FREE PARAMETER SETTING SOFTWARE
 —: Backs (See page F-32.)
 —: Contact points (See page F-33.)

*Required when orienting the indicator upside down.

Application

Difference/Runout measurement

Example: Indicator travel from points A to D
 Difference (or Total Runout) is displayed as A. Dimensions B (maximum value) and C (minimum value) can be recalled from memory with a simple key sequence.

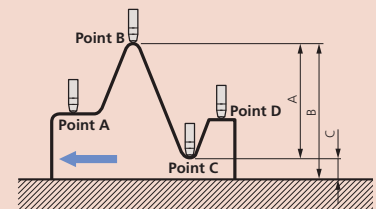

Order No.	A	B	C	D	E
543-561A	251.3	47.3	30.48	60	7.3
543-562A	250.35	46.35	30.48	60	6.35
543-563A	311.3	77.3	60.96	90	7.3
543-564A	310.35	76.35	60.96	90	6.35



Technical Data

Accuracy: Refer to the list of specifications
 Resolution: 0.01mm/0.001mm or .00005"/.0001"/.0005"
 /.001"/0.001mm/0.01mm
 Display: LCD
 Length standard: ABSOLUTE electrostatic capacitance type
 linear encoder
 Max. response speed: Unlimited
 Measuring force: 1.8N/2.3N* or less (*50mm range models)
 Power supply: 9V DC (via AC adaptor)

Function

Origin-set/Preset, Zeroset, GO/±NG judgment, Max/Min value hold, Runout measurement, Resolution switching, Counting direction switching, Power ON/OFF, Data output, inch/mm conversion (on inch/metric models only)
 Alarm: Low voltage, Counting value composition error, Over-flow error, Tolerance limit setting error

Standard Accessories

526688A: AC Adapter 120V
 137693: Lifting Lever

Optional Accessories

936937: SPC cable (40" / 1m)
 965014: SPC cable (80" / 2m)
 540774: Spindle lifting cable (stroke: .4" / 10mm)
 02ACA571: Auxiliary spindle spring for 25mm/1" models*
 02ACA773: Auxiliary spindle spring for 50mm/2" models*
 264-504-5A: Digimatic Min-processor DP-1VR
 543-004-1: Digimatic presetter
 —: Backs (See page F-32.)
 —: Contact points (See page F-33.)

*Required when orienting the indicator upside down.

Application

Difference/Runout measurement

Example: Indicator travel from points A to D

Difference (or Total Runout) is displayed as A. Dimensions B (maximum value) and C (minimum value) can be recalled from memory with a simple key sequence.

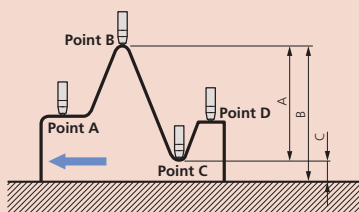

ABSOLUTE Digimatic Indicator ID-F

SERIES 543 — with Back-lit LCD Screen

FEATURES

- With the ABSOLUTE Linear Encoder technology, once the measurement reference point has been preset it will not be lost when the power is turned on.
- GO/±NG judgment is performed by setting the upper and lower tolerances. If a judgment result is out of tolerance, the display backlighting changes from green to red, so tolerance judgment can be made at a glance.
- An analog bar indicator has been integrated to handle upper/lower limit approaching and zero approaching. It enhances the ease of operation in the same manner as a dial indicator. The display range of the analog bar can be changed.
- With SPC data output.



- The maximum, minimum, or runout value can be displayed during measurement.



SPECIFICATIONS

Inch/Metric Stem dia. 3/8" #4-48 UNF Thread

Resolution	Range	Order No.*	Model	Accuracy
.00005", .0001", .0005", .001", 0.001mm, 0.01mm	1" / 25.4mm	543-552A	ID-F125E	.00012"
	2" / 50.8mm	543-558A	ID-F150HE	.00012"

Metric Stem ø 8mm M2.5 X 0.45 Thread

Resolution	Range	Order No.*	Model	Accuracy
0.001mm, 0.01mm	25mm	543-551A	ID-F125	0.003mm
	50mm	543-557A	ID-F150H	0.003mm

DIMENSIONS

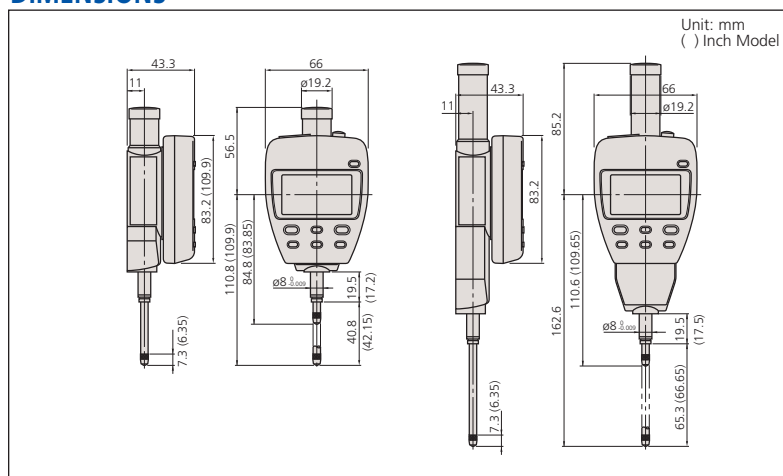

ABSOLUTE Digimatic Indicator ID-N / B

SERIES 543 — with Dust/Water Protection Conforming to IP66



FEATURES

- Proven ABSOLUTE sensor.
- Rated to IP66 water- and dust-proofing standard and oil resistance improved.
- Slim body design is advantageous for multi-point measurements.
- Improvement in workability with the LCD readout-rotation function.
- Back plunger design (ID-B).
- Built-in tolerance judgment function.
- Switchable resolution.
- Waterproof data output connector.
- Built-in hold/preset function



Slim type ID-N
543-576

Back plunger type ID-B
543-586

ID-B Digimatic Indicators

SPECIFICATIONS

Metric		Stem \varnothing 8mm M2.5 X 0.45 Thread			
Resolution	Range	Order No.	Model No.	Accuracy	Measuring Force
0.01mm	5.0mm	543-580	ID-B1005	0.02mm	2.0N or less
0.001mm	5.0mm	543-585	ID-B105	0.003mm	2.0N or less

Inch / Metric		Stem dia. 3/8" #4-48 UNF Thread			
Resolution	Range	Order No.	Model No.	Accuracy	Measuring Force
.0005" / 0.01mm	.22" / 5.6mm	543-581	ID-B1005E	.0008" / 0.02mm	2.0N or less
.0005" / 0.01mm .0005" / 0.001mm	.22" / 5.6mm	543-586	ID-B105E	.00012" / 0.003mm	2.0N or less

ID-N Digimatic Indicators

Metric		Stem \varnothing 8mm M2.5 X 0.45 Thread			
Resolution	Range	Order No.	Model No.	Accuracy	Measuring Force
0.01mm	5.0mm	543-570	ID-N1012	0.02mm	2.0N or less
0.001mm / 0.01mm	5.0mm	543-575	ID-N112	0.003mm	2.0N or less

Inch / Metric		Stem dia. 3/8" #4-48 UNF Thread			
Resolution	Range	Order No.	Model No.	Accuracy	Measuring Force
.0008" / 0.02mm	.5" / 12.7mm	543-571	ID-N1012E	.0008" / 0.02mm	2.0N or less
.00012" / 0.003mm	.5" / 12.7mm	543-576	ID-N112E	.00012" / 0.003mm	2.0N or less

DIMENSIONS AND MASS

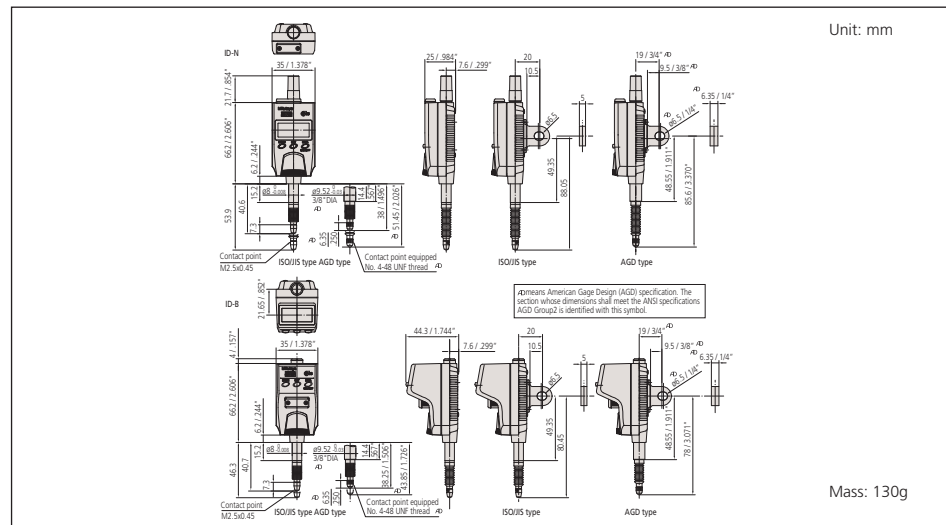

Technical Data

Accuracy: Refer to the list of specifications
 Resolution: 0.01mm, 0.01mm/0.001mm, .0005"/0.01mm or .0005"/0.0005"/0.01mm/0.001mm
 Display: LCD
 Length standard: ABSOLUTE electrostatic capacitance type linear encoder
 Max. response speed: Unlimited
 Measuring force: 2.5N (2.0N: Back plunger type)
 Battery: SR44 (1 pc.), 938882
 Battery life: Approx. 7000 hours under normal use
 Dust/Water protection level: IP66

Function

Zero-setting, Presetting, Direction switching, Tolerance judgment, Display hold, Data output, inch/mm conversion (on inch/metric models only)
 Alarm: Low voltage, Counting value composition error, Over-flow error, Tolerance limit setting error

Optional Accessories

- 21EZA105:** Lifting knob (for ISO/JIS model)
 - 21EZA150:** Lifting knob (for AGD model)
 - 21EZA145:** Lug (for JIS/ISO model)
 - 21EZA146:** Lug (for AGD model)
 - 02ACA376:** Rubber boot (for ID-N, NBR)
 - 238774:** Rubber boot (for ID-N, silicon)
 - 125317:** Rubber boot (for ID-B, NBR)
 - 21EAA212:** Rubber boot (for ID-B, silicon)
 - 21EAA194:** SPC cable (40" / 1m)
 - 21EAA190:** SPC cable (80" / 2m)
 - 21EAA210:** Bifurcated connecting cable with zero-setting terminal (40" / 1m)
 - 21EAA211:** Bifurcated connecting cable with zero-setting terminal (80" / 2m)
- : Contact points (See page F-33.)



EC Counter

SERIES 542 — Low-cost, Assembly, Type Display Unit

FEATURES

- Employed the DIN size (96 X 48mm) and mount-on-panel configuration, which greatly facilitates the incorporation into a system.
- Possible to produce either tolerance judgment output or Digimatic output.



542-007A

EC Counter

Technical Data

Applicable gage: LGD, LGS, All SPC output gages

Resolution: 0.001mm, 0.01mm

No. of gage input: 1

Display: 6-digit LED and a negative [-] sign

Function: Preset

GO/±NG judgment

Output (open-collector): 3-step limit signal, Normal signal

External control: Preset, Data hold

Power supply: Via AC adaptor

Dimensions (W x D x H): 96 x 48 x 84.6mm

Mass: 500g

Standard Accessories

526688A: AC Adapter

936937: SPC cable (40"/1m)

965014: SPC cable (80"/1m)

214938: PJ-2 (DC Plug)

C162-155: GO/±NG judgement cable

SPECIFICATIONS

Order No.	Description
542-007A	EC Counter

DIMENSIONS

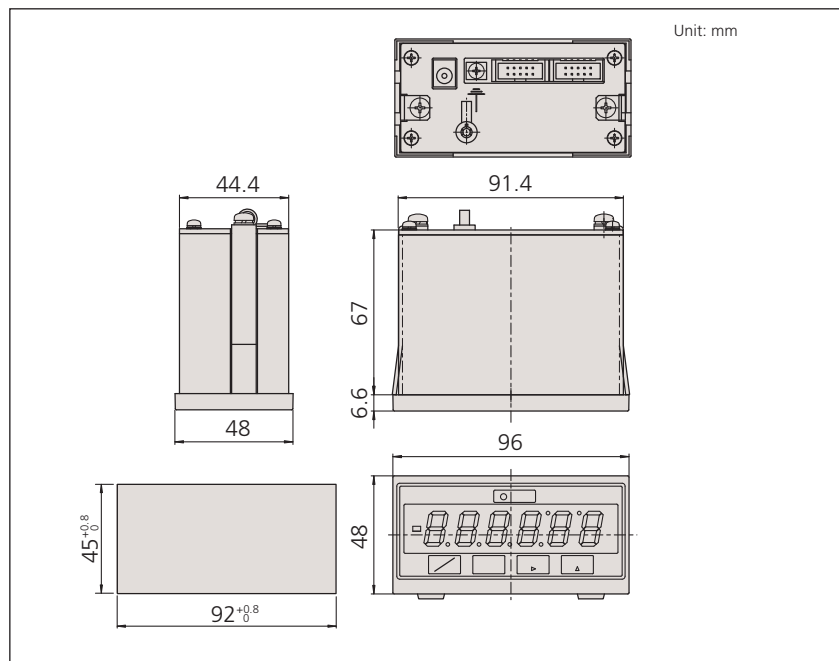

Dial Indicators

FEATURES: S Series

- Revolutionary stem-bush design for trouble free stem clamping (longer clamping range).
- No through screw-hole on the frame for high dust-resistance.

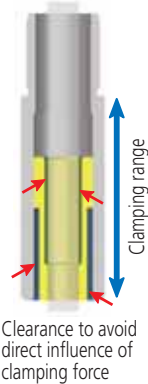

- Involute curved lifting lever for smooth movement of spindle and dovetail joint for tool-less connection.
- Greater rigidity in the bearing plate for reducing the retracing error (20%) and 4-screw mounting for increasing impact resistance.

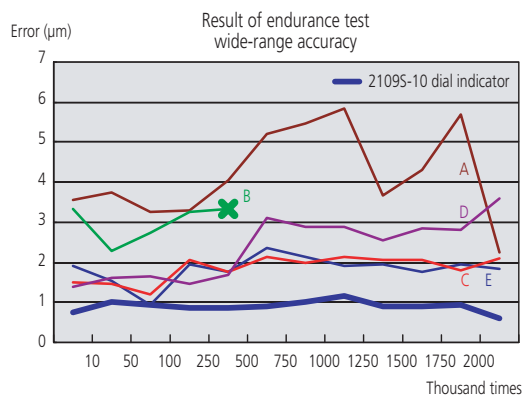
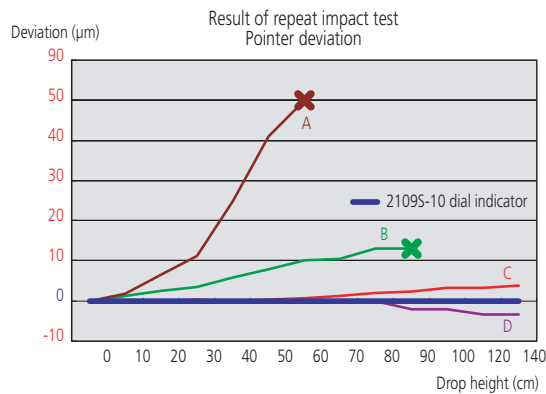
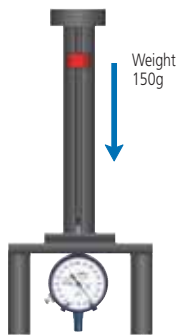
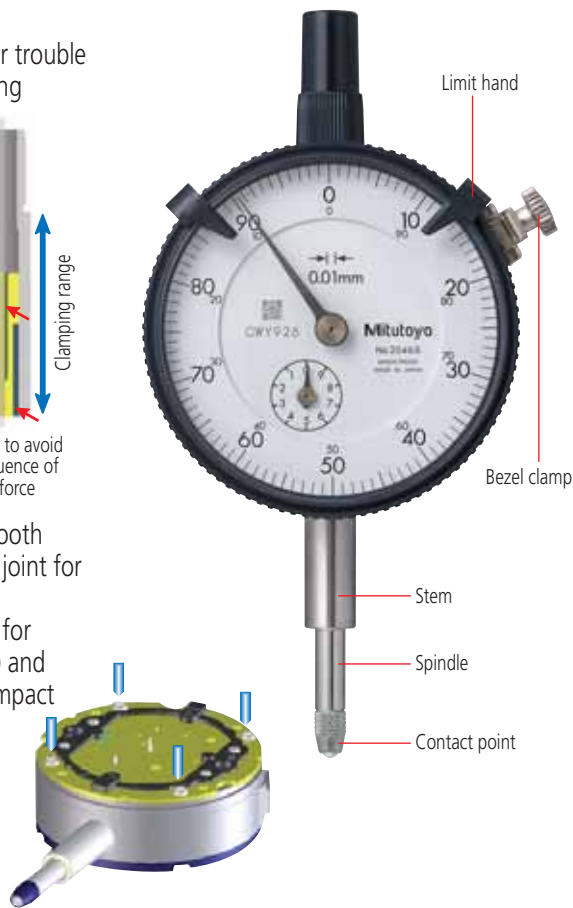

Description of Icon

Icon	Description
	Reverse reading type suitable for depth and step measurement.
	One revolution type for easy and error-free reading
	Double scale spacing type, easy-on-the-eyes
	Shockproof type
	Waterproof type
	With damper at lowest rest point
	Jeweled bearing type
	Peak retaining type
	Long stem type
	Dustproof type
	With coaxial revolution counter
	Back plunger type
	Adjustable hand type
	Double-face type

Dial Indicators

SERIES 0 - Compact type



1911



1913-10



1911

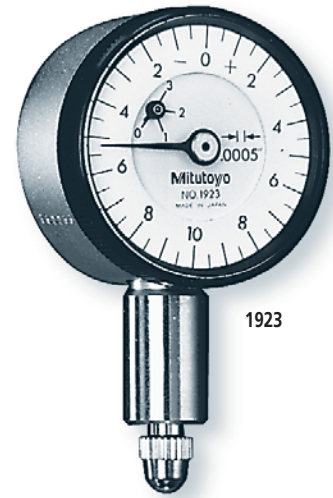

1923

SPECIFICATIONS

Inch				ANSI/AGD type					
Stem dia. 3/8", #4-48 UNF Thread									
Graduation	Range	Range/rev	Dial reading	Order No.		Accuracy		Measuring force	Jeweled bearing type
				w/ lug	Flat-back	First 2.5 Rev	Overall Accuracy		
.0001"	.01"	.004"	0-2-0	1927-10	1927B-10	±.0002"	±.0002"	1.4N or less	✓
.0001"	.025"	.01"	0-5-0	1925-10	1925B-10	±.0002"	±.0002"	1.4N or less	✓
.0005"	.05"	.02"	0-10-0	1923	1923B	±.0005"	±.0005"	1.4N or less	—
.001"	.1"	.04"	0-20-0	1921	1921B	±.001"	±.001"	1.4N or less	—

Metric				ISO/JIS type					
Stem ø 8mm, M2.5 x 0.45 Thread									
Graduation	Range	Range/Rev	Dial reading	Order No.		Accuracy		Measuring force	Jeweled bearing type
				w/ lug	Flat-back	First 2.5 Rev	Overall Accuracy		
0.002mm	0.5mm	0.2mm	0-100-0	1913-10	1913B-10	±0.011mm	±0.011mm	1.4N or less	✓
0.01mm	2.5mm	1mm	0-50-0	1911	1911B	±0.011mm	±0.011mm	1.4N or less	—

 Jeweled bearing type

DIMENSIONS

Inch Model		Unit: Inch		Metric Model		Unit: mm	
Order Number	A	B		Order Number	A	B	
1927-10	1.46"	.26"		1911	42	11.5	
1925-10	1.48"	.28"		1913-10	39.5	9	
1923	1.51"	.31"					
1921	1.58"	.37"					

Dial Indicators

SERIES 1

SPECIFICATIONS

Inch Stem dia. 3/8" #4-48 UNF Thread ANSI/AGD type

Graduation	Range	Range / Rev	Dial reading	Order No.		Accuracy		Measuring force	Shockproof	Jeweled bearing
				(W/Lug)	(Flat-back)	First 2.5 Rev	Overall Accuracy			
.0001"	.025"	.01"	0-10	1802S-10	1802SB-10	±.0001"	±.0001"	1.4N or less	✓	✓
.0001"	.025"	.01"	0-5-0	1803S-10	1803SB-10	±.0001"	±.0001"	1.4N or less	✓	✓
.0005"	.1"	.04"	0-40	1670S	1670SB	±.0005"	±.0005"	1.4N or less		
.0005"	.1"	.04"	0-20-0	1671S	1671SB	±.0005"	±.0005"	1.4N or less		
.0005"	.125"	.05"	0-50	1506S	1506SB	±.0005"	±.0005"	1.4N or less		
.0005"	.125"	.05"	0-25-0	1507S	1507SB	±.0005"	±.0005"	1.4N or less		
.001"	.125"	.05"	0-50	1780S	1780SB	±.001"	±.001"	1.4N or less		
.001"	.125"	.025"	0-25-0	1781S	1781SB	±.001"	±.001"	1.4N or less		
.001"	.25"	.1"	0-100	1410S	1410SB	±.001"	±.001"	1.4N or less		
.001"	.25"	.1"	0-100	1410S-10	1410SB-10	±.001"	±.001"	1.4N or less		✓
.001"	.25"	.1"	0-50-0	1411S	1411SB	±.001"	±.001"	1.4N or less		

Shockproof type Jeweled bearing type



1803S-10

Metric Metric - ANSI Standard Stem dia. 3/8" #4-48 UNF Thread yellow dial face ANSI/AGD type

Graduation	Range	Range / Rev	Dial reading	Order No.		Accuracy		Measuring force
				(W/Lug)	(Flat-back)	First 2.5 Rev	Overall Accuracy	
0.01mm	2.5mm	1mm	0-100	1230S-01	1230SB-01	±0.01mm	-	1.4N or less
0.01mm	2.5mm	1mm	0-50-0	1231S-01	1231SB-01	±0.01mm	-	1.4N or less
0.01mm	5mm	1mm	0-100	1044S-01	1044SB-01	±0.01mm	±0.013mm	1.4N or less
0.01mm	5mm	1mm	0-50-0	1045S-01	1045SB-01	±0.01mm	±0.013mm	1.4N or less



1411S

DIMENSIONS

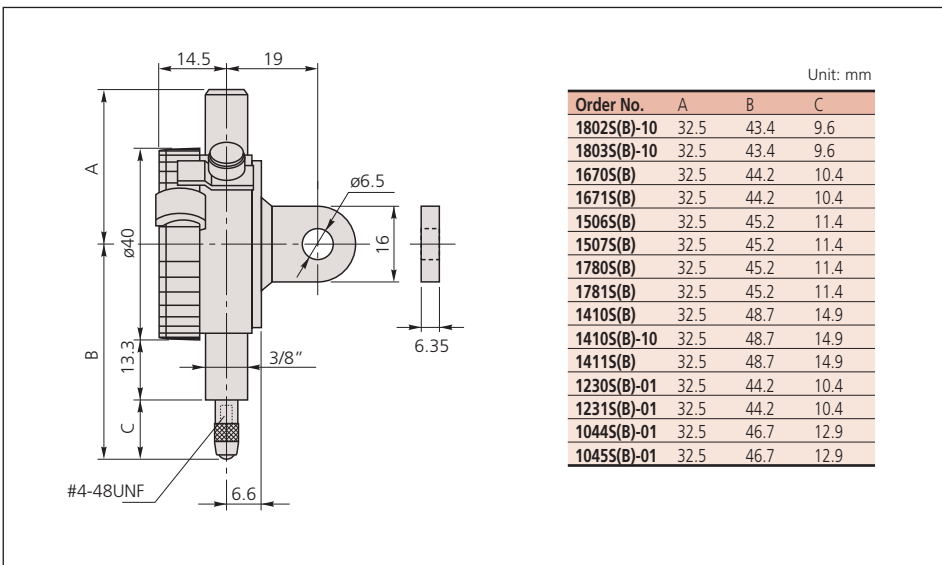

1506S

Dial Indicators

SERIES 1



1109S-10



1040S



1013S



1045S



1003



1044S

Metric Stem ϕ 8mm M2.5 X 0.45 Thread ISO/JIS type

Graduation	Range	Range / Rev	Dial reading	Order No.		Accuracy		Measuring force	Shockproof type	Waterproof type	Jeweled bearing type
				(W/Lug)	(Flat-back)	First 2.5 Rev	Overall Accuracy				
0.001mm	1mm	0.2mm	0-100-0	1109S-10	1109SB-10	± 0.001 mm	± 0.007 mm	1.5N or less	✓		✓
0.002mm	1mm	0.2mm	0-100-0	1013S-10	1013SB-10	± 0.002 mm	± 0.01 mm	1.5N or less	✓		✓
0.005mm	3.5mm	0.5mm	0-50	1124S	1124SB	± 0.005 mm	± 0.013 mm	1.4N or less			✓
0.01mm	3.5mm	0.5mm	0-50-0	1040S	1040SB	± 0.01 mm	± 0.013 mm	1.5N or less			
0.01mm	3.5mm	0.5mm	0-25-0	1041S	1041SB	± 0.01 mm	± 0.013 mm	1.5N or less			
0.01mm	4mm	1mm	0-50-0	1003	1003B	± 0.01 mm	± 0.013 mm	1.5N or less			
0.01mm	5mm	1mm	0-100	1044S	1044SB	± 0.01 mm	± 0.013 mm	1.5N or less			
0.01mm	5mm	1mm	0-100	1044S-60	1044SB-60	± 0.01 mm	± 0.013 mm	2N or less		✓	
0.01mm	5mm	1mm	0-100	1044S-10	1044SB-10	± 0.01 mm	± 0.013 mm	4N or less	✓		
0.01mm	5mm	1mm	0-50	1045S	1045SB	± 0.01 mm	± 0.013 mm	1.4N or less			



Shockproof type



Waterproof type



Jeweled bearing type

DIMENSIONS

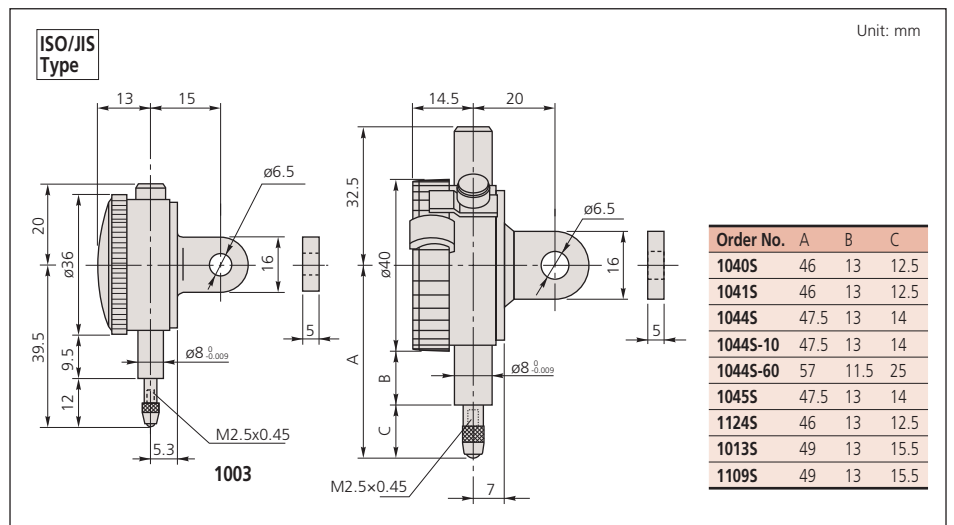

Dial Indicators

SERIES 1 — Compact One Revolution Type for Error-free Reading



One revolution type



1929S

Unlike many other dial indicators, the one-revolution dial indicator literally shows the entire spindle travel or range as one sweep of the hand, eliminating the possibility of reading errors due to miscounting the multiple revolutions. With one-revolution dial indicators, "within tolerance" and "out-of-tolerance" can never be misinterpreted. An unique shock-proof mechanism is incorporated, providing improved immunity to shock due to sudden spindle retraction caused by high impact.



Shockproof type



Dustproof type



Waterproof type



Jeweled bearing type

SPECIFICATIONS

Inch Stem dia. 3/8", #4-48 UNF Thread □ ANSI/AGD type

Graduation	Range (range/full stroke)	Dial reading	Order No.		Accuracy	Measuring force				
			w/lug	Flat-back						
.0001"	.006" / .0079"	3-0-3	1910S-72	1910SB-72	±.0001"	1.4N or less	✓	✓	—	—
.0005"	.04" / .055"	20-0-20	1909S-62	1909SB-62	±.0005"	1.4N or less	✓	✓	—	—

Metric Stem \varnothing 8mm, M2.5 x 0.45 Thread □ ISO/JIS type

Graduation	Range (range/full stroke)	Dial reading	Order No.		Accuracy	Measuring force				
			w/lug	Flat-back						
0.001mm	0.1mm / 0.14mm	50-0-50	1900S-10	1900SB-10	±0.005mm	1.5N or less	✓	—	—	✓
0.001mm	0.1mm / 0.14mm	50-0-50	1900S-70	1900SB-70	±0.006mm	1.5N or less	✓	—	✓	✓
0.001mm	0.1mm / 0.14mm	50-0-50	1900S-72	1900SB-72	±0.006mm	1.5N or less	✓	✓	—	✓
0.01mm	1mm / 1.4mm	50-0-50	1929S	1929SB	±0.011mm	1.4N or less	✓	—	—	—
0.01mm	1mm / 1.4mm	50-0-50	1929S-60	1929SB-60	±0.011mm	1.4N or less	✓	—	✓	—
0.01mm	1mm / 1.4mm	50-0-50	1929S-62	1929SB-62	±0.011mm	1.4N or less	✓	✓	—	—

DIMENSIONS

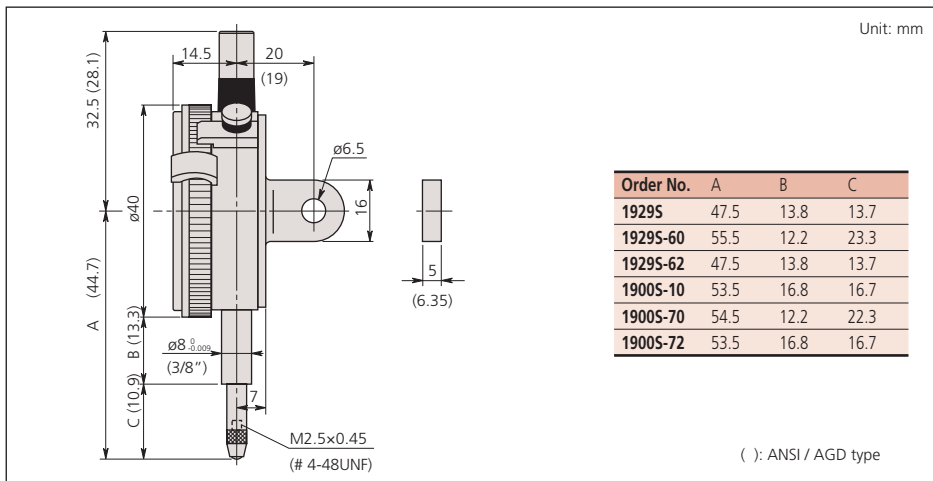

1929S
1929S-60
1929S-62



1900S-10
1900S-70
1900S-72

Optional Accessories

- : Backs (See page F-32.)
- : Contact points (See page F-33.)

Dial Indicators

SERIES 2 — Standard One Revolution Type for Error-free Reading



One revolution type.



Shockproof type



Waterproof type



Dustproof type



Jeweled bearing type



2900S-10



2929S
2929S-60
2929S-62



2959S



2900S-10
2900S-70
2900S-72



2901S-10

SPECIFICATIONS

Metric

Stem \varnothing 8mm, M2.5 x 0.45 Thread

ISO/JIS type

Graduation	Range (range/full stroke)	Dial reading	Order No.		Accuracy	Measuring force	Shockproof	Waterproof	Dustproof	Jeweled bearing
			w/ lug	Flat-back						
0.001mm	0.08mm / 0.1mm	40-0-40	2900S-10	2900SB-10	± 0.003 mm	1.4N or less	✓	—	—	✓
0.001mm	0.08mm / 0.1mm	40-0-40	2900S-70	2900SB-70	± 0.003 mm	2.0N or less	✓	✓	—	✓
0.001mm	0.08mm / 0.1mm	40-0-40	2900S-72	2900SB-72	± 0.003 mm	2.0N or less	✓	—	✓	✓
0.001mm	0.16mm / 0.2mm	80-0-80	2901S-10	2901SB-10	± 0.004 mm	1.4N or less	✓	—	—	✓
0.01mm	0.8mm / 1mm	40-0-40	2929S	2929SB	± 0.009 mm	2.0N or less	✓	—	—	—
0.01mm	0.8mm / 1mm	40-0-40	2929S-60	2929SB-60	± 0.009 mm	2.0N or less	✓	✓	—	—
0.01mm	0.8mm / 1mm	40-0-40	2929S-62	2929SB-62	± 0.009 mm	2.0N or less	✓	—	✓	—
0.01mm	1.6mm / 2mm	80-0-80	2959S	2959SB	± 0.013 mm	1.4N or less	✓	—	—	—
0.01mm	0.5mm / 0.7mm	25-0-25	—	2971*	± 0.010 mm	1.4N or less	✓	—	✓	—
0.01mm	1mm / 1.4mm	50-0-50	—	2972*	± 0.012 mm	1.4N or less	✓	—	✓	—
0.02mm	1.6mm / 2mm	80-0-80	—	2973*	± 0.016 mm	1.4N or less	✓	—	✓	—
0.1mm	4mm / 10mm	2-0-2	2928S	2928SB	± 0.040 mm	1.4N or less	✓	—	—	—

* Flat back type only. (Lug-on-center back is not available.)

DIMENSIONS

ISO/JIS Type

Unit: mm

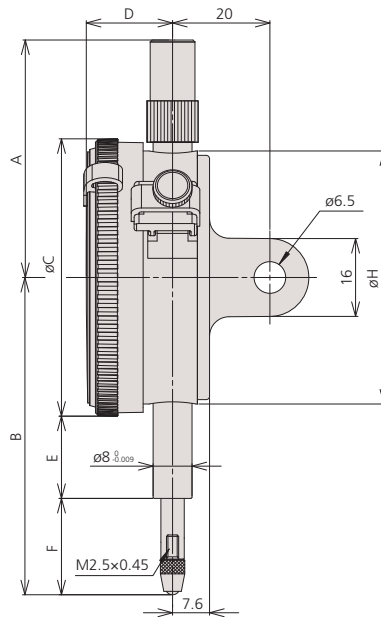

Order No.	A	B	C	D	E	F	H
2971	43.2	65.6	55.6	16.2	21	16.8	55
2972	43.2	66.0	55.6	16.2	21	17.2	55
2973	43.2	66.3	55.6	16.2	21	17.5	55
2929S	48.8	65.2	57	17.7	12.3	29.2	52
2929S-62	48.8	65.2	57	17.7	16.9	19.8	52
2929S-60	48.8	70	57	17.7	12.3	29.2	52
2959S	48.8	65.2	57	17.7	16.9	19.8	52
2900S-10	48.8	66	57	17.7	16.9	20.6	52
2900S-72	48.8	66	57	17.7	16.9	20.6	52
2900S-70	48.8	67	57	17.7	12.3	26.2	52
2901S-10	48.8	66.1	57	17.7	16.9	20.7	52
2928S	48.8	65.2	57	17.7	16.9	19.8	52

Optional Accessories

- : Backs (See page F-32.)
- : Contact points (See page F-33.)

Dial Indicators

SERIES 2 — Standard One Revolution Type for Error-free Reading

FEATURES

- An unique shock-proof mechanism is incorporated, providing improved immunity to shock due to sudden spindle retraction caused by high impact.
- The crystal is hard coated for durability and scratch resistance.
- Approximately 40% lighter than the conventional dial indicator.
- Provided with an improved resistance to shop floor contaminants such as water and dust.
- Due to the spindle bushing being offset from the stem, spindle movement will not be hindered or jammed when clamping along the stem.
- A pair of limit hands are provided for quick and easy tolerance judgment (GO/±NG).



One revolution type.

SPECIFICATIONS

Inch Stem 3/8" dia. , #4-48 UNF Thread

ANS/AGD type

Graduation	Range	Range/full stroke	Dial reading	Order No.		Accuracy	Measuring force			
				w/ lug	Flat-back					
.0001"	.008"	.01"	4-0-4	2910S-10	2910SB-10	±.0001"	1.8N or less	✓	✓	✓
.0001"	.008"	.01"	4-0-4	2910S-72	2910SB-72	±.0001"	2.5N or less	✓	✓	✓
.0005"	.04"	.05"	20-0-20	2909S-62	2909SB-62	±.0005"	2.5N or less	✓	✓	✓
.0005"	.02"	.028"	10-0-10	—	2976*	±.0005"	1.4N or less	✓	✓	✓
.0005"	.04"	.055"	20-0-20	—	2977*	±.0005"	1.4N or less	✓	✓	✓
.001"	.06"	.079"	30-0-30	—	2978*	±.001"	1.4N or less	✓	✓	✓

*Flat back type only. (Lug-on-center back is not available.)

Metric Stem 3/8" dia. , #4-48 UNF Thread Yellow Dial Face

ANS/AGD type

Graduation	Range	Range/full stroke	Dial reading	Order No.		Accuracy	Measuring force			
				w/ lug	Flat-back					
0.001mm	0.08mm	0.1mm	40-0-40	2900S-73	2900SB-73	±0.003mm	2.0N or less	✓	✓	✓

*Flat back type only. (Lug-on-center back is not available.)

DIMENSIONS

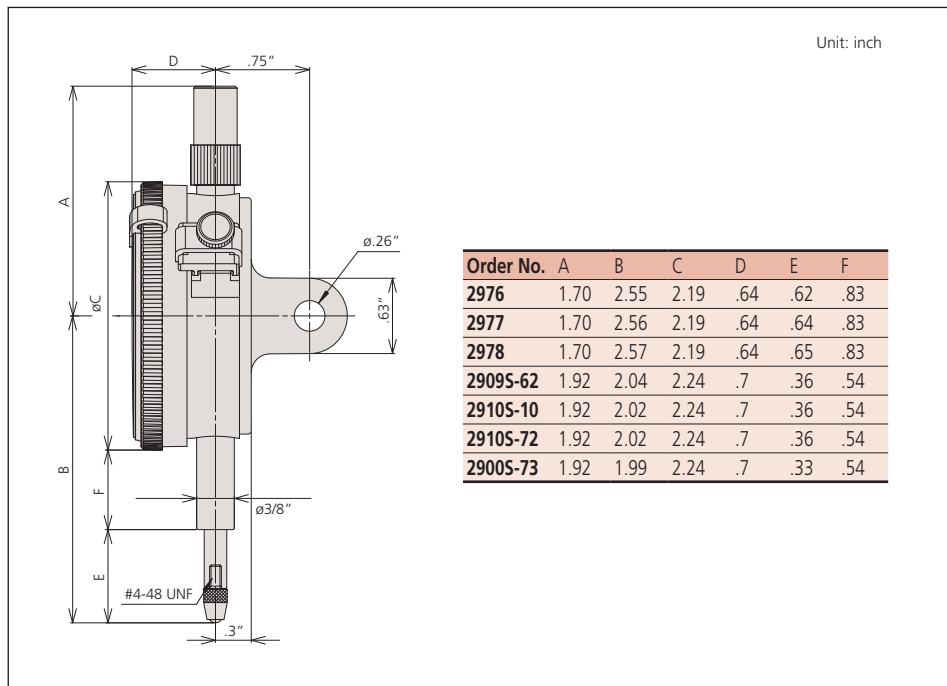

2909S-62



2978



Special Dial Indicators

SERIES 2



Adjustable hand

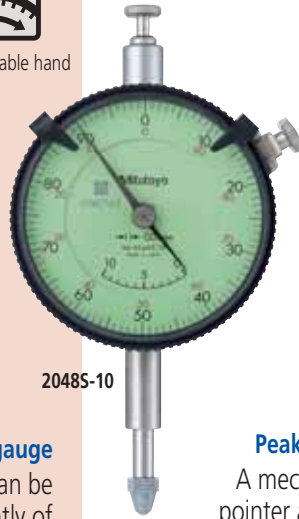

20485-10

Adjustable hand dial gauge

The hand position can be adjusted independently of the vertical movement of the spindle by rotating the top knob.



Peak hold



20465-80

Peak hold type dial gauge

A mechanism that stops the pointer and the spindle at the depressed position where the spindle is depressed makes the pointer stop and display the maximum value.



Double-face type



2940S

Double-face type dial gauge

The displacement of the spindle can be read from either the front or rear face.

SPECIFICATIONS

Inch		Stem dia. 3/8" #4-48 UNF Thread						ANSI/AGD type			
Graduation	Range	Range /rev	Dial reading	Order No.		Accuracy		Measuring force	Diamond	Adjustable hand	Peak hold
				w/lug	Flat-back	First 2.5 Rev	Overall Accuracy				
.001"	.5"	.1"	0-100	29155-10	29155B-10	±.001"	±.001"	1.8N or less	✓	✓	✓
.001"	.5"	.1"	0-50-0	29185-10	29185B-10	±.001"	±.001"	1.8N or less	✓	✓	✓

Metric		Stem dia. 3/8" #4-48 UNF Thread, Yellow Dial Face						ANSI/AGD type			
Graduation	Range	Range /rev	Dial reading	Order No.		Accuracy		Measuring force	Diamond	Adjustable hand	Peak hold
				w/lug	Flat-back	First 2.5 Rev	Overall				
0.01mm	10mm	1mm	0-100	20485-11	20485B-11	±13µm	±0.013mm	1.4N or less	✓	✓	✓

Metric		Stem ø 8mm, M2.5 x 0.45 Thread						ISO/JIS type				
Graduation	Range	Range /rev	Dial reading	Order No.		Accuracy	Measuring force	Diamond	Adjustable hand	Peak hold	STOP	Double-face
				w/lug	Flat-back							
0.01mm	10mm	1mm	0-100	20485-10	20485B-10	±0.015mm	1.4N or less	✓	✓	✓	✓	
0.01mm	10mm	1mm	0-100	20465-80	20465B-80	±0.015mm	5.0N or less				✓	
0.01mm	10mm	1mm	0-100	2940S	—	±0.015mm	3.0N or less					✓

DIMENSIONS

Order No.	A	B	C
29155-10, 29185-10	52.2	64.1	22
20485-11	47.7	59.5	17.4

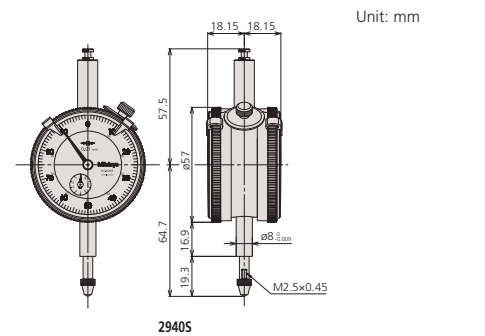
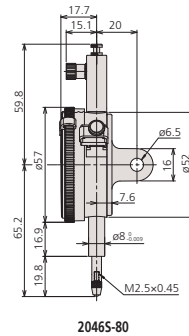
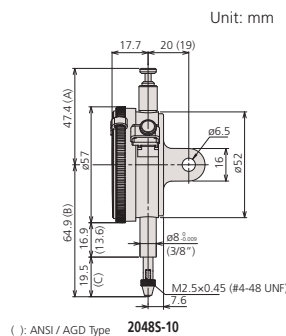



Dial Indicators

SERIES 2 — Standard Type, Inch Reading

SPECIFICATIONS

Inch Stem 3/8" dia. ø8mm #4-48 UNF Thread ANSI/AGD type

Graduation	Range	Range /Rev	Dial Reading	Order No.		Accuracy		Measuring force			
				w/lug	Flat-back	First 2.5 Rev	Overall				
.0001"	.025"	.01"	0-10	2802S-10	2802SB-10	±.0001"	±.0001"	2.5N or less	✓		✓
.0001"	.025"	.01"	0-5-0	2803S-10	2803SB-10	±.0001"	±.0001"	2.5N or less	✓		✓
.0001"	.05"	.01"	0-10	2804S-10	2804SB-10	±.0001"	±.0002"	2.0N or less	✓		✓
.0001"	.05"	.01"	0-5-0	2805S-10	2805SB-10	±.0001"	±.0002"	2.0N or less	✓		✓
.0001"	.05"	.01"	10-0	2905S-10	2905SB-10	±.0001"	±.0002"	2.0N or less	✓	✓	✓
.0001"	.05"	.01"	0-5-0	2923S-10	2923SB-10	±.0001"	±.0002"	2.0N or less	✓		✓
.0001"	.25"	.01"	0-10	2356S-10	2356SB-10	±.0001"	±.0005"	2.0N or less			✓
.0001"	.5"	.01"	0-10	2358S-10	2358SB-10	±.0001"	±.0008"	2.0N or less			✓
.0005"	.125"	.05"	0-50	2506S	2506SB	±.0005"	±.0005"	1.8N or less			
.0005"	.125"	.05"	0-25-0	2507S	2507SB	±.0005"	±.0005"	1.8N or less			
.0005"	.125"	.05"	0-25-0	2922S	2922SB	±.0005"	±.0005"	1.8N or less			
.0005"	.4"	.04"	0-20-0	2675S	2675SB	±.0005"	±.0015"	1.8N or less			
.0005"	.5"	.05"	0-50	2514S	2514SB	±.0005"	±.0015"	1.8N or less			
.0005"	1"	.05"	0-50	2776S	2776SB	±.0005"	±.002"	1.8N or less			
.001"	.5"	.1"	0-100	2414S	2414SB	±.001"	±.001"	1.8N or less			
.001"	.5"	.1"	0-50-0	2415S	2415SB	±.001"	±.001"	1.8N or less			
.001"	1"	.1"	0-100	2416S	2416SB	±.001"	±.002"	1.8N or less			
.001"	1"	.1"	0-100	2416S-06*	2416SB-06*	±.001"	±.002"	1.8N or less			
.001"	1"	.1"	0-100	2416S-10	2416SB-10	±.001"	±.002"	1.8N or less			✓
.001"	1"	.1"	0-50-0	2417S	2417SB	±.001"	±.002"	1.8N or less			
.001"	1"	.1"	100-0	2904S	2904SB	±.001"	±.002"	1.8N or less		✓	
.001"	2"	1"	0-100	2424S-19	2424SB-19	±.001"	±.003"	2.5N or less	✓		✓

* Black Face



Shockproof type



Reverse reading type



Jeweled bearing type



2416S



2803S-10

Optional Accessories

- : Backs (See page F-32.)
- : Contact points (See page F-33.)

Dial Indicators

SERIES 2 — Standard Type, Inch Reading

DIMENSIONS

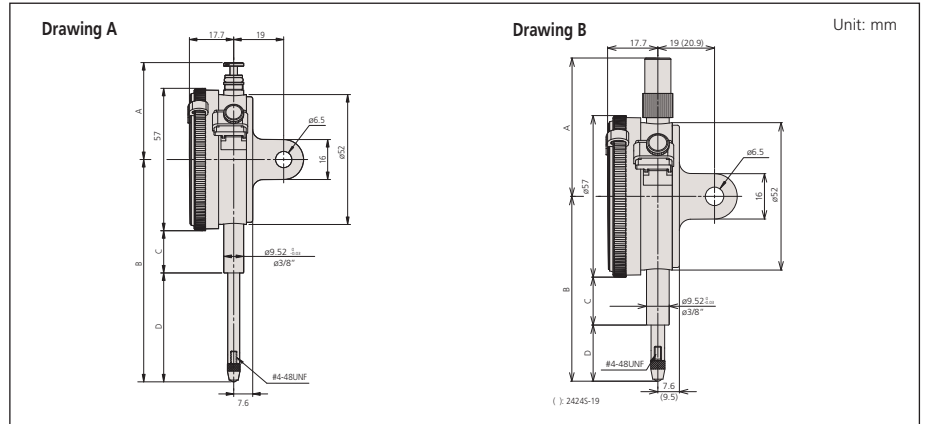

24245-19



2506S



29235-10

2 Group Inch

Order No.	A	B	C	D	Drawing
2356S(B)-10	48.8	57.2	13.6	15.1	B
2358S(B)-10	38.9	63.6	13.6	21.5	A
2414S(B)	38.9	64.1	13.6	22	A
2415S(B)	38.9	64.1	13.6	22	A
2416S(B)	38.9	76.8	13.6	34.7	A
2416S(B)-06	38.9	76.8	13.6	34.7	A
2416S(B)-10	38.9	76.8	13.6	34.7	A
2417S(B)	38.9	76.8	13.6	34.7	A
2424S(B)-19	118.5	142.5	54.3	59.7	B
2506S(B)	48.8	54.3	13.6	12.2	B
2507S(B)	48.8	54.3	13.6	12.2	B
2514S(B)	38.9	64.1	13.6	22	A

Order No.	A	B	C	D	Drawing
2576S(B)-70	48.8	63.5	10.6	24.4	B
2675S(B)	48.8	61.2	13.6	19.1	B
2776S(B)	38.9	76.8	13.6	34.7	A
2802S(B)-10	48.8	51.4	13.6	9.3	B
2803S(B)-10	48.8	51.4	13.6	9.3	B
2804S(B)-10	48.8	51.7	13.6	9.6	B
2805S(B)-10	48.8	51.7	13.6	9.6	B
2904S(B)	38.9	76.8	13.6	34.7	A
2905S(B)-10	48.8	51.7	13.6	9.6	B
2914S(B)	38.9	64.1	13.6	22	A
2915S(B)-10	52.2	63.3	13.6	21.2	A
2918S(B)-10	52.2	63.3	13.6	21.2	A
2922S(B)	48.8	54.3	13.6	12.2	B
2923S(B)-10	48.8	51.7	13.6	9.6	B

Dial Indicators

SERIES 2 — Metric Standard Type

Series 2 dial indicators are Mitutoyo's most popular, and have the widest application.

FEATURES

- Standard 0.01mm graduation dial gauges having an outer frame with an outside diameter of 57mm. All types come with limit pins and an outer frame clamp as standard.
- The outer clamp and lifting lever (optional) can be attached to either the right or left side. These parts can be easily installed and removed without tools.
- Secured adhesion between the outer frame and crystal as well as the use of an O-ring ensure countermeasures against water and oil permeation via the front face.
- The stem spindle is made of high-strength quench-hardened stainless steel which resists strenuous use.
- A carbide contact point is used.
- The grand gear uses stainless steel that is resistant to wear and deformation.
- Application of a hard coating on the surface of the crystal makes the gauge highly scratch- and chemical-resistant.

-  Shockproof type
-  Waterproof type
-  Long stem type
-  Jeweled bearing type
-  Double scale spacing type
-  w/ coaxial revolution counter
-  Reverse reading type
-  w/ damper at lowest rest point



SPECIFICATIONS

Metric Stem dia. ø8mm M2.5 x 0.45 Thread

ISO/JIS type

Graduation	Range	Range / Rev	Dial reading	Order No.		Accuracy	Measuring force	Features									
				w/ lug	Flat-back			Shockproof	Waterproof	Long stem	Jeweled bearing	Double scale	Coaxial counter	Reverse reading	Damper		
0.001mm	1mm	(0.1mm)	0-100	2110S-10	2110SB-10	±0.005mm	1.5N or less	✓				✓	✓				
0.001mm	1mm	(0.1mm)	0-100	2110S-70	2110SB-70	±0.005mm	2.0N or less		✓			✓	✓				
0.001mm	1mm	(0.2mm)	0-100-0	2109S-10	2109SB-10	±0.005mm	1.5N or less	✓				✓	✓				
0.001mm	1mm	(0.2mm)	0-100-0	2109SH-10	2109SHB-10	±0.003mm	1.5N or less	✓				✓	✓				
0.001mm	1mm	(0.2mm)	0-100-0	—	2109SLB-10	±0.005mm	1.5N or less	✓		✓		✓	✓				
0.001mm	1mm	(0.2mm)	0-100-0	2109S-70	2109SB-70	±0.005mm	2.0N or less	✓	✓			✓	✓				
0.001mm	2mm	(0.2mm)	0-100-0	2113S-10	2113SB-10	±0.007mm	1.5N or less	✓				✓	✓				
0.001mm	5mm	(0.2mm)	0-100-100	2118S-10	2118SB-10	±0.010mm	1.5N or less					✓	✓				
0.001mm	5mm	(0.2mm)	0-100-0	2119S-10	2119SB-10	±0.010mm	1.5N or less					✓	✓				
0.005mm	5mm	(0.5mm)	0-50	2124S-10	2124SB-10	±0.012mm	1.5N or less					✓	✓				
0.01mm	5mm	(1mm)	0-100	2044S	2044SB	±0.012mm	1.4N or less										
0.01mm	5mm	(1mm)	0-100	2044S-09	2044SB-09	±0.013mm	1.4N or less	✓									
0.01mm	5mm	(1mm)	0-100	2044S-60	2044SB-60	±0.012mm	2.5N or less		✓								
0.01mm	5mm	(1mm)	0-50-0	2045S	2045SB	±0.012mm	1.4N or less									✓	
0.01mm	10mm	(1mm)	0-100	2046S	2046SB	±0.013mm	1.4N or less										
0.01mm	10mm	(1mm)	0-100	2046SY	2046SYB	±0.013mm	1.4N or less										
0.01mm	10mm	(1mm)	0-100	2046SH	2046SHB	±0.08mm	1.4N or less										
0.01mm	10mm	(1mm)	0-100	—	2046SLB	±0.013mm	1.4N or less					✓					
0.01mm	10mm	(1mm)	0-100	2046S-09	2046SB-09	±0.015mm	1.4N or less	✓									
0.01mm	10mm	(1mm)	0-100	2046S-60	2046SB-60	±0.013mm	2.5N or less		✓								
0.01mm	10mm	(1mm)	0-100	2046S-69	2046SB-69	±0.015mm	2.5N or less	✓	✓								
0.01mm	10mm	(1mm)	0-100	2046S-15	2046SB-15	±0.013mm	0.8N or less*					✓					
0.01mm	10mm	(1mm)	0-100	2310S-10	2310SB-10	±0.015mm	1.4N or less					✓		✓			
0.01mm	10mm	(1mm)	100-0	2902S	2902SB	±0.013mm	1.4N or less									✓	
0.01mm	10mm	(1mm)	0-50-0	2047S	2047SB	±0.013mm	1.4N or less										
0.01mm	20mm	(1mm)	0-100	2050S	2050SB	±0.020mm	2.0N or less										✓
0.01mm	20mm	(1mm)	0-100	2050S-60	2050SB-60	±0.020mm	2.5N or less		✓								
0.01mm	20mm	(1mm)	0-100	2050S-19	2050SB-19	±0.020mm	2.0N or less	✓				✓					✓
0.01mm	20mm	(1mm)	0-100	2320S-10	2320SB-10	±0.020mm	2.0N or less					✓		✓			✓
0.01mm	30mm	(1mm)	0-100	2052S	2052SB	±0.025mm	2.5N or less										✓
0.01mm	30mm	(1mm)	0-100	2052S-19	2052SB-19	±0.025mm	2.5N or less	✓				✓					✓
0.01mm	30mm	(1mm)	0-100	2330S-10	2330SB-10	±0.025mm	2.5N or less					✓		✓			✓
0.01mm	30mm	(1mm)	100-0	2952S	2952SB	±0.025mm	2.5N or less									✓	✓

*Use in a vertical position only (contact point downward).

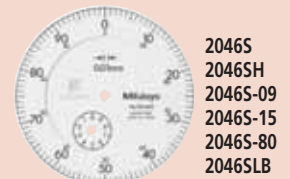



Dial Indicators

SERIES 2 — Metric Standard Type

DIMENSIONS

Unit: mm



2902S



2310S-10



2044S
2044S-60
2044S-09



2045S

Optional Accessories

- : Backs (See page F-32.)
- : Contact points (See page F-33.)

ISO/JIS
Type

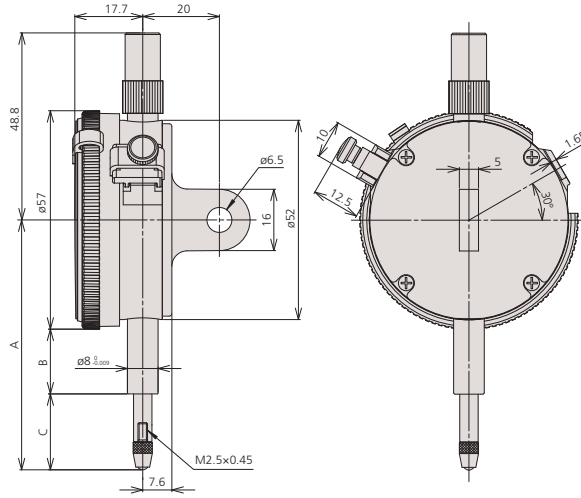

Order No.	A	B	C
2124S-10	60.3	16.9	14.9
2110S-10	66.5	16.9	21.1
2110S-70	67.5	12.3	26.7
2109S-10	60.5	16.9	15.1
2109SH-10	60.5	16.9	15.1
2109SLB-10	80.5	36.9	15.1
2109S-70	65.3	12.3	24.5
2113S-10	61	16.9	15.6
2118S-10	60.3	16.9	14.9
2119S-10	60.3	16.9	14.9
2044S	65.2	16.9	19.8
2044S-09	65.2	16.9	19.8
2044S-60	70	12.3	29.2
2045S	65.2	16.9	19.8
2046S	65.2	16.9	19.8
2046SH	65.2	16.9	19.8
2046SLB	85.2	36.9	19.8
2046S-09	65.2	16.9	19.8
2046S-60	70	12.3	29.2
2046S-69	70	12.3	29.2
2046S-15	65.2	16.9	19.8
2310S-10	65.2	16.9	19.8
2902S	65.2	16.9	19.8
2047S	65.2	16.9	19.8

ISO/JIS
Type

Unit: mm

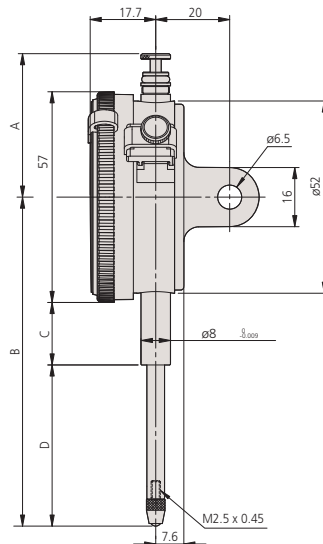

Order No.	A	B	C	D
2050S	38.8	75.2	16.9	29.8
2050S-60	59.8	87.2	12.3	46.4
2050S-19	38.8	75.2	16.9	29.8
2320S-10	38.8	75.2	16.9	29.8
2052S	38.8	88.7	16.9	43.3
2052S-19	38.8	88.7	16.9	43.3
2330S-10	38.8	88.7	16.9	43.3
2952S	38.8	88.7	16.9	43.3

Dial Indicators

SERIES 2 — ANSI / AGD Type Metric Dial Indicator

SPECIFICATIONS

Graduation	Range	Range / Rev	Dial reading	Order No.		Accuracy		Measuring force				
				w/ lug	Flat-back	First 2.5 Rev	Overall					
0.001mm	1mm	0.2mm	0-10-0	2109S-11	2109SB-11	±0.003mm	±0.004mm	1.5N or less	✓	✓		
0.001mm	5mm	0.2mm	0-10-0	2119S-11	2119SB-11	±0.007mm	±0.01mm	1.5N or less	✓			
0.01mm	2.5mm	1mm	0-100	2230S-01	2230SB-01	±0.01mm	±0.01mm	1.4N or less				
0.01mm	2.5mm	1mm	0-50-0	2231S-01	2231SB-01	±0.01mm	±0.01mm	1.4N or less				
0.01mm	5mm	1mm	0-100	2044S-01	2044SB-01	±0.01mm	±0.01mm	1.4N or less				
0.01mm	10mm	1mm	0-100	2046S-01	2046SB-01	±0.01mm	±0.013mm	1.4N or less				
0.01mm	10mm	1mm	0-100	2046S-11	2046SB-11	±0.01mm	±0.013mm	1.4N or less	✓			
0.01mm	10mm	1mm	0-50-0	2047S-01	2047SB-01	±0.01mm	±0.013mm	1.4N or less				
0.01mm	10mm	1mm	0-50-0	2047S-11	2047SB-11	±0.01mm	±0.013mm	1.4N or less	✓			
0.01mm	10mm	1mm	100-0	2902S-01	2902SB-01	±0.01mm	±0.013mm	1.4N or less				
0.01mm	20mm	1mm	0-100	2050S-01	2050SB-01	±0.01mm	±0.02mm	2.0N or less				
0.01mm	20mm	1mm	0-100	2050S-11	2050SB-11	±0.01mm	±0.02mm	2.0N or less	✓			
0.01mm	25mm	1mm	0-100	2056S-01	2056SB-01	±0.01mm	±0.025mm	2.5N or less				

DIMENSIONS

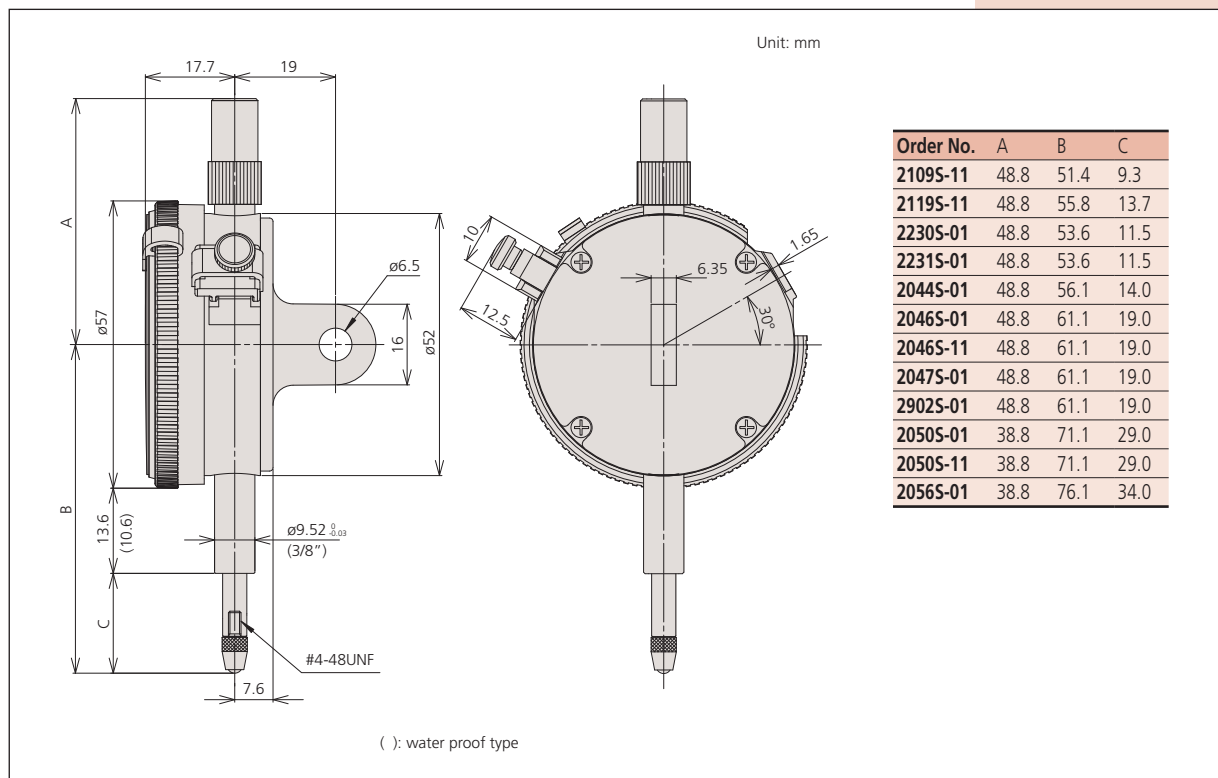



Dial Indicators

SERIES 3 — Large Dial Face and Long Stroke Type

- Dial gages with a large-diameter (78mm / 3.07") graduation face to ease reading.
- All types come with limit pins and an outer frame clamp as standard.



3046S



3047S



3050S



3052S-19



3109S-10



3416S



3058S-19

DIMENSIONS

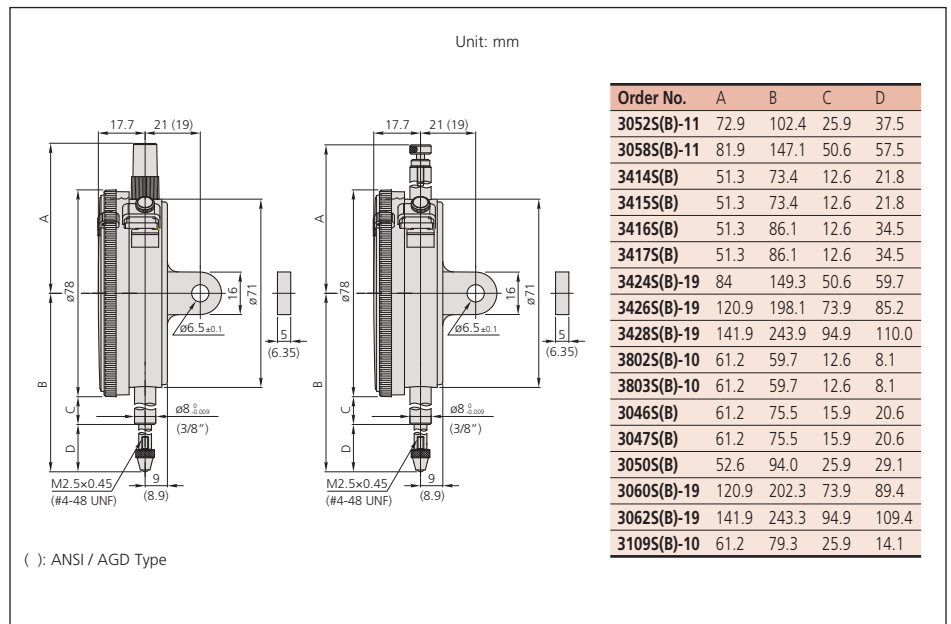



Dial Indicators



SERIES 3 — Large Dial Face

SPECIFICATIONS





Inch Stem 3/8" DIA. #4-48 UNF Thread ANSI/AGD type

Graduation	Range	Range /rev	Dial reading	Order No.		Accuracy		Measuring force			
				W/ lug	Flat-back	First 2.5 Rev	Overall accuracy				
.0001"	.025"	.01"	0-10	3802S-10	3802SB-10	±.0001"	±.0001"	2.0N or less	✓	✓	
.0001"	.025"	.01"	0-5-0	3803S-10	3803SB-10	±.0001"	±.0001"	2.0N or less	✓	✓	
.001"	.5"	.1"	±0-100	3414S	3414SB	±.001"	±.001"	1.8N or less			
.001"	.5"	.1"	0-50-0	3415S	3415SB	±.001"	±.001"	1.8N or less			
.001"	1"	.1"	±0-100	3416S	3416SB	±.001"	±.002"	1.8N or less			
.001"	1"	.1"	0-50-0	3417S	3417SB	±.001"	±.002"	1.8N or less			
.001"	2"	.1"	±0-100	3424S-19	3424SB-19	±.001"	±.003"	3.0N or less	✓	✓	✓
.001"	3"	.1"	±0-100	3426S-19	3426SB-19	±.001"	±.005"	3.0N or less	✓	✓	✓
.001"	4"	.1"	±0-100	3428S-19	3428SB-19	±.001"	±.005"	3.2N or less	✓	✓	✓

Metric Stem 3/8" DIA. #4-48 UNF Thread, Yellow dial face ANSI/AGD type

Graduation	Range	Range /rev	Dial reading	Order No.		Accuracy		Measuring Force			
				W/ lug	Flat-back	First 2.5 Rev	Overall accuracy				
0.01mm	30mm	1mm	±0-100	3052S-11	3052SB-11	±0.01mm	±0.03mm	2.5N or less	✓	✓	✓
0.01mm	50mm	1mm	±0-100	3058S-11	3058SB-11	±0.01mm	±0.04mm	3.0N or less	✓	✓	✓

Metric Stem ø 8mm M2.5x0.45 Thread ISO/JIS type

Graduation	Range	Range /rev	Dial reading	Order No.		Accuracy	Measuring Force				
				W/ lug	Flat-back						
0.001mm	1mm	0.2mm	0-10-0	3109S-10	3109SB-10	±0.004mm	1.5N or less	✓	✓		
0.01mm	10mm	1mm	0-100	3046S	3046SB	±0.015mm	1.4N or less				
0.01mm	10mm	1mm	0-50-0	3047S	3047SB	±0.015mm	1.4N or less				
0.01mm	20mm	1mm	0-100	3050S	3050SB	±0.020mm	2.0N or less				✓
0.01mm	30mm	1mm	0-100	3052S-19	3052SB-19	±0.025mm	2.5N or less	✓	✓	✓	
0.01mm	50mm	1mm	0-100	3058S-19	3058SB-19	±0.035mm	3.0N or less	✓	✓	✓	
0.01mm	80mm	1mm	0-100	3060S-19*	3060SB-19*	±0.045mm	3.0N or less	✓	✓	✓	
0.01mm	100mm	1mm	0-100	3062S-19*	3062SB-19*	±0.050mm	3.2N or less	✓	✓	✓	

*use in a vertical position only



Shockproof type



w/ coaxial revolution counter



w/ damper at lowest rest point



Jeweled bearing type

Dial Indicators

SERIES 4 — Large Dial Face

- Dial gauges with a large-diameter (92mm / 3.62") graduation face to ease reading.
- All types come with limit pins and an outer frame clamp as standard.



4887S-19



4046S

Inch						Stem 3/8" DIA. #4-48 UNF Thread		ANSI/AGD type		
Graduation	Range	Range /rev	Dial reading	Order No.		Accuracy		Measuring Force		
				W/ lug	Flat-back	First 2.5 Rev	Overall accuracy			
.001"	3"	.1"	±0-100	4887S-19	4887SB-19	±.001"	±.005"	3.0N or less		

Metric						Stem ø 8mm M2.5x0.45 Thread		ISO/JIS type		
Graduation	Range	Range /rev	Dial reading	Order No.		Accuracy		Measuring force		
				W/ lug	Flat-back	First 2.5 Rev	Overall accuracy			
0.01mm	10mm	1mm	0-100	4046S	4046SB	± 0.01mm	± 0.015mm	1.4N or less		

DIMENSIONS

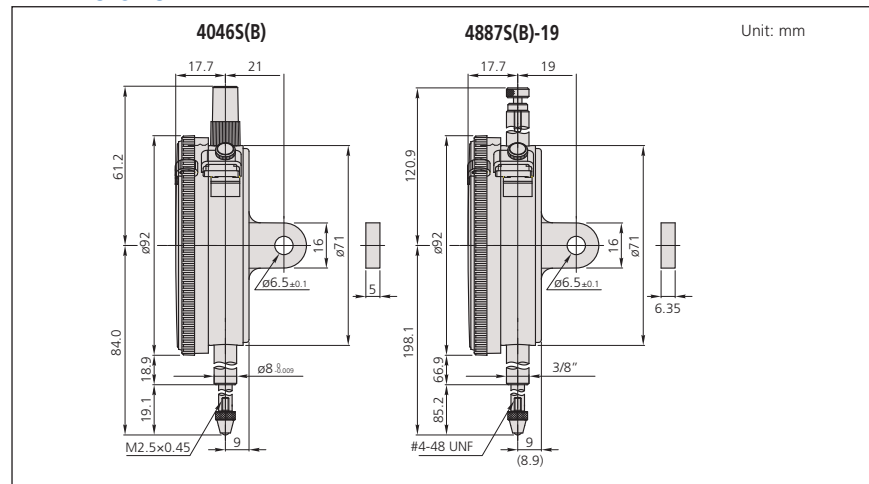

Back Plunger Type Dial Indicators

SERIES 1 and 2



Mitutoyo's back plunger type dial indicators are built with the measuring spindles on the back of the units. This type of indicator offers the same precision and durability as all other Mitutoyo dial indicators, and operates very effectively with optional holding bars.

- Back plunger type dial gauges are suitable for mounting onto leveling machine tool tables or inspection jigs, and for use in small spaces where the graduations of standard dial gauges are difficult to see.
- Model No. 1960, which uses Mitutoyo's proprietary shock-proofing mechanism, has excellent durability and shock resistance.



One revolution type



Shockproof type



Jeweled bearing type

SPECIFICATIONS

Inch Series 1 Stem 3/8" dia., #4-48 UNF Thread ANSI/AGD type

Graduation	Range	Range / Rev	Dial reading	Order No.	Accuracy	Measuring force			
.001"	.04"	.05"*	20-0-20	1961	±.001"	1.4N or less	✓	✓	
.001"	.2"	.05"	0-50	1166	±.001"	1.4N or less			
.001"	.2"	.05"	0-25-0	1167	±.001"	1.4N or less			
.001"	.2"	.05"	50-0	1168	±.001"	1.4N or less			✓

*Full stroke

Metric Series 1 Stem ø8mm, M2.5x0.45 Thread ISO/JIS type

Graduation	Range	Range / Rev	Dial reading	Order No.	Accuracy	Measuring force				Remarks
0.01mm	1mm	1.27mm*	50-0-50	1960	±0.014mm	1.4N or less	✓	✓		—
0.01mm	5mm	1mm	0-100	1160	±0.016mm	1.4N or less				—
0.01mm	5mm	1mm	100-0	1162	±0.016mm	1.4N or less			✓	—
0.01mm	5mm	1mm	0-100	1180-6	±0.016mm	1.5N or less				with arm (ø6x42mm)
0.01mm	5mm	1mm	0-100	1180-7	±0.016mm	1.5N or less				with arm (ø6.35x42mm)
0.01mm	5mm	1mm	0-100	1180-8	±0.016mm	1.5N or less				with arm (ø8x42mm)

Inch Series 2 Stem 3/8" dia., #4-48 UNF Thread ANSI/AGD type

Graduation	Range	Range/full stroke	Dial reading	Order No.	Accuracy	Measuring force			
.0001"	.008"	.01"	4-0-4	2991	±.0002"	1.5N or less	✓	✓	✓
.0005"	.04"	.05"	20-0-20	2961	±.0005"	1.8N or less	✓	✓	

Metric Series 2 Stem ø8mm, M2.5x0.45 Thread ISO/JIS type

Graduation	Range	Range/full stroke	Dial reading	Order No.	Accuracy	Measuring force			
0.001mm	0.1mm	0.14mm	50-0-50	2990	±0.0065mm	1.5N or less	✓	✓	✓
0.01mm	1mm	1.27mm	50-0-50	2960F	±0.014mm	1.4N or less	✓	✓	

Optional Accessories

- 136567:** Holding bar (ø6mm, L=81mm)
21AAA166: Holding bar (ø6mm, L=42mm) (Standard with 1180-6)
136568: Holding bar (ø8mm, L=81mm)
21AAA168: Holding bar (ø8mm, L=42mm) (Standard with 1180-8)
124625: Holding bar (.25" DIA, L=3.19")
21AAA167: Holding bar (.25" DIA, L=1.65") (Standard with 1180-7)

—: Backs (See page F-32.)

—: Contact points (See page F-33.)

Back Plunger Type Dial Indicators

SERIES 1 and 2



DIMENSIONS

Order No.	A	B	C
1160	25.0	13.8	43.3
1162	25.0	13.8	43.3
1166	25.0	13.0	42.5
1167	25.0	13.0	42.5
1168	25.0	13.0	42.5
1960	28.7	12.8	46.0
1961	25.0	10.9	40.4

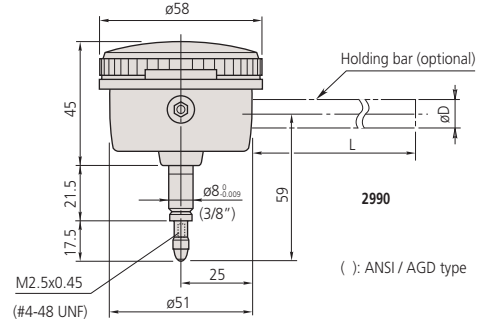
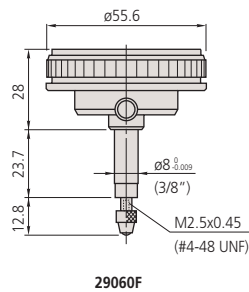
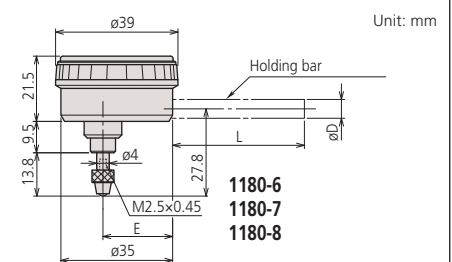
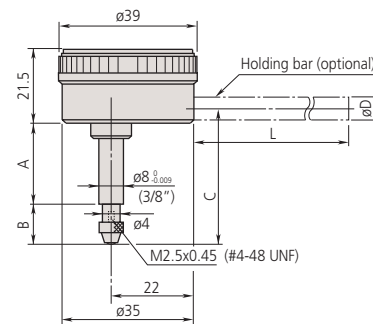











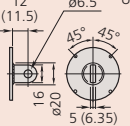

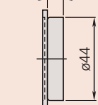

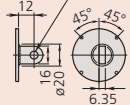
() : ANSI / AGD type

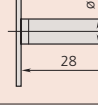
Backs

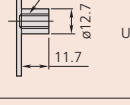
Optional Accessory for Digimatic and Dial Indicators

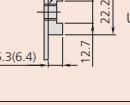
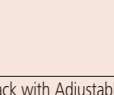
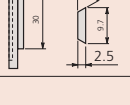
SPECIFICATIONS

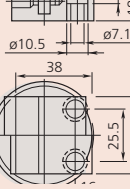
Description		Order No.			
		Series 0 (ϕ 31mm) 1003 (ϕ 36mm)	Series 1 (ϕ 41mm)	Series 2 (ϕ 57mm)	Series 3, 4 (ϕ 77, 91mm)
Flat Back 	 Unit: mm	191559: a=1.0 137906: for 1003 a=1.0	101211: a=2.2 136872: for water-proof type 191559: for 1911, 1913-10	101039: a=2.5 21AZB231: for water-proof of S type	100836: a=3.0
Lug-on-Center Back 	 Unit: mm	190561: Metric type 190139: Inch type 137905: for 1003	101210: metric type 101307: inch type 190561: for 1911, 1913-10	101040: metric type 101306: inch type 21AZB230: for water-proof of S type	100691: metric type 100797: inch type
Magnetic Back 	 Unit: mm	—	Special order	900928	900929
Back with Offset Lug 	 Unit: mm	—	Special order	101167	100837
Back with Post 	 Unit: mm	—	193172	101169	100839
Back with Screw Mount 	 Unit: mm	—	193173: M6x1, 193174: #1/4-28UNF,	136023: M6x1 101170: #1/4-28UNF	136024: M6x1 100840: #1/4-28UNF
Adjustable Back 	 Unit: mm	—	136025: M6x1 129721: #1/4-28UNF	136026: M6x1 101168: 1/4-28UNF	136027: M6x1 100838: #1/4-28UNF
Back with Dovetail 	 Unit: mm	—	—	900008	Special order
Back with Adjustable Bracket 	 Unit: mm	—	—	901963: Set No. 129902: Dovetail Rack Back 901964: Dovetail bracket for rack back	—

() : ANSI / AGD Type

There are two ways to support Digimatic and dial indicators; by either holding the stem or the lug on the back of the indicator. The back of the indicator may need to be replaced for special applications. A wide variety of backs are available for Mitutoyo Digimatic and dial indicators.

Application

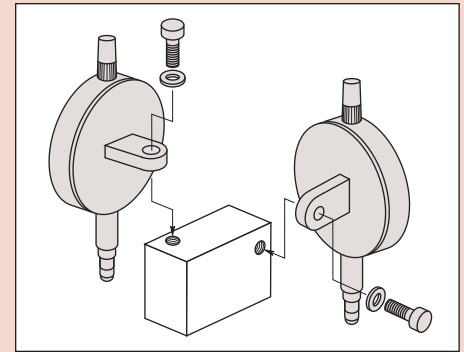

Contact Points

Optional Accessories for Digimatic and Dial Indicators and Linear Gages

ø.118" (ø3mm) Ball Point

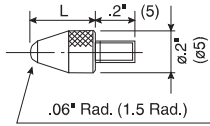

4-48UNF

L	Carbide	Sapphire	Ruby	Plastic
.28"	—	—	—	902018
.3"	131262	131263	131264	—
.6"	131265	131266	131267	—
1"	131268	131269	131270	—

M2.5 x 0.45mm

L	Carbide	Sapphire	Ruby	Plastic
7.3mm	901312*	—	—	901994
8mm	120045	120046	120047	—
15mm	120049	120050	120051	—
25mm	120053	120054	120055	—

*Furnished with standard metric dial indicators.

Shell type point

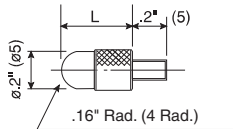

4-48UNF

L	Order No.
3/32" (.094")	193697
5/32" (.156")	101184
1/4" (.25")	21AAA031*
3/8" (.375")	21AAA032
1/2" (.5")	101185
5/8" (.625")	21AAA033
3/4" (.75")	101186
7/8" (.875")	21AAA034
1"	101187
1 1/4" (1.25")	21AAA035
1 1/2" (1.5")	21AAA036
1 3/4" (1.75")	21AAA037
2"	21AAA038
2 1/4" (2.25")	21AAA039
2 1/2" (2.5")	21AAA040
2 3/4" (2.75")	21AAA041
3"	21AAA042

M2.5 x 0.45mm

L	Order No.
5mm	101386
10mm	101118
15mm	137393
20mm	101387
25mm	101388

ø.16 Ball Point

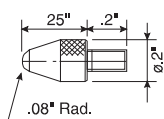

4-48UNF

Order No.
900032

ø1.8mm Ball Point

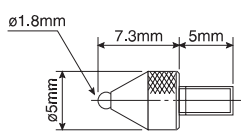

M2.5 x 0.45mm

Order No.
101122

Needle point

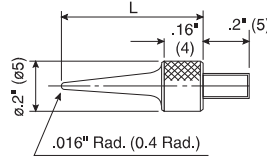

4-48UNF

L	Order No.
.6"	21AAA030
1"	21AAA046
1 1/2"	21AAA047
2"	21AAA048

M2.5 x 0.45mm

L	Order No.
15mm	101121
17mm	137413

Flat Point

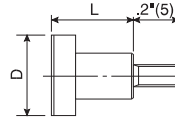

4-48UNF

D	L	Order No.
Ø1/2"	3/8"	101188
Ø3/8"	3/8"	101189

M2.5 x 0.45mm

D	L	Order No.
Ø10mm	10mm	101117

Flat Point, Carbide Tip

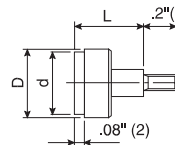

4-48UNF

D	d	L	Order No.
Ø.2"	Ø.17"	.2"	131259
Ø.27"	Ø.25"	.4"	131260
Ø.41"	Ø.37"	.4"	131261

M2.5 x 0.45mm

D	d	L	Order No.
Ø5.2mm	Ø4.3mm	5mm	120041
Ø7mm	Ø6.5mm	10mm	120042
Ø10.5mm	Ø9.5mm	10mm	120043

Spherical Point, Carbide Tip

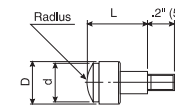

4-48UNF

D	d	Radius	L	Order No.
ø.2"	ø.17"	.2"	.2"	131273
ø.27"	ø.16"	.16"	.4"	131274
ø.41"	ø.37"	.4"	.4"	131275

M2.5 x 0.45mm

D	d	Radius	L	Order No.
ø5.2mm	ø4.3mm	5mm	5mm	120058
ø7mm	ø6.5mm	7mm	10mm	120059
ø10.5mm	ø9.5mm	10mm	10mm	120060

Needle point, Carbide tipped

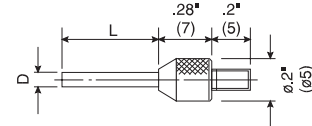

4-48UNF

D	L	Order No.
ø.018"	.12"	131281
ø.04"	.12"	131280
ø.06"	.5"	131279
ø.078"	.04"	131271

M2.5 x 0.45mm

D	L	Order No.
ø0.45mm	2.5mm	120066
ø1mm	2.5mm	120065
ø1.5mm	13mm	120064
ø2mm	1mm	120056
ø2mm	8mm	137257

ø.2" (ø5mm) Flat Point

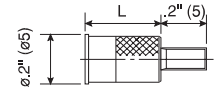

4-48UNF

L	Order No.
5/16"	133017
1/2"	21AAA043
3/4"	21AAA044
1"	21AAA045

M2.5 x 0.45mm

L	Order No.
8mm	131365

Knife edge point, Carbide tipped

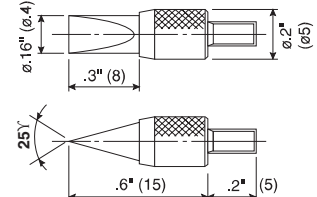

4-48UNF

Order No.
131282

M2.5 x 0.45mm

Order No.
120067

Spherical point

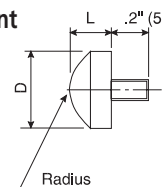

4-48UNF

D	L	Radius	Order No.
ø.5"	.125"	.28"	101205
ø.375"	.09375"	.35"	101204

M2.5 x 0.45mm

D	L	Radius	Order No.
ø10mm	5mm	7mm	101119

Mitutoyo

Contact Points

Optional Accessories for Digimatic and Dial Indicators and Linear Gages

60° Conical point

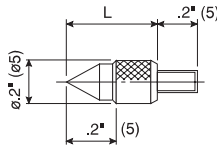

4-48UNF	
L	Order No.
1/2"	101190

M2.5 x 0.45mm	
L	Order No.
10mm	101120

90° Conical point, Carbide tipped

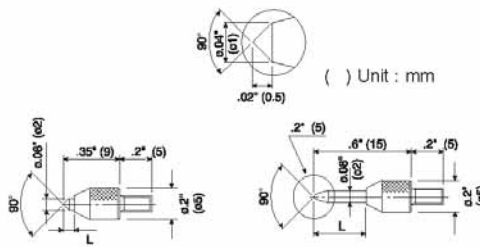

4-48UNF	
L	Order No.
.08"	131272

4-48UNF	
L	Order No.
.3"	131283

M2.5 x 0.45mm	
L	Order No.
2mm	120057

M2.5 x 0.45mm	
L	Order No.
8mm	120068

90° Conical point

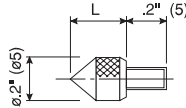

4-48UNF	
L	Order No.
1/4"	101191

M2.5 x 0.45mm	
L	Order No.
5mm	101385

Blade Point, Carbide Tip

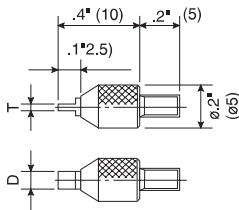

4-48UNF		
D	T	Order No.
.08"	.016"	131276
.08"	.024"	131277
.16"	.04"	131278

M2.5 x 0.45mm		
D	T	Order No.
2mm	0.4mm	120061
2mm	0.6mm	120062
4mm	1mm	120063

Roller Point

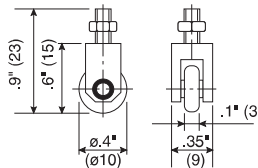

4-48UNF	
Order No.	Order No.
901991	901954

M2.5 x 0.45mm	
Order No.	Order No.
901991	901954

Extension Rod

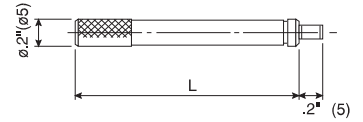

4-48UNF	
L	Order No.
1/2"	139167
1"	301655
2"	301657
4"	301659

M2.5 x 0.45mm	
L	Order No.
10mm	303611
20mm	303612
30mm	303613
100mm	303614

Point Conversion

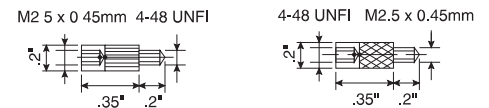

Order No.
21AAA011

Order No.
21AAA012

Lever Point

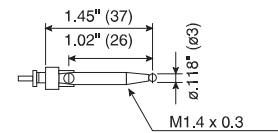

4-48UNF	
Order No.	Order No.
900393	900391

M2.5 x 0.45mm	
Order No.	Order No.
900393	900391

Interchangeable Contact Point Set (4-48 UNF)

Set Order No. 21AZA034

Individual No.	Description
101184	Shell Type Point 5/32"
101185	Shell Type Point 1/2"
101186	Shell Type Point 3/4"
101187	Shell Type Point 1"
101188	Flat Point ϕ 1/2"
101189	Flat Point ϕ 3/8"
101190	60° Conical Point
101191	90° Conical Point
101204	Spherical Point ϕ 3/8"
21AAA030	Needle Point .6"

Interchangeable Carbide Contact Point Set (4-48 UNF)

Set Order No. 21AZA035

Individual No.	Description
131260	Flat Point ϕ 1/4"
131274	Spherical Point ϕ 1/4"
131279	Needle Point ϕ .06" 1/2" Long
131262	Ballpoint ϕ .118"
131271	Needle Point ϕ .078" .04" Long

Interchangeable Contact Point Set (M2.5x0.45)

Set Order No. 7822



Individual No.	Description
131365	Flat Point (ϕ 5mm)
101117	Flat Point (ϕ 10mm)
101121	Needle Point
101119	Spherical Point
101118	Shell Type Point
101387	Shell Type Point

Spindle Lifting Lever and Cable

Optional Accessories for Digimatic and Dial Indicators

Application

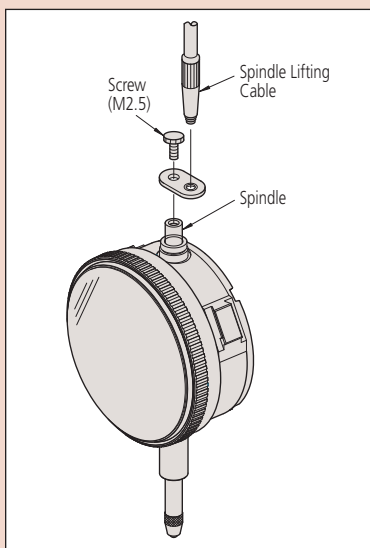
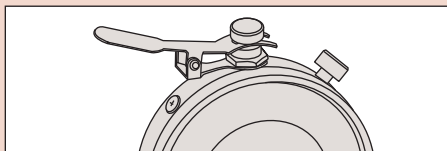
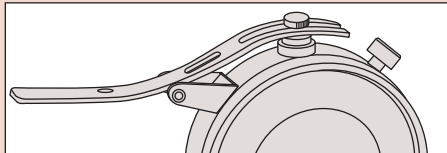

Spindle Lifting Lever

- The Spindle Lifting Lever is attached to the top end of the spindle for improved inspection efficiency when using a dial indicator mounted on a stand.

Applicable S-Type Gages

Order No.	Description
21AZB149	2,3, and 4 series up to (.5" / 12.7mm)
21AZB150	2,3, and 4 series up to (.5" / 12.7mm up to 1" / 25.4mm)
21AZB151	S-Type thickness gage



Dove Tail Type Lever Assy

Order No.	Lever up to .5" / 12.7mm	Screw	Screw Thread
21EZA198	21AZB149	101171	M2.5
21EZA199	21AZB149	101047	4/48 UNF



ANSI Screw **101047**
JIS Screw **101171**

Spindle Lifting Cable

- 901975**: with auto-stop function
- 540774**: without auto-stop function
- Lifting range: 1" / 25.4mm
- Cable length: 300mm



Spindle Lifting Knob

- 137693**
- Applicable spindle diameter; 4.8mm



Use for Series 1 dial indicators.(up 5mm / .25")

Set Order No.	Lever	Screw	Screw Thread
21BZA610	900527	101047	4-48 UNF
21BZA205	900527	101171	M2.5 x 0.45



Use for Series 2 dial indicators (up to 10mm/.4")

Set Order No.	Lever	Screw	Screw Thread
902794	900525	101047	4-48 UNF
902011	900525	101171	M2.5 x 0.45



Use for Series 2 dial indicators (up to 10mm/.4") and 1 Group S-Type

Set Order No.	Lever	Screw	Screw Thread
21BZA613	21BZA612	101047	4-48 UNF
902100	21BZA612	101171	M2.5 x 0.45



Use for Series 2 dial indicators (up to 20mm/.8") and Series 3 and 4 dial indicators (up to 10mm/.4")

Set Order No.	Lever	Screw	Screw Thread
903425	903307	192753	4-48 UNF
903424	903307	192686	M2.5 x 0.45



Spindle Lifting Knob

Set Order No.	Range
21EZA197	For 1" range
21EZA200	For 2" range



Color Spindle Caps

Optional Accessories for Digimatic and Dial Indicators

8 colors of spindle caps are available for dial indicators with a range of 10mm or less.

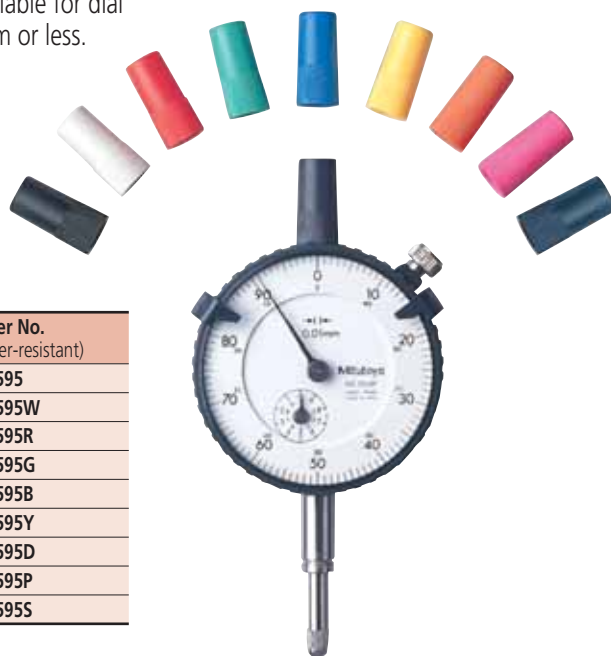

SPECIFICATIONS

Color	Order No. (normal)	Order No. (water-resistant)
Black	193051	193595
White	193051W	193595W
Red	193051R	193595R
Green	193051G	193595G
Blue	193051B	193595B
Yellow	193051Y	193595Y
Orange	193051D	193595D
Pink	193051P	193595P
Dark blue	193051S	193595S

Limit Stickers

Optional Accessories for Digimatic and Dial Indicators

FEATURES

- Stuck on the dial face or crystal of a Series 2 dial indicator (55.6mm or 57mm bezel dia.) to indicate tolerance limits.



136420: Red (10-sheet/set)



136421: Green (10-sheet/set)



136422: Yellow (10-sheet/set)

Dial Indicator Repair Tool Kit

Optional Accessories for Digimatic and Dial Indicators

Order No. 7823

Set Configuration

- (1) 901171: Molykote (lubricant)
- (2) 21JAA313: Lubricating oil
- (3) 901173: Screwdriver (Phillips)
- (4) 901174: Screwdriver (Phillips/flat blade)
- (5) 129729: Tweezers
- (6) 901175: Pin-vise
- (7) 901176: Brush
- (8) 21JAA314: Stick
- (9) 901177: Brush
- (10) 901178: Hammer
- (11) 129730: Spindle rest
- (12) 129731: Pin rest
- (13) 901179: Nippers
- (14) 901180: Pliers
- (15) 901181: Hand remover
- (16) 129732: Pin remover
- (17) 129733: Punch
- (18) 129734: Bearing adjuster
- (19) 129735: Pinion rest
- (20) 129736: Reamer $\varnothing 1$
- (21) 193702: Reamer $\varnothing 0.6$
- 21JAA273: Reamer $\varnothing 0.5$
- (21) 901182: Case

Optional Accessories For Hand Remover

- 126630: Interchangeable Pin, 0.8mm DIA.
- 126630B: Interchangeable Pin, 0.5mm DIA.
- 126630C: Interchangeable Pin, 1.6mm DIA.

Mitutoyo offers a tool set designed to let you perform simple repairs to your Mitutoyo dial indicator, and a device that lets you reset the indicator crystals.

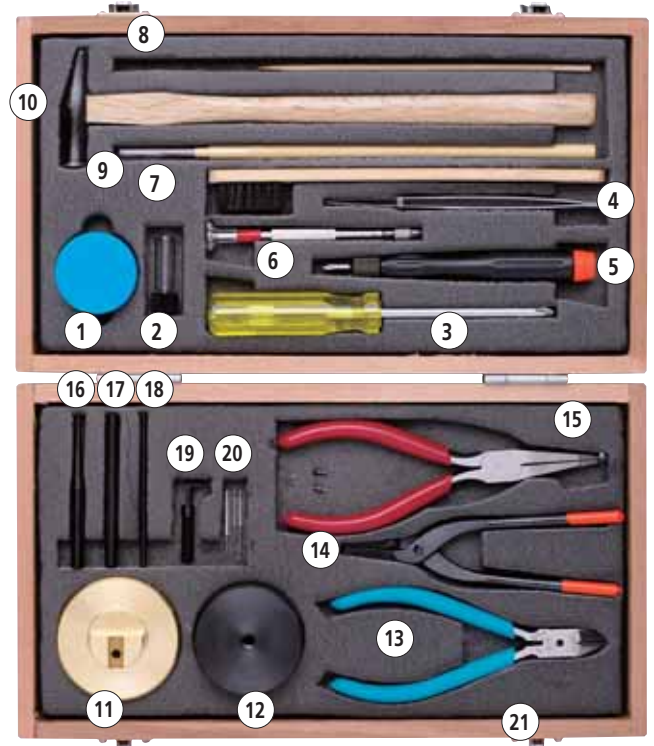

7823

SPECIFICATIONS

Order No.	Description
7823	Dial indicator repair tool kit

Dial Indicator Crystal Setter

Optional Accessories for Test and Dial Indicators

FEATURES

- Used for fitting a crystal on dial indicators, dial test indicators, and dial calipers.



7000

With 8 sizes of crystal setting pads

SPECIFICATIONS

Order No.	Description
7000	Dial indicator crystal setter

Mitutoyo







Dial Test Indicators

SERIES 513

FEATURES

- Narrow or deep places, which cannot be measured with a normal dial gauge, can be easily and accurately measured.
- Mitutoyo's proprietary new structure permits smooth pointer operation.
- Use of a hard frame body provides excellent rigidity and durability.
- Non-magnetic pointer and contact point permit secure operation even in environments with magnetism.
- Use of a clear and concise wide dial face allows excellent visibility.
- The surface of the crystal is hard-coated, to make it scratch-resistant.
- Flat crystal makes gradations easy to read. Moreover, the unified structure of the outer frame prevents oil and water from permeating via the front face.
- Six types are available: vertical, inclined, perpendicular, horizontal, universal, and pocketable, allowing users to select the model most suited to their needs.
- Vertical: Standard
- Inclined: Dial face inclined 20°, compared with the vertical type, allows easy reading.
- Perpendicular: Best suited for centering holes.
- Horizontal: The graduations can be read from the front, with the probe on the tip of the horizontal conical rod abutting the workpiece.
- Universal: The direction of the probe movement can be freely changed.
- Pocketable: Compact type

Description of Icon

Icon	Description
	With revolution counter type
	Long contact point type
	Jeweled bearing type
	Double scale spacing type, easy-on-the-eyes
	Compact type
	Dustproof type
	Anti-magnetic type

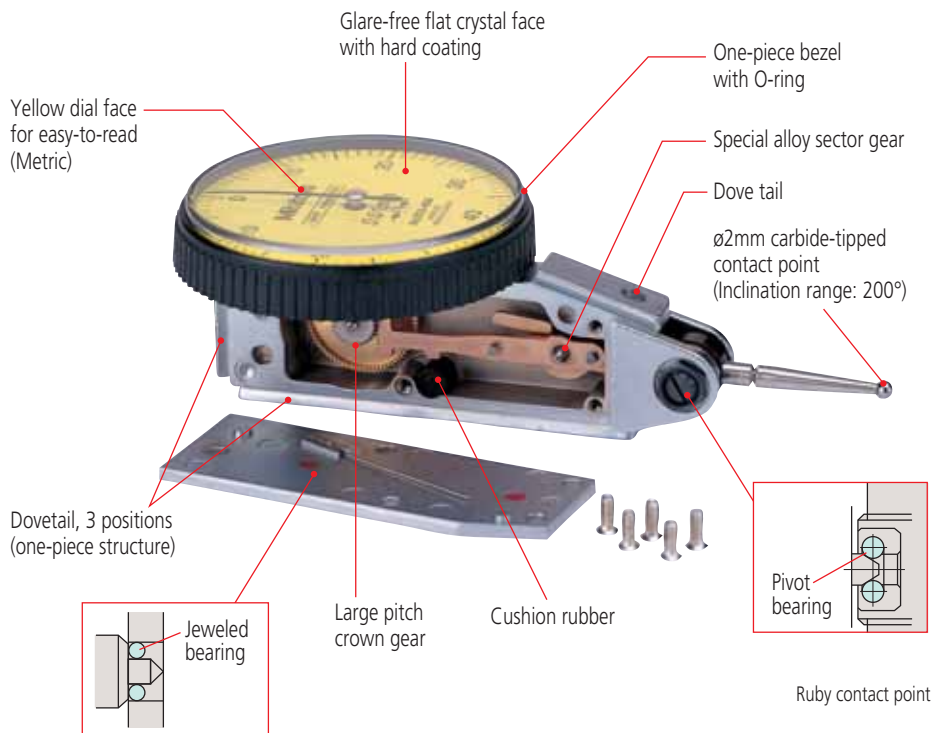

Dial Test Indicators

SERIES 513 — Horizontal Type

Optional Accessories

- : Swivel clamp
- : Holding bar
- : Stem
- : Contact points

Special Set: No. 513-908 (mm)

- 513-404E: Dial test indicator
- 7014: Mini magnetic stand

No. 513-907 (inch)

- 513-402: Dial test indicator
- 7014E: Mini magnetic stand



FEATURES

- Performs easy and accurate measurement of narrow or recessed areas, plus inside and outside diameters that dial indicators cannot access.
- No-clutch structure for automatic reversal of measuring direction.
- Resistant to water and dust thanks to the one-piece bezel and "crystal" design with O-ring.
- The glare-free flat crystal face has a scratch-resistant coating.
- High-sensitivity and quick-response because of jeweled bearings.
- A carbide contact point is provided as standard.



513-424E



513-404E



513-414E



513-403



513-474E



513-466E



513-464E



513-463

SPECIFICATIONS

Metric

Graduation	Order No.		Range	Accuracy	Dial reading	Measuring force	L (mm)						
	Basic set	Full set											
0.01mm	513-424E	513-424T	0.5mm	5μm	0-25-0	0.3N or less	22.3	✓	✓	—	✓	—	—
0.01mm	513-414E	513-414T	0.5mm	10μm	0-25-0	0.2N or less	36.8	✓	✓	✓	✓	—	—
0.01mm	513-466E	—	0.5mm	5μm	0-25-0	0.3N or less	22.3	✓	✓	—	✓	✓	—
0.01mm	513-404E	513-404T	0.8mm	8μm	0-40-0	0.3N or less	20.9	✓	—	—	✓	—	—
0.01mm	513-474E*	—	0.8mm	8μm	0-40-0	0.3N or less	20.9	✓	—	—	✓	—	—
0.01mm	513-464E	—	0.8mm	8μm	0-40-0	0.3N or less	20.9	✓	—	—	✓	✓	—
0.01mm	513-415E	513-415T	1mm	10μm	0-50-0	0.2N or less	44.5	✓	—	✓	✓	—	—
0.01mm	513-426E	—	1.5mm	8μm	0-25-0	0.4N or less	22.3	✓	✓	—	✓	—	✓
0.002mm	513-405E	513-405T	0.2mm	3μm	0-100-0	0.3N or less	14.7	✓	—	—	✓	—	—
0.002mm	513-465E	—	0.2mm	3μm	0-100-0	0.3N or less	14.7	✓	—	—	✓	✓	—
0.002mm	513-425E	—	0.6mm	6μm	0-100-0	0.4N or less	14.7	✓	—	—	✓	—	✓
0.001mm	513-401E	—	0.14mm	3μm	0-70-0	0.3N or less	12.8	✓	—	—	✓	—	—

*provided with a ø2mm ruby contact point as a substitute for ø2mm carbide contact point.

Inch

Graduation	Order No.		Range	Accuracy	Dial reading	Measuring force	L (mm)					
	Basic set	Full set										
.0005"	513-402	513-402T	.03"	±.0005"	0-15-0	0.3N or less	19.9	✓	—	✓	—	—
.0005"	513-412	513-412T	.03"	±.0005"	0-15-0	0.2N or less	33.9	✓	✓	✓	—	—
.0005"	513-462	—	.03"	±.0005"	0-15-0	0.3N or less	19.9	✓	—	✓	✓	—
.0001"	513-403	513-403T	.008"	±.0001"	0-4-0	0.3N or less	15	✓	—	✓	—	—
.0001"	513-463	—	.008"	±.0001"	0-4-0	0.3N or less	15	✓	—	✓	✓	—

Metric/inch

Graduation	Order No.		Range	Accuracy	Dial reading	Measuring force	L (mm)		
	Basic set	Full set							
0.002mm, .0001"	513-409	513-409T	0.2mm, .0075"	3μm	0-10-0, 0-38-0	0.3N or less	14.7	✓	✓

Inch/Metric

Graduation	Order No.		Range	Accuracy	Dial reading	Measuring force	L (mm)		
	Basic set	Full set							
.0005", 0.01mm	513-406	513-406T	.03", 0.7mm	±.0005"	0-15-0, 0-35-0	0.3N or less	19.9	✓	✓

DIMENSIONS AND MASS

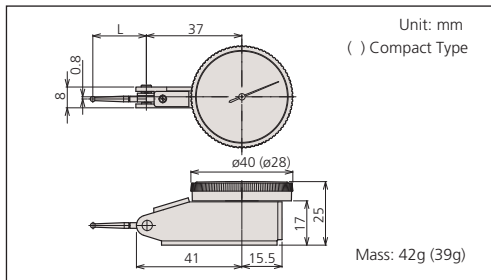

Set Configuration: Metric Test Indicators

Full set



Basic set

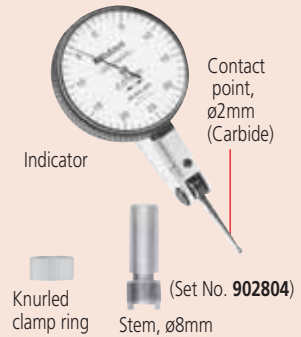

Set Configuration: Inch Test Indicators

Full set

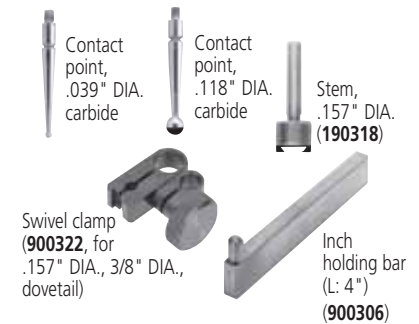

Basic set

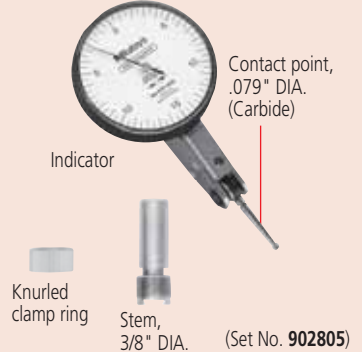

Dial Test Indicators

SERIES 513 — Horizontal (20° Tilted Face), Vertical, and Parallel Types



FEATURES

- Specially designed for easy viewing of measurements.

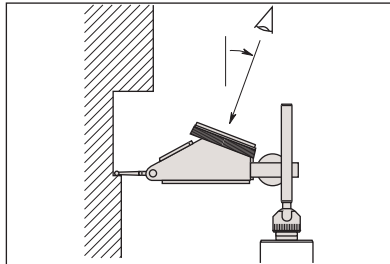

- The dial face obliquely faces upward, allowing users to read the graduations from the user's side. It is convenient when measuring on the side of a large workpiece and the workbench is high.

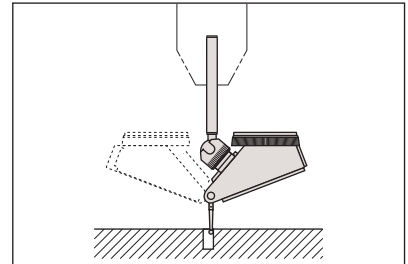

- Using the universal holder allows easy hole centering. The dial face always faces upward when the indicator is rotated, which makes reading easy.



513-444E



513-445E



513-454E
513-284GE



513-455E



513-452



513-282G



513-444E



513-445E



513-284G



513-442



513-446

Optional Accessories

- : Swivel clamp
- : Holding bar
- : Stem
- : Contact points

Mitutoyo



Anti-magnet type



With revolution counter type



Jeweled bearing type



Long contact point type

SPECIFICATIONS

Metric Horizontal (20° tilted face) type

Graduation	Order No.		Range	Accuracy	Dial reading	Measuring force	Mass (g)	L (mm)			
	Basic set	Full set									
0.01mm	513-444E	513-444T	1.6mm	10µm	0-40-0	0.3N or less	48	20.9	✓	✓	✓
0.002mm	513-445E	513-445T	0.4mm	5µm	0-100-0	0.3N or less	48	14.7	✓	✓	✓

Inch Horizontal (20° tilted face) type

Graduation	Order No.		Range	Accuracy	Dial reading	Measuring force	Mass (g)	L (mm)					Remarks
	Basic set	Full set											
.0005"	513-442	513-442T	.06"	±.0005"	0-15-0	0.3N or less	48	19.9	✓	✓	✓	—	—
.0005"	513-442-01	513-442T-01	.06"	±.0005"	0-15-0	0.3N or less	48	19.9	✓	✓	✓	—	Blue dial
.0005"	513-442-06	513-442T-06	.06"	±.0005"	0-15-0	0.3N or less	48	19.9	✓	✓	✓	—	Black dial
.0005"	513-446	513-446T	.06"	±.0005"	0-15-0	0.2N or less	48	33.9	✓	✓	✓	✓	—
.0005"	513-446-06	513-446T-06	.06"	±.0005"	0-15-0	0.2N or less	48	33.9	✓	✓	✓	✓	Black dial
.0001"	513-443	513-443T	.016"	±.0002"	0-4-0	0.3N or less	48	15	✓	✓	✓	—	—
.0001"	513-443-06	513-443T-06	.016"	±.0002"	0-4-0	0.3N or less	48	15	✓	✓	✓	—	Black dial

Metric Vertical type

Graduation	Order No.		Range	Accuracy	Dial reading	Measuring force	Mass (g)	L (mm)		
	Basic set	Full set								
0.01mm	513-454E	513-454T	0.8mm	8µm	0-40-0	0.3N or less	50	20.9	✓	✓
0.002mm	513-455E	513-455T	0.2mm	3µm	0-100-0	0.3N or less	50	14.7	✓	✓

Inch Vertical type

Graduation	Order No.		Range	Accuracy	Dial reading	Measuring force	Mass (g)	L (mm)		
	Basic set	Full set								
.0005"	513-452	513-452T	.03"	±.0005"	0-15-0	0.3N or less	50	19.9	✓	✓
.0001"	513-453	513-453T	.008"	±.0001"	0-4-0	0.3N or less	50	15	✓	✓

Metric Parallel type

Graduation	Order No.		Range	Accuracy	Dial reading	Measuring force	Mass (g)	L (mm)		
	Basic set	Full set								
0.01mm	513-284GE	513-284GT	0.8mm	8µm	0-40-0	0.3N or less	68	20.9	✓	✓

Inch Parallel type

Graduation	Order No.		Range	Accuracy	Dial reading	Measuring force	Mass (g)	L (mm)		
	Basic set	Full set								
.0005"	513-282G	513-282GT	.03"	±.0005"	0-15-0	0.3N or less	68	20	✓	✓

DIMENSIONS

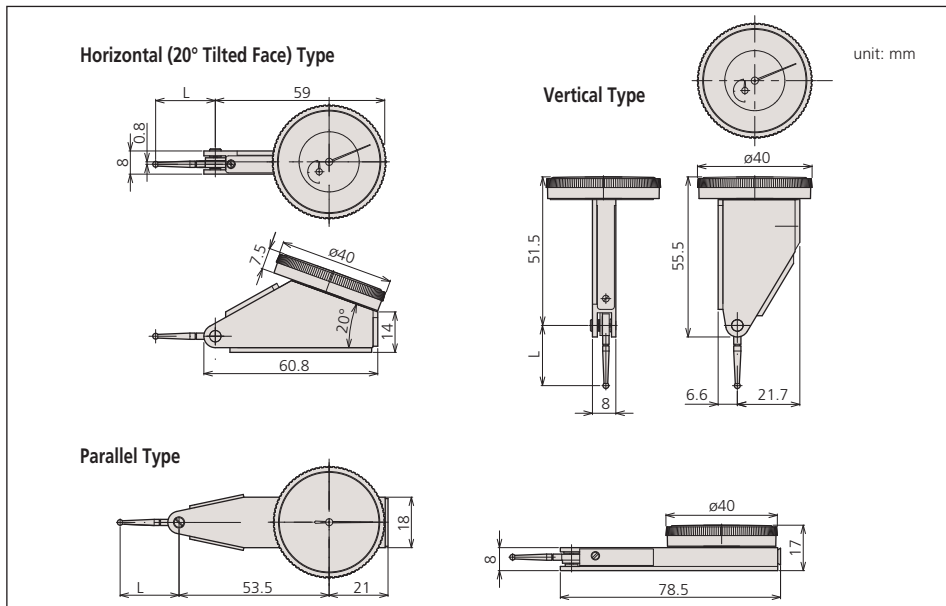

Set Configuration: Metric

Full set



Basic set

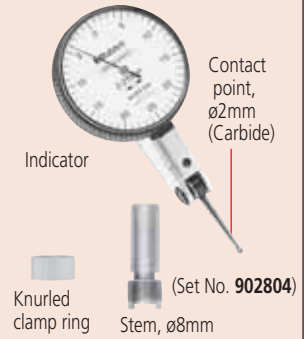

Set Configuration: Inch

Full set

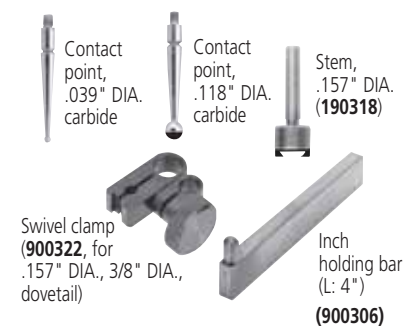

Basic set

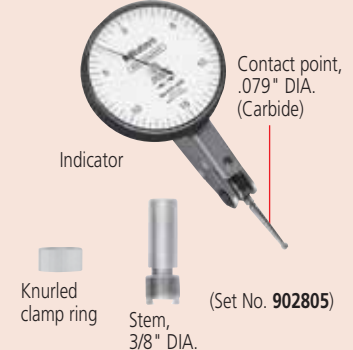

Pocket Type Dial Test Indicators

SERIES 513

FEATURES

- Jeweled bearings assure higher sensitivity and accuracy.
- Reversible measuring direction.
- Two holding bars are supplied. (Full sets only.)
- Fully adjustable bezel/dial face.
- Contact point is adjustable within 220°.
- Bezel is sealed with an O-ring to keep out water / oil.



513-514E



513-517E
513-527E



513-515T



513-503E



513-501E

Optional Accessories

- : Swivel clamp
- : Holding bar
- : Stem
- : Contact points

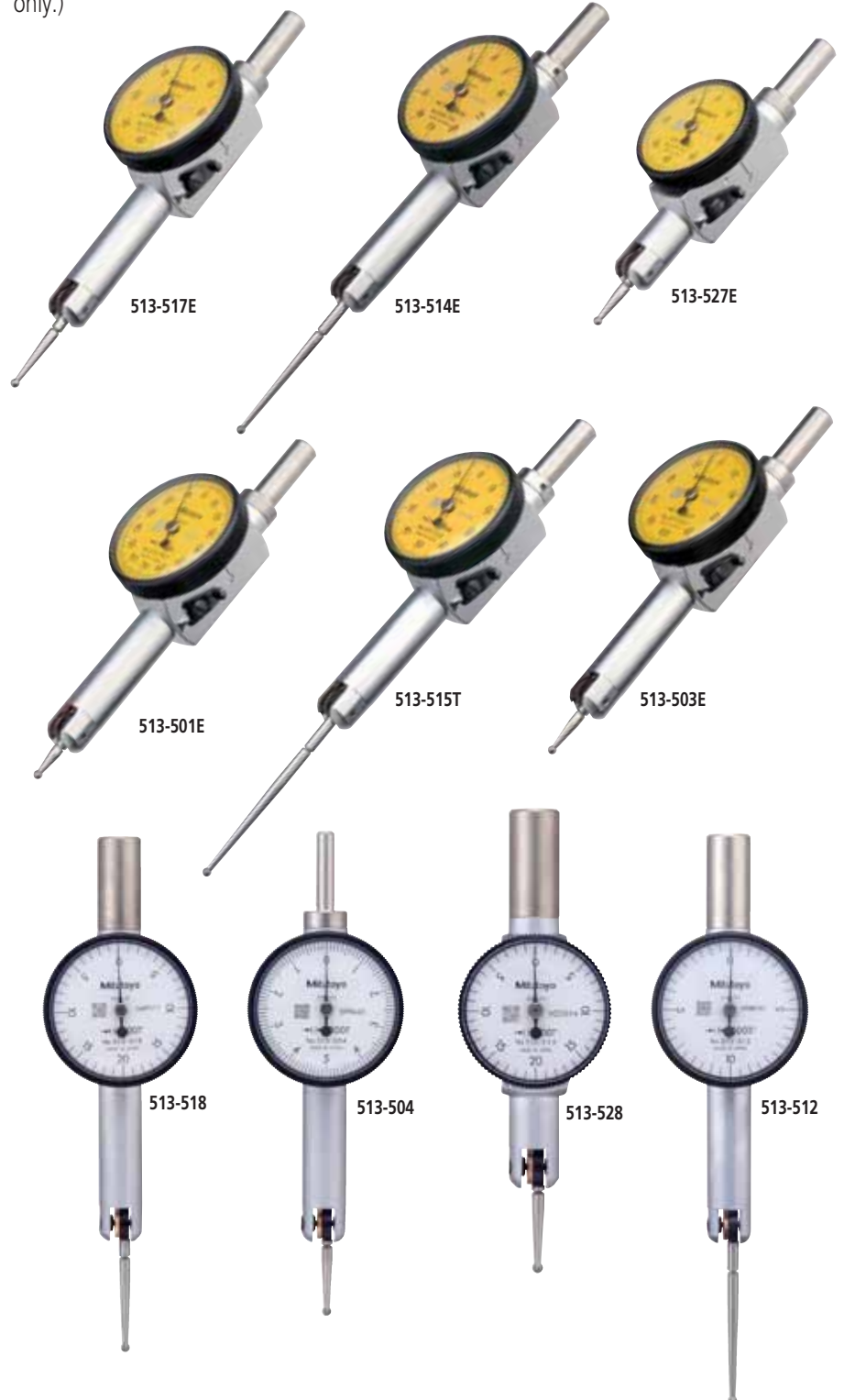

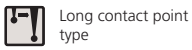

Long contact point type



Jeweled bearing type



Compact type

SPECIFICATIONS

Metric

Graduation	Order No.		Range	Accuracy	Dial reading	Measuring force	L (mm)			
	Basic set	Full set								
0.01mm	513-514E	513-514T	0.5mm	10µm	0-25-0	0.3N or less	36.8	✓	✓	—
0.01mm	513-517E	513-517T	0.8mm	8µm	0-40-0	0.3N or less	20.9	—	✓	—
0.01mm	513-527E	513-527T	0.8mm	8µm	0-40-0	0.3N or less	14.7	—	✓	✓
0.01mm	—	513-515T	1mm	10µm	0-50-0	0.3N or less	44.5	✓	✓	—
0.002mm	513-503E	513-503T	0.2mm	3µm	0-100-0	0.3N or less	14.7	—	✓	—
0.001mm	513-501E	513-501T	0.14mm	3µm	0-70-0	0.4N or less	12	—	✓	—

Inch

Graduation	Order No.		Range	Accuracy	Dial reading	Measuring force	L (mm)			
	Basic set	Full set								
.001"	513-518	513-518T	.04"	±.001"	0-20-0	0.3N or less	26.5	—	✓	—
.001"	513-528	513-528T	.04"	±.001"	0-20-0	0.3N or less	18.7	—	✓	✓
.0005"	513-512	513-512T	.02"	±.0005"	0-10-0	0.3N or less	37.4	✓	✓	—
.0001"	513-504	513-504T	.01"	±.0002"	0-5-0	0.3N or less	18.7	—	✓	—

Optional Contact Points

Pocket Type

Order No.	1mm	2mm	3mm	0.5mm	0.7mm
513-501E	136756	136104	136758	—	—
513-503E 513-527E	103017	103010	103018	190547	190548
513-504 513-528	131314	103011	131315	—	—
513-512	131316	131324	131317	—	—
513-514E	137746	129949	137747	—	—
513-515T	136235	136013	136236	190656	190655
513-517E	103013	103006	103014	190549	190550
513-518	103008	103007	103009	—	—

DIMENSIONS AND MASS

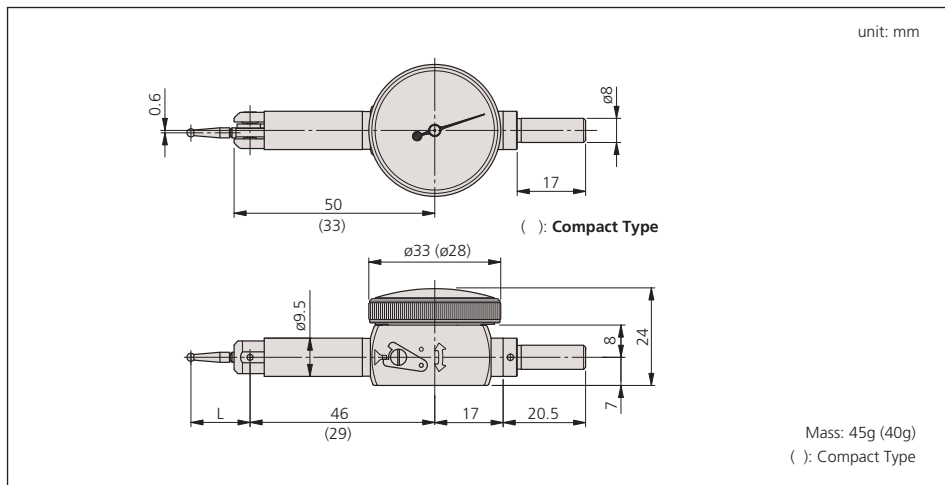

Set Configuration: Metric

Full set

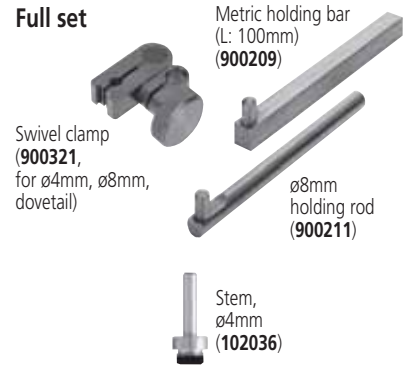

Basic set

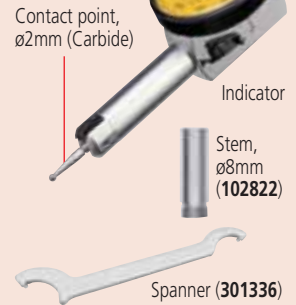

Set Configuration: Inch

Full set



Basic set

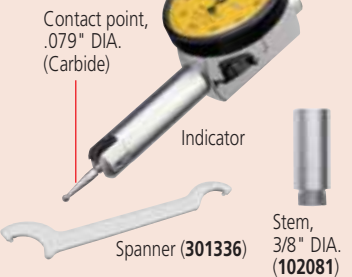

Set Configuration: Metric

Full set

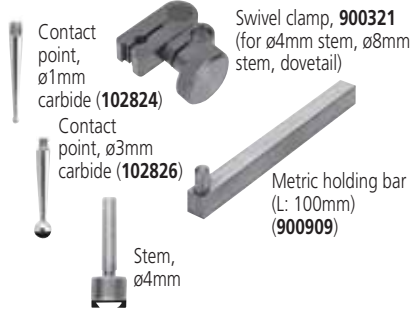

Basic set

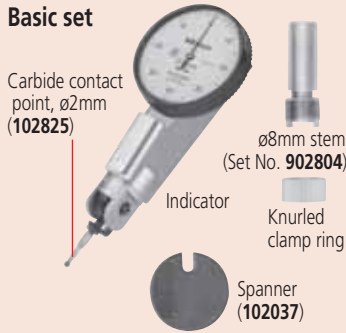

Set Configuration: Inch

Full set

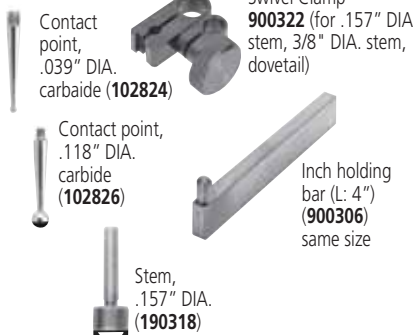

Basic set

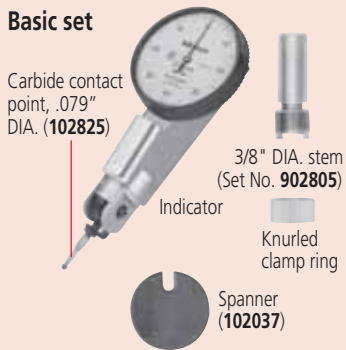

Optional Accessories

- : Swivel clamp
- : Holding bar
- : Stem

Dial Test Indicators

SERIES 513 — Universal Type

FEATURES

- Universal application to all directions. (Not only the direction of the measuring point, but also the direction of measurement itself can be adjusted 360 degrees without moving the indicator.)

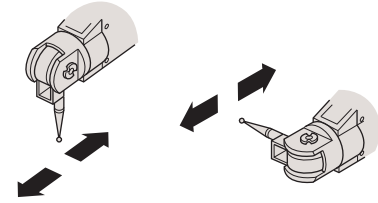

513-304GE

SPECIFICATIONS



Graduation	Order No.		Range	Accuracy	Dial reading	Measuring force	Jeweled bearing type
	Basic set	Full set					
0.01mm	513-304GE	513-304GT	0.8mm	8µm	0-40-0	0.3N or less	✓

Inch

Graduation	Order No.		Range	Accuracy	Dial reading	Measuring force	Jeweled bearing type
	Basic set	Full set					
.0005"	513-302G	513-302GT	.03"	±.0005"	0-15-0	0.3N or less	✓

DIMENSIONS AND MASS

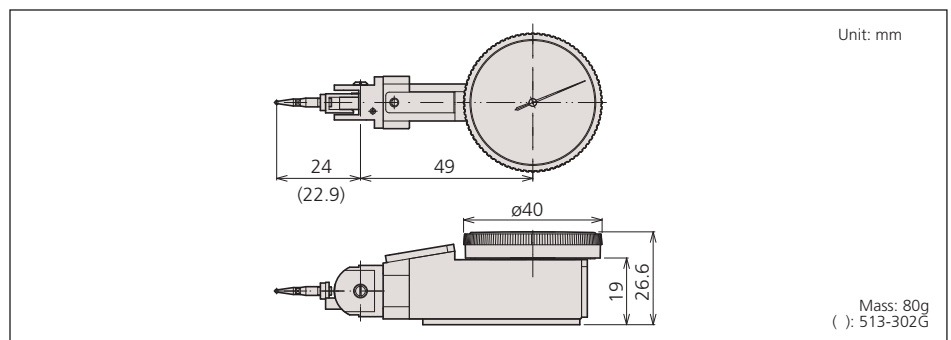

Contact Points and Clamp Holders

Optional Accessories for Dial Test Indicator

Contact Points

Order No.	1mm	2mm	3mm	0.5mm	0.7mm
513-401E	21CZA044	21CZA036	21CZA045		
513-405E	103017	103010	103018	190547	190548
513-465E					
513-455E					
513-404E	103013	103006	103014	190549	190550
513-444E					
513-284GE					
513-424E	137558	137557	137559	190654	190653
513-426E					
513-415E	136235	136013	136236	190656	190655
513-414E	137746	129949	137747		
513-402	133196	133195	133197		
513-406					
513-442-01					
513-452					
513-403	136076	136075	136077		
513-443					
513-453					
513-412	136291	136290	136292		
513-446-06					

Holding Bars



Centering Holder

- Allows large diameter cylinders or holes to be centered.

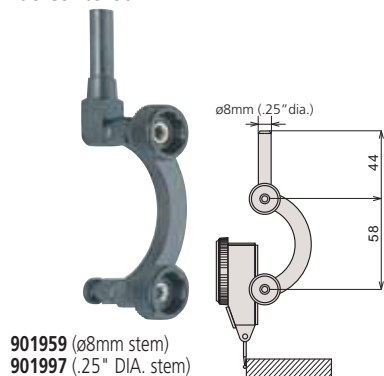

Universal Holder

- Allows the indicator to be set at a desired position.

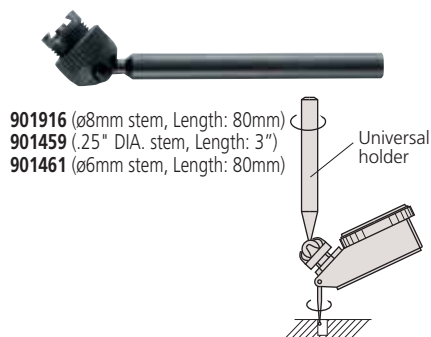

Universal Holder (pocket type)

- Since the Dial Test Indicator can be swiveled to a desired angle, the holder is useful for centering workpieces and installing workpieces on a milling machine.

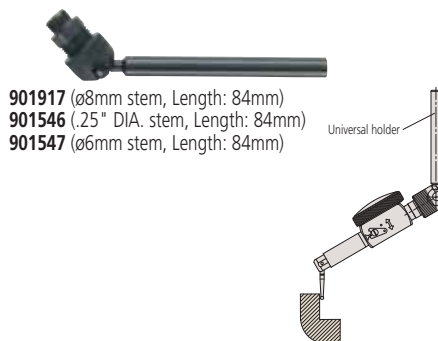

Technical Data

Measuring Range: 100mm/4"
 Resolution: 0.02µm/1.24µin
 Accuracy: ±(0.2+L/100)µm in vertical position
 (at 20°C) ±(0.3+2L/100)µm in lateral position
 L = arbitrary length (mm)
 Drive method: Motor drive
 Measuring Unit: Reflective-type metal linear encoder
 Thermal expansion coefficient: (8±1)X10⁻⁶/K
 Measurement: Semi-automatic measurement
 Method: Fully automatic measurement*
 Dimensions: 184 x 225 x 532mm (W x D x H)
 Operating temperature range: 20°C±3°C
 Power supply: 100VAC to 240VAC ±10%, 50/60Hz
 Mass: 20kg

* Full automatic measurement requires the SPC cable for indicator connection. Additionally some form of indicator, along with a connecting machine (the optional accessory for indicator as a Digimatic power-supply unit on EF counter) will be needed.

Function

Inspect your analog indicator semi-automatically!

The pointer of the analog indicator is positioned just before the measuring point automatically via Mitutoyo's Semi-automatic Measurement function. After that, inspection begins simply by adjusting the pointer position with the jog-dial. Because of this function, measurement time is reduced and user fatigue is practically eliminated. Additionally all functions necessary for inspection are combined in the control box so that the operator need not rely on excessive eye movement to adjust the pointer.

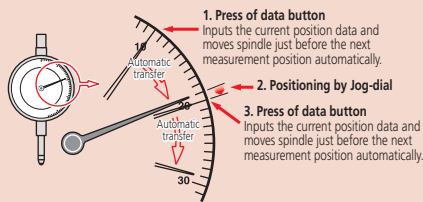

Fully automatic inspection of digital indicator

The Automatic Measurement function, in tandem with a digital indicator makes the spindle move so that measurement data is acquired automatically. Therefore, manual adjustment to the measurement position is needless and the efficiency of every inspection is enhanced.



Create and printout a simplified inspection certificate

It is possible to create, edit and print out your own inspection certificate. Further more, that data can be saved as a CSV file.

Optional Accessories

02ASK000: Test indicator attachment set (ø6mm stem)
02ASK180: Test indicator attachment set (ø8mm stem)
02ASK370: Test indicator holder (ø6mm stem)
02ASK380: Test indicator holder (ø8mm stem)
02ASK110: Bore gage accessory set
902803: ø6mm dovetail grooved stem
902804: ø8mm dovetail grooved stem
02ASK040: Stem bush ø6mm
02ASJ856: Stem bush ø8mm
02ASK150: Stem bush ø8mm, short
02ASK050: Bush ø9.5 (Requires **02ASK070**)
02ASK060: Stem bush ø12mm
02ASK070: Stem bush ø15mm
02ASK080: Stem bush ø20mm
02ASK090: Stem bush 3/8"
02ASK130: Stem bush case
02ASK730: Reflector
937179T: Foot switch
 PC system

i-Checker

SERIES 170

FEATURES

The i-Checker is specially designed to calibrate measuring accuracy of dial indicators, dial test indicators, and other electronic comparison gage heads with a stroke of up to 100mm (4").

- ±(0.2+L/100)µm indication accuracy.
- Directly inspects an indicator with a stroke of up to 100mm (4"). The dial test indicator, bore gage and lever-type inductive head can be inspected with optional accessories.

- Adjustment of the measurement position is very easily accomplished because of semi-automatic measurement and full automatic measurement functions.
- Creates and prints out the simple inspection certificate.
- Saves inspection result as CSV file for reusable inspection result by any kind of software.



* PC system is optional

SPECIFICATIONS

Order No.	Remarks
170-303A	with ø3/8" bush



DIMENSIONS

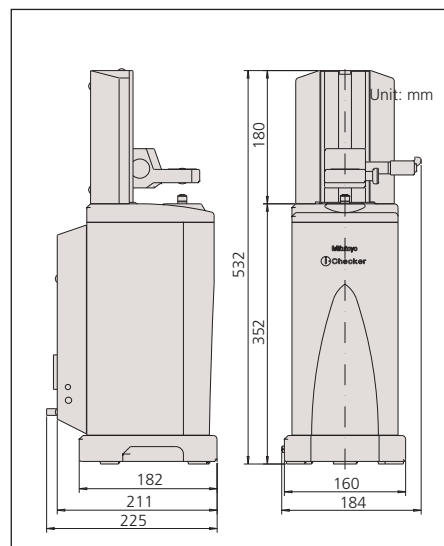

Applicable Indicators

- Dial indicator
 - Hicor
 - Digimatic indicator***
 - Test indicator*
 - Bore gage**
 - Linear gage
- * requires optional test indicator attachment set
 ** requires optional bore gage accessory
 *** requires optional SPC cable for full automatic measurement



Using test indicator attachment set (**02ASK000**)



Using bore gage accessory set (**02ASK110**)

Mitutoyo

UDT-2 Dial Gage Testers

SERIES 170

The UDT-2 Dial Gage Tester consists of a specially designed 0-1" / 0-25mm micrometer head, with a large disc, and rigid holding fixtures. Gage tester to calibrate measuring accuracy of dial indicators, dial test indicators and dial bore gage.

FEATURES

- Clamping stem diameter—
170-102-10: 6mm and 8mm,
170-101-10: .25" and .375"
- With the optional stand (**21AKK824**), inspection of Dial Bore Gages becomes possible to perform.



170-102-10

SPECIFICATIONS

Metric			
Range	Order No.	Graduation	Accuracy
0 - 25mm	170-102-10	0.001mm	±1µm

Inch			
Range	Order No.	Graduation	Accuracy
0 - 1"	170-101-10	.0001"	±.0001"

Calibration Testers

SERIES 521

The Calibration Tester is specially designed to calibrate measuring accuracy of short range dial indicators, dial test indicators, and other electronic comparison gage heads.



521-103

FEATURES

- Universal bracket accepts any dial indicator, dial test indicator, lever head of Mu-Checker without any additional accessory.
- Clamping capacity: ø4mm - ø10mm / .157" - .394" dia.
- Dual color-indexed directional graduations to facilitate measurements.

SPECIFICATIONS

Metric			
Range	Order No.	Graduation	Accuracy
0 - 1mm	521-103	0.0002mm	±0.2µm
0 - 5mm	521-105	0.0002mm	±0.8µm

Inch			
Range	Order No.	Graduation	Accuracy
0 - .05"	521-104	.00001"	±.00001"
0 - .2"	521-106	.00001"	±.00003"



Optional Accessory

21AKK824: Stand for bore gage inspection



Calibrating test indicator

Technical Data

Function of Digital Models

- IDS Types
- ON/OFF
 - Inch / mm Conversion
 - Origin
 - \pm Direction Changeover
 - SPC Output
 - Battery Life: 20,000 hrs
 - Power Supply: Silver Oxide Cell (SR-44 1pc.)

IDC Types

- ON/OFF
- Inch / mm Conversion
- Zero / ABS
- \pm Direction Changeover
- SPC Output
- Battery Life: 5,000 hrs
- Power Supply: Silver Oxide Cell (SR-44 1pc.)
- Preset
- Provides GO / \pm NG Judgement
- Face Rotates 330°

DIMENSIONS

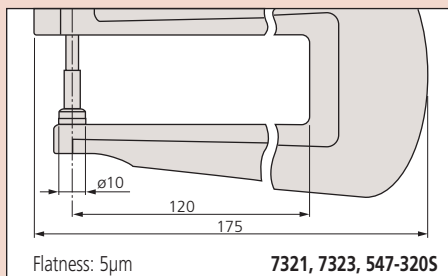
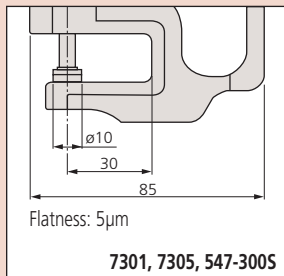

Thickness Gages

SERIES 547, 7

The Thickness Gages offer a quick and efficient means of inspection with their convenient grip handle, thumb trigger and spring-loaded spindle. The various models cover a wide range of applications.

FEATURES

- Wide range of applications with various types of measuring faces (on the spindle and anvil).

- The digital models incorporate Mitutoyo's popular ID-C and ID-S Series Digimatic Indicators to provide error-free LCD readings as well as data output for SPC analysis.
- 547-400S is ideally suited for measuring thicknesses of paper, film, wire, sheet metal and similar materials.

Flat Anvil Type

Standard Type / Digital



Deep Throat Type / Digital



Deep Throat Type / Dial

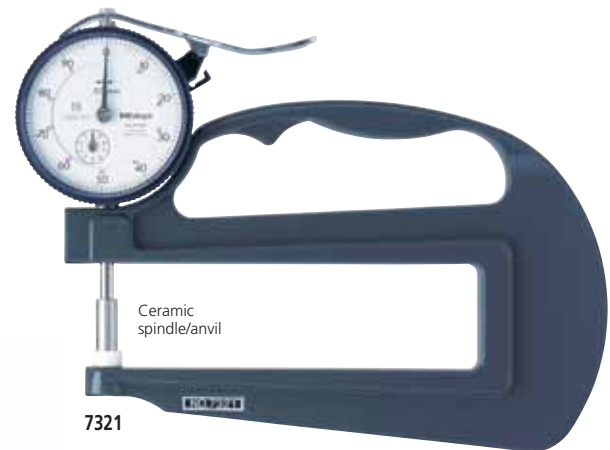

High Accuracy Type / Digital



DIMENSIONS

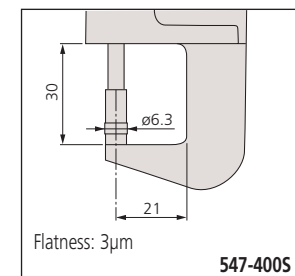

Thickness Gages

SERIES 547, 7

Flat Anvil Type

SPECIFICATIONS

Inch/Metric		Digital Type			
Range	Order No.	Resolution	Accuracy	Measuring force	Indicator
0 - .47" / 0 - 12mm	547-500	.0005"/0.01mm	±.001"	1.5N or less	Digimatic IDS
0 - .47" / 0 - 12mm	547-520	.0005"/0.01mm	±.001"	1.5N or less	Digimatic IDS
0 - .47" / 0 - 12mm	547-526	.0001"/0.001mm	±.0002"	1.5N or less	Digimatic IDS
0 - .4" / 0 - 10mm	547-3005	.0005"/0.01mm	±.001"	1.5N or less	Digimatic IDC
0 - .4" / 0 - 10mm	547-3205	.0005"/0.01mm	±.001"	1.5N or less	Digimatic IDC
0 - .47" / 0 - 12mm	547-4005	.00005"/0.001mm	±.00015"	3.5N or less	Digimatic IDC

Inch		Dial Type			
Range	Order No.	Graduation	Accuracy	Measuring force	Remarks
0 - .05"	73265	.00005"	±.0002"	1.4N or less	Fine dial reading, ceramic spindle/anvil
0 - .5"	73005	.001"	±.001"	1.4N or less	Standard, ceramic spindle/anvil
0 - 1"	73045	.001"	±.002"	2.0N or less	Standard, ceramic spindle/anvil
0 - 1"	73225	.001"	±.002"	2.0N or less	Deep throat, ceramic spindle/anvil

Metric		Dial Type			
Range	Order No.	Graduation	Accuracy	Measuring force	Remarks
0 - 1mm	7327	0.001mm	±5µm	1.4N or less	Fine dial reading, ceramic spindle/anvil
0 - 10mm	7301	0.01mm	±15µm	1.4N or less	Standard, ceramic spindle/anvil
0 - 20mm	7305	0.01mm	±20µm	2.0N or less	Standard, ceramic spindle/anvil
0 - 10mm	7321	0.01mm	±15µm	1.4N or less	Deep throat, ceramic spindle/anvil
0 - 20mm	7323	0.01mm	±22µm	2.0N or less	Deep throat, ceramic spindle/anvil

Lens thickness measurement (reverse anvil)



547-3125

7313

SPECIFICATIONS

Inch/Metric		Digital Type			
Range	Order No.	Resolution	Accuracy	Measuring force	Indicator
0 - .47" / 0 - 12mm	547-512	.0005"/0.01mm	±.001"	1.5N or less	Digimatic IDS
0 - .47" / 0 - 12mm	547-3125	.0005"/0.01mm	±.001"	1.5N or less	Digimatic IDC

Inch		Dial Type			
Range	Order No.	Graduation	Accuracy	Measuring force	Remarks
0 - .5"	73125	.001"	±.001"	1.4N or less	Lens thickness

Metric		Dial Type			
Range	Order No.	Graduation	Accuracy	Measuring force	Remarks
0 - 10mm	7313	0.01mm	±15µm	1.4N or less	Lens thickness

Optional Accessories

- 905338:** SPC cable (40" / 1m) for digital type
- 905409:** SPC cable (80" / 2m) for digital type
- 902794:** Spindle lifting lever for IDS digimatic type (stroke .5" / 12.7mm)
- 21AZB149:** Spindle lifting lever for digimatic and dial thickness gage (stroke .5" / 12.7mm)
- 21AZB150:** Spindle lifting lever for dial indicator (stroke 1" / 25.4mm)

DIMENSIONS

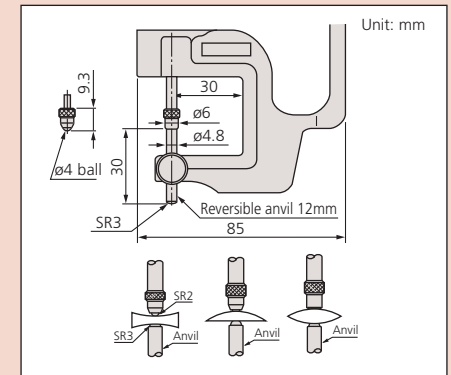

Unit: mm

Thickness Gages

SERIES 547, 7

DIMENSIONS

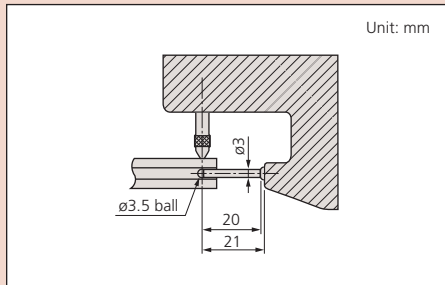

Optional Accessories

- 905338: SPC cable (40" / 1m) for digital type
- 905409: SPC cable (80" / 2m) for digital type
- 902794: Spindle lifting lever for IDS digimatic type (stroke .5" / 12.7mm)
- 21AZB149: Spindle lifting lever for digimatic and dial thickness gage (stroke .5" / 12.7mm)
- 21AZB150: Spindle lifting lever for dial indicator (stroke 1" / 25.4mm)

DIMENSIONS

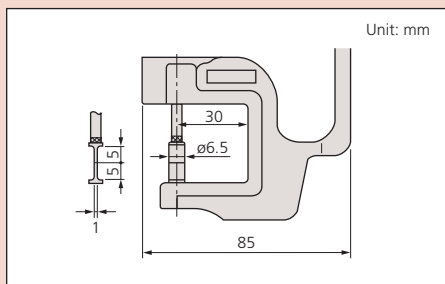

Tube thickness measurement



547-3615

SPC
ABSOLUTE
Mitsubishi Precision



7360

SPECIFICATIONS

Inch/Metric Digital Type

Range	Order No.	Resolution	Accuracy	Measuring force	Indicator
0 - .47" / 0 - 10mm	547-561	.0005"/0.01mm	±.001"	1.5N or less	Digimatic IDS
0 - .47" / 0 - 12mm	547-3615	.0005"/0.01mm	±.001"	1.5N or less	Digimatic IDC

Inch Dial Type

Range	Order No.	Graduation	Accuracy	Measuring force	Remarks
0 - .5"	73615	.001"	±.001"	1.4N or less	Tube thickness

Metric Dial Type

Range	Order No.	Graduation	Accuracy	Measuring force	Remarks
0 - 10mm	7360	0.01mm	±15µm	1.4N or less	Tube thickness

Groove thickness measurement (Blade anvil type)



547-3165

SPC
ABSOLUTE
Mitsubishi Precision



7315

SPECIFICATIONS

Inch/Metric Digital Type

Range	Order No.	Resolution	Accuracy	Measuring force	Indicator
0 - .47" / 0 - 12mm	547-516	.0005"/0.01mm	±.001"	1.5N or less	Digimatic IDS
0 - .47" / 0 - 10mm	547-3165	.0005"/0.01mm	±.001"	1.5N or less	Digimatic IDC

Inch Dial Type

Range	Order No.	Graduation	Accuracy	Measuring force	Remarks
0 - .5"	73165	.001"	±.001"	1.4N or less	Groove thickness

Metric Dial Type

Range	Order No.	Graduation	Accuracy	Measuring force	Remarks
0 - 10mm	7315	0.01mm	±15µm	1.4N or less	Groove thickness

Thickness Gages

SERIES 547, 7

Universal Type (interchangeable anvils)



547-528

SPECIFICATIONS

Inch/Metric Digital Type

Range	Order No.	Resolution	Accuracy	Measuring force	Indicator
0 - .47" / 0 - 12mm	547-528	.0005"/0.01mm	±.001"	1.5N or less	Digimatic IDS

Inch Dial Type

Range	Order No.	Graduation	Accuracy	Measuring force	Remarks
0 - .4"	73285	.001"	±.001"	1.5N or less	Interchangeable anvils

Optional Accessories

- 905338:** SPC cable (40" / 1m) for digital type
- 905409:** SPC cable (80" / 2m) for digital type
- 902011:** Spindle lifting lever for metric dial type (stroke 10mm)
- 902794:** Spindle lifting lever for digital and inch dial type (stroke .4" / 10mm)

Standard Accessories

Recommended Combinations

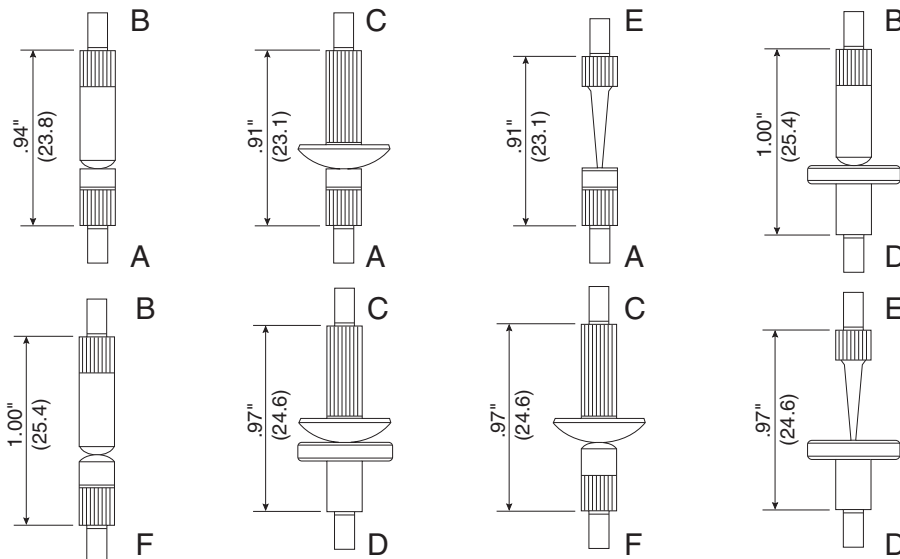

- A. 133017** Flat Point \varnothing .20
- B. 21AAA033** Shell Point .16" Radius
- C. 21BZA767** Spherical Point .36" Radius
- D. 101188** Flat Point \varnothing .50
- E. 21AAA030** Needle Point .016" Radius
- F. 21AAA032** Shell Point .16" Radius

Quick-Mini

SERIES 700

A compact comparator designed for carrying convenience, it is very suited for quick inspection of paper thickness, leather, wires, plastic parts, etc. The digital display provides error-free reading with 0.01mm / .0005" resolution.

FEATURES

- Measuring force less than 2N.
- Supplied in fitted plastic case.

Technical Data

Accuracy: Refer to the list of specifications.
 Resolution: 0.01mm or .0005"/0.01mm
 Display: LCD
 Battery: SR44 (1 pc.), **938882**
 Battery life: Approx. 2 years under normal use

Function

Zero-setting, Data hold, Power ON/OFF,
 inch/mm conversion (on inch/metric models only)



700-118-20

SPECIFICATIONS

Metric		
Range	Order No.	Accuracy
0 - 12mm	700-119-20	±0.02mm

Inch/Metric		
Range	Order No.	Accuracy
0 - .5"/0 - 12.7mm	700-118-20	±.001"



DIMENSIONS AND MASS

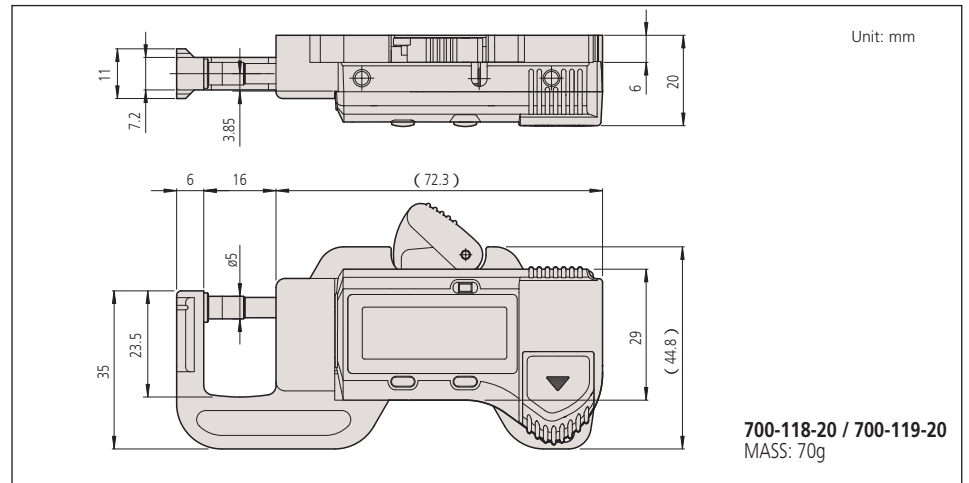

Digimatic Caliper Gages

SERIES 209 — Internal Tube Thickness Measurement Type

Versatile ID measuring gages for holes diameters, groove thickness, tube thickness, and hard-to-reach dimensions. The Digimatic

Caliper Gages provide error-free LCD readings as well as data output for SPC analysis.

Internal measurement type

209-552



SPECIFICATIONS

Inch / Metric

Range	Order No.	Resolution	Accuracy	Max. Measuring Depth L	Max. Groove Depth A	Min. Groove Width B	Type of Measuring Contact	Mass(g)
.10 - .49" / 2.5 - 12.5mm	209-550	.0002" / 0.005mm	.0008" / 0.015mm	.47" / 12mm	.027" / 0.7mm	.023" / 0.5mm	Chisel R .0039" / 0.1mm	225
.20 - .59" / 5 - 15mm	209-551	.0002" / 0.005mm	.0008" / 0.015mm	1.37" / 35mm	.09" / 2.3mm	.032" / 0.8mm	Ball .024" / 0.6mm dia.	230
.39 - 1.18" / 10 - 30mm	209-552	.0005" / 0.01mm	.0015" / 0.03mm	3.3" / 85mm	.19" / 5.2mm	.06" / 1.2mm	Ball .04" / 1mm dia.	250
.79 - 1.58" / 20 - 40mm	209-553	.0005" / 0.01mm	.0015" / 0.03mm	3.3" / 85mm	.26" / 7mm	.06" / 1.2mm	Ball .04" / 1mm dia.	250
1.18 - 1.97" / 30 - 50mm	209-554	.0005" / 0.01mm	.0015" / 0.03mm	3.3" / 85mm	.26" / 7mm	.06" / 1.2mm	Ball .04" / 1mm dia.	255
1.58 - 2.36" / 40 - 60mm	209-555	.0005" / 0.01mm	.0015" / 0.03mm	3.3" / 85mm	.31" / 8.3mm	.06" / 1.2mm	Ball .04" / 1mm dia.	265
1.97 - 2.75" / 50 - 70mm	209-556	.0005" / 0.01mm	.0015" / 0.03mm	3.3" / 85mm	.31" / 8.3mm	.06" / 1.2mm	Ball .04" / 1mm dia.	265
2.36 - 3.15" / 60 - 80mm	209-557	.0005" / 0.01mm	.0015" / 0.03mm	3.3" / 85mm	.31" / 8.3mm	.06" / 1.2mm	Ball .04" / 1mm dia.	270
2.75 - 3.54" / 70 - 90mm	209-558	.0005" / 0.01mm	.0015" / 0.03mm	3.3" / 85mm	.31" / 8.3mm	.06" / 1.2mm	Ball .04" / 1mm dia.	270
.60-2.17" / 15-55mm	209-505	.001" / 0.02mm	.002" / 0.04mm	4.49" / 115mm	.177" / 5mm	.10" / 1.8mm	Ball .059" / 1.5mm dia.	360
1.38-2.95" / 35-75mm	209-511	.001" / 0.02mm	.002" / 0.04mm	4.49" / 115mm	.315" / 8mm	.157" / 2.2mm	Ball .079" / 2.0mm dia.	380
2.17-3.74" / 55-95mm	209-513	.001" / 0.02mm	.002" / 0.04mm	4.49" / 115mm	.315" / 8mm	.157" / 2.2mm	Ball .079" / 2.0mm dia.	380
2.95-4.52" / 75-115mm	209-514	.001" / 0.02mm	.002" / 0.04mm	4.49" / 115mm	.315" / 8mm	.157" / 2.2mm	Ball .079" / 2.0mm dia.	380
3.75 - 5.32" / 95 - 135mm	209-515	.001" / 0.02mm	.002" / 0.04mm	4.49" / 115mm	.315" / 8mm	.157" / 2.2mm	Ball .079" / 2mm dia.	380
.60-2.95" / 15-75mm	209-516	.001" / 0.02mm	.003" / 0.06mm	6.89" / 175mm	.196" / 5mm	.07" / 1.8mm	Ball .059" / 1.5mm dia.	440
1.57-3.94" / 40-100mm	209-517	.001" / 0.02mm	.003" / 0.06mm	7.77" / 195mm	.315" / 8mm	.086" / 2.2mm	Ball .079" / 2.0mm dia.	440

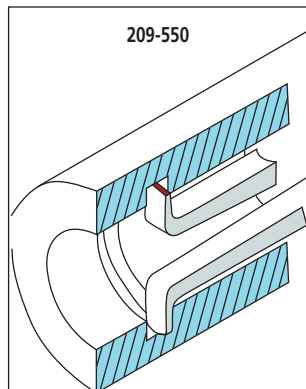

Edge R 0.1 mm

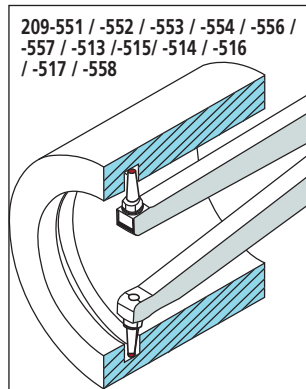

Ball ϕ 0.6mm, ϕ 1mm, ϕ 1.5mm and ϕ 2mm



Technical Data

Accuracy: Refer to the list of specifications
 Resolution: .001", .0005", or .0002" / 0.01mm, 0.02mm, or 0.005mm
 Display: LCD Analog / Digital
 Power Supply: AA Battery (1pc)
 Battery life: Approx. 350 hours
 Measuring Force: 0.7 - 1.7N
 Dust/Water protection level: IP67
 Provided with inspection certificate.

Function

Zeraset, Preset, Auto power OFF, Inch/Metric, conversion Data hold, Max/Min value holding, Data output

Optional Accessories

21JAA300D: SPC cable kit (80" / 2m) for 209-505, 209-511, 209-513, 209-514, 209-515, 209-516, 209-517

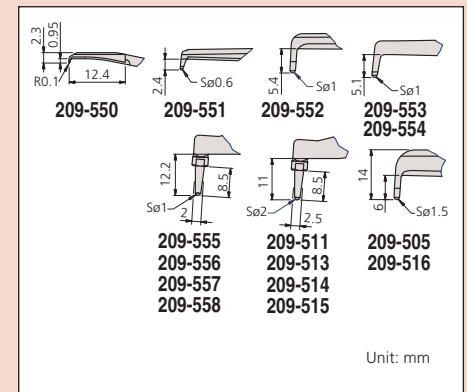

Unit: mm

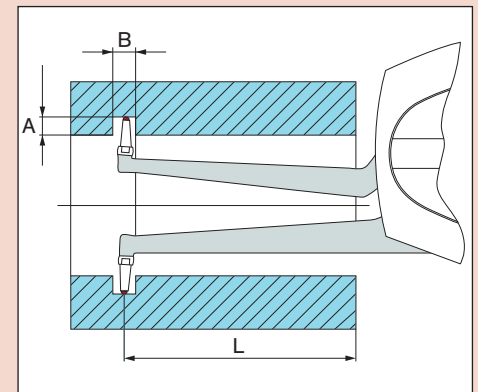



Digimatic Caliper Gages

SERIES 209 — External Tube Thickness Measurement Type

Versatile OD measuring gages for holes diameters, groove thickness, tube thickness, and hard-to-reach dimensions. The Digimatic Caliper Gages provide error-free LCD readings as well as data output for SPC analysis.



External measurement type

209-572

Technical Data

Accuracy: Refer to the list of specifications
Resolution: .001", .0005", or .0002"
0.01mm, 0.02mm, or 0.005mm
Display: Analog / Digital
Power Supply: AA Battery (1pc)
Battery life: Approx. 350 hours
Measuring Force: 0.5 - 1.5N
Dust/Water protection level: IP67
Provided with inspection certificate.

Function

Zeraset, Preset, Auto power OFF, Inch/Metric conversion, Data hold, Max/Min value holding, Data output
* Contact type 3, 4 does not have max. min. value hold.

Optional Accessories

21JAA300D: SPC cable kit (80" / 2m)

SPECIFICATIONS

Inch / Metric

Range	Order No.	Resolution	Accuracy	Max. Measuring Depth L	Measuring Contact length Hb	Measuring Contact length Hf	Type of Measuring Contact/type of set up	Mass(g)
0 - .39" / 0 - 10mm	209-570	.0002" / 0.005mm	.0008" / 0.05mm	1.37" / 35mm	.75" / 19.1mm	.73" / 18.6mm	Ball .059"/1.5mm dia. Both/ A	240
0 - .39" / 0 - 10mm	209-571	.0002" / 0.005mm	.001" / 0.02mm	1.37" / 35mm	.85" / 21.7mm	.58" / 14.8mm	Desc .24" / 6mm dia. Both/ C	175
0 - .78" / 0 - 20mm	209-572	.0005" / 0.01mm	.0015" / 0.03mm	3.2" / 85mm	.97" / 24.7mm	.97" / 24.6mm	Ball .059"/1.5mm dia. Both/ A	280
0 - .78" / 0 - 20mm	209-573	.0005" / 0.01mm	.0015" / 0.03mm	3.2" / 80mm	.97" / 24.7mm	.10" / 2.5mm	Ball .059"/1.5mm dia. Both/ B	270
0-1.57" / 0-40mm	209-531	.001" / 0.02mm	.002" / 0.04mm	4.33" / 115mm	.98" / 24.9mm	.1" / 25.4mm	Ball .118" / 3.0mm dia. Both / A	380
0-1.57" / 0-40mm	209-532	.001" / 0.02mm	.002" / 0.04mm	4.33" / 100mm	.98" / 32mm	.059" / 3.5mm	Ball .118" / 3.0mm dia. Both / B	380
0-1.57" / 0-40mm	209-533	.001" / 0.02mm	.002" / 0.04mm	4.33" / 115mm	1.14" / 30mm	.77" / 19.4mm	Desc 1.97" / 50mm dia. Both / D	380
0-2.36" / 0-60mm	209-534	.001" / 0.02mm	.003" / 0.06mm	7.48" / 190mm	.98" / 25mm	.98" / 25mm	Ball .197" / 5.0mm dia. Both / A	470
0-2.36" / 0-60mm	209-535	.001" / 0.02mm	.003" / 0.06mm	5.9" / 150mm	.98" / 25mm	.13" / 3.5mm	Ball .197" / 5.0mm dia. Both / B	470
0-2.36" / 0-60mm	209-536	.001" / 0.02mm	.004" / 0.08mm	7.48" / 190mm	1.06" / 27mm	.77" / 19.5mm	Desc 1.97" / 50mm dia. Both / D	470

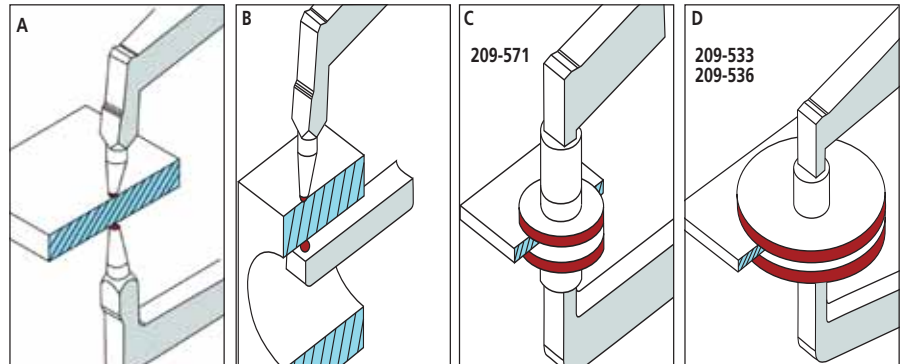
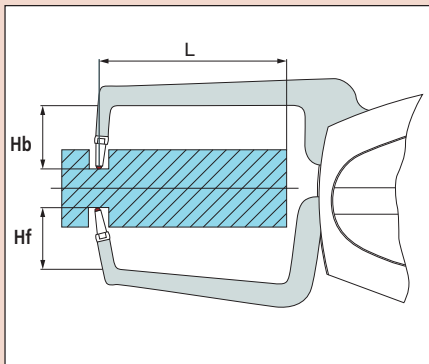
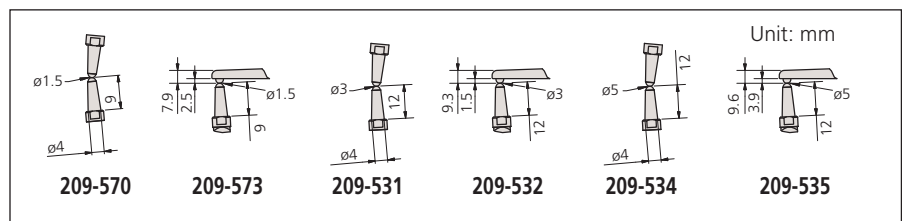

Ball ø 1.5 and 3mm for wall thickness

Ball ø 1.5 and 3mm for min. wall thickness ø3mm / 9mm

Disk ø6mm for flat surfaces

Disk ø50mm for flat surfaces



Dial Caliper Gages

SERIES 209 — Internal Measurement Type

These Dial Caliper Gages are used only as comparison gages, and should be used along with a Setting Ring or a micrometer.

The caliper is spring loaded and makes point contact at constant measuring pressure.



209-300



209-303



SPECIFICATIONS

Inch

Measuring Range	Order No.	Graduation	Accuracy	Max. Measuring Depth L	Max. Groove Depth A	Min. Groove Width B	Measuring Contact Type	Size (mm)	Mass (g)
.10 - .50"	209-350	.0002"	± .0008"	.47"	.027"	.023"	A	R0.1	200
.20 - .60"	209-351	.0002"	± .0008"	1.37"	.09"	.032"	B	ø0.6	200
.40 - 1.2"	209-352	.0005"	± .0015"	3.3"	.19"	.06"	B	ø1	200
.80 - 1.6"	209-354	.0005"	± .0015"	3.3"	.26"	.06"	B	ø1	200
1.2 - 2"	209-355	.0005"	± .0015"	3.3"	.26"	.06"	B	ø1	200
1.6 - 2.4"	209-356	.0005"	± .0015"	3.3"	.31"	.06"	B	ø1	200
2 - 2.8"	209-357	.0005"	± .0015"	3.3"	.31"	.06"	B	ø1	200
2.4 - 3.2"	209-358	.0005"	± .0015"	3.3"	.31"	.06"	B	ø1	250
2.8 - 3.6"	209-359	.0005"	± .0015"	3.3"	.31"	.06"	B	ø1	250
3.2 - 4"	209-360	.0005"	± .0015"	3.3"	.31"	.06"	B	ø1	250
2 - 4"	209-361*	.0005"	± .0015"	3.3"	.31"	.06"	C	ø1	250
3.6 - 5.6"	209-362*	.0005"	± .0015"	3.3"	.31"	.06"	C	ø1	250
5.2 - 7.2"	209-363*	.0005"	± .0015"	3.3"	.31"	.06"	C	ø1	250

*Interchangeable contact points (additional anvil 4 pcs.) with ball point .04" dia.

Metric

Measuring Range	Order No.	Graduation	Accuracy	Max. Measuring Depth L	Max. Groove Depth A	Min. Groove Width B	Measuring Contact Type	Size (mm)	Mass(g)
2.5 - 12.5mm	209-300	0.005mm	±0.015mm	12mm	0.7mm	0.5mm	A	R0.1	155
5 - 15mm	209-301	0.005mm	±0.015mm	35mm	2.3mm	0.8mm	B	ø0.6	160
10 - 30mm	209-302	0.01mm	±0.03mm	85mm	5.2mm	1.2mm	B	ø1	180
20 - 40mm	209-303	0.01mm	±0.03mm	85mm	7mm	1.2mm	B	ø1	180
30 - 50mm	209-304	0.01mm	±0.03mm	85mm	7mm	1.2mm	B	ø1	185
40 - 60mm	209-305	0.01mm	±0.03mm	85mm	8.3mm	1.2mm	B	ø1	195
50 - 70mm	209-306	0.01mm	±0.03mm	85mm	8.3mm	1.2mm	B	ø1	195
60 - 80mm	209-307	0.01mm	±0.03mm	85mm	8.3mm	1.2mm	B	ø1	200
70 - 90mm	209-308	0.01mm	±0.03mm	85mm	8.3mm	1.2mm	B	ø1	200
80 - 100mm	209-309	0.01mm	±0.03mm	85mm	8.3mm	1.2mm	B	ø1	200
50 - 100mm	209-310*	0.01mm	±0.03mm	85mm	8.3mm	1.2mm	C	ø1	220
90 - 140mm	209-311*	0.01mm	±0.03mm	85mm	8.3mm	1.2mm	C	ø1	230
130 - 180mm	209-312*	0.01mm	±0.03mm	85mm	8.3mm	1.2mm	C	ø1	240
15-65mm	209-896	0.05mm	±0.05mm	175mm	5mm	1.8mm	B	ø1.5	400
40-90mm	209-897	0.05mm	±0.05mm	175mm	8mm	2.2mm	B	ø2	440
70-120mm	209-898	0.05mm	±0.05mm	175mm	8mm	2.2mm	B	ø2	440

*Interchangeable contact point (additional anvil 5pcs.) with ball point 1mm dia

DIMENSIONS

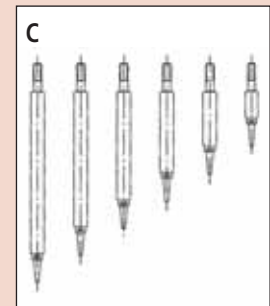
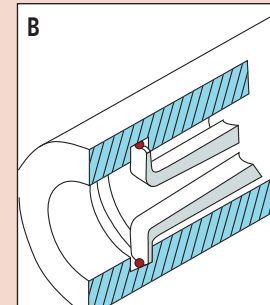
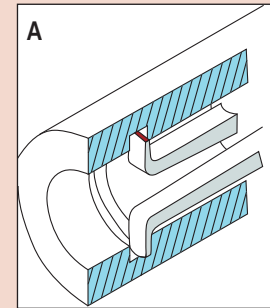
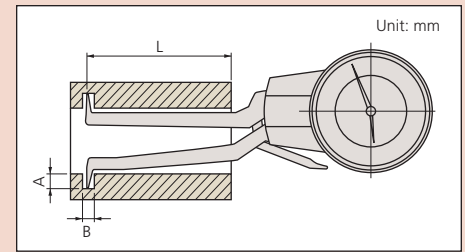

Type of Contact Points

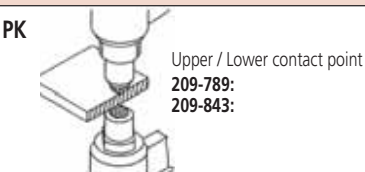
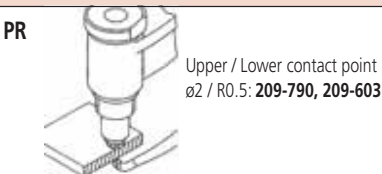
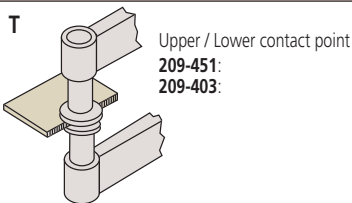
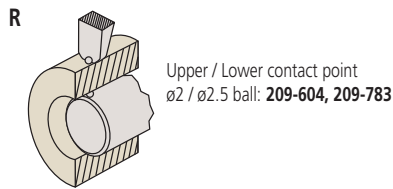
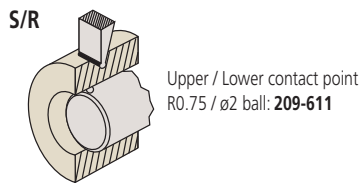
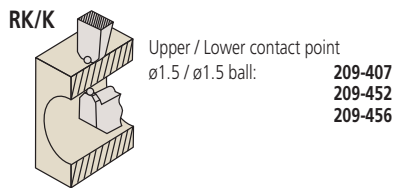
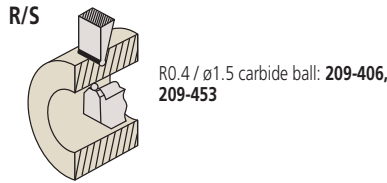
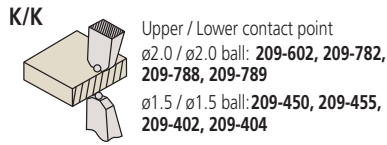
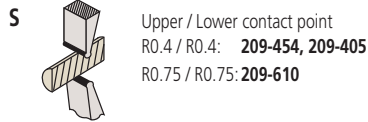

Dial Caliper Gages

SERIES 209 — External Measurement Type

IP65

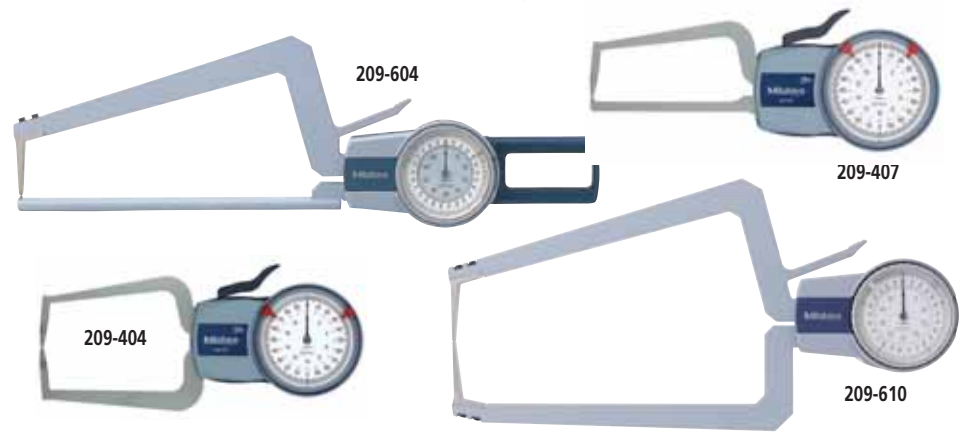

DIMENSIONS

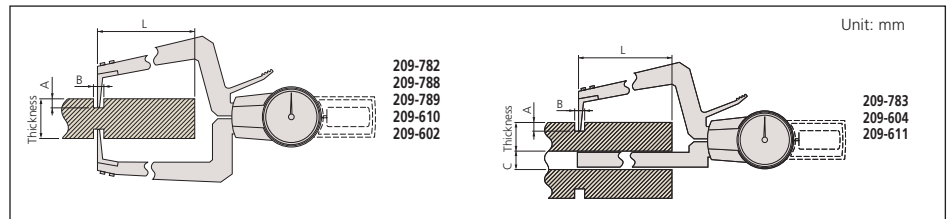

SPECIFICATIONS

Inch

Measuring Range	Order No.	Graduation	Accuracy	Max. Measuring Depth L	Max. Groove Depth A	Min. Groove Width B	Measuring Contact Type	Size (mm)	Mass (g)
0 - .40"	209-450	.0002"	± .0008"	1.37"	.75"	.75"	K/K	ø1.5	170
0 - .40"	209-451	.0002"	± .001"	1.37"	.85"	.58"	T	ø6	175
0 - .40"	209-452	.0002"	± .0008"	1.37"	.75"	.035"	RK/K	ø1.5	165
0 - .40"	209-453	.0002"	± .0008"	1.37"	.75"	.035"	R/S	Chisel R0.4, ø1.5	165
0 - .50"	209-789	.005"	± .005"	1.38"	-	-	PK	ø2, Chisel R0.5	40
0 - .50"	209-790	.005"	± .005"	1.38"	-	-	PR	ø2	40
0 - .80"	209-454	.0005"	± .0015"	3.2"	.97"	.97"	S	Chisel R0.4	210
0 - .80"	209-455	.0005"	± .0015"	3.2"	.97"	.97"	K/K	ø1.5	210
0 - .80"	209-456	.0005"	± .0015"	3.2"	.97"	.10"	RK/K	ø1.5	200
0 - .80"	209-457	.0005"	± .0015"	3.2"	.97"	.10"	R/S	Chisel R0.4, ø1.5	200
0 - 2.0"	209-782	.001"	± .002"	6.7"	1.26"	.18"	K/K	ø2	560
0 - 2.0"	209-783	.001"	± .002"	6.7"	1.26"	.18"	R	ø2.5	520
2.0 - 4.0"	209-788	.001"	± .003"	6.7"	1.26"	.18"	K/K	ø2	580

Metric

Measuring Range	Order No.	Graduation	Accuracy	Max. Measuring Depth	Max. Groove Depth	Min. Groove Width	Measuring Contact	Size (mm)	Mass (g)
0 - 10mm	209-402	0.005mm	±0.015mm	35mm	19.1mm	18.6mm	K/K	ø1.5	240
0 - 10mm	209-403	0.005mm	±0.02mm	35mm	21.7mm	14.8mm	T	ø6	175
0 - 20mm	209-404	0.01mm	±0.03mm	85mm	7mm	24.6mm	K/K	ø1.5	210
0 - 20mm	209-405	0.01mm	±0.03mm	85mm	7mm	24.6mm	S	R 0.4	210
0 - 20mm	209-406	0.01mm	±0.03mm	80mm	7mm	2.5mm	R/S	Chisel R0.4, ø1.5	200
0 - 20mm	209-407	0.01mm	±0.03mm	80mm	7mm	2.5mm	RK/K	ø1.5	200
0 - 10mm	209-843	0.1mm	±0.1mm	36mm	-	-	PK	ø2, Chisel R0.5	40
0 - 10mm	209-603	0.1mm	±0.1mm	33mm	-	-	PR	ø2	40
0 - 50mm	209-602	0.05mm	±0.05mm	170mm	10mm	4.5mm	K/K	ø2	560
0 - 50mm	209-604	0.05mm	±0.05mm	170mm	10mm	4.5mm	PR	ø2, Chisel R0.5	520
0 - 50mm	209-610	0.05mm	±0.05mm	170mm	10mm	4.5mm	R	ø2.5	560
0 - 50mm	209-611	0.05mm	±0.05mm	170mm	10mm	4.5mm	S/R	ø2, Chisel R0.75	525

Mitutoyo

Dial Caliper Gages

SERIES 209 — Internal Measurement Type

These Dial Caliper Gages are used only as comparison gages, and should be used along with a Setting Ring or a micrometer.

The caliper is spring loaded and makes point contact at constant measuring pressure.



209-122



209-152

SPECIFICATIONS

Metric

Range	Order No.	Graduation	Dial face	Accuracy	Measuring force	Dimension [L / A (max) / B (min)]		
6 - 18mm	209-122	0.01mm	0-100-100	±40µm	1.2N or less	40mm	1.0mm	2.5mm
10 - 22mm	209-123	0.01mm	0-100-100	±40µm	1.2N or less	40mm	2.0mm	2.5mm
20 - 32mm	209-124	0.01mm	0-100-100	±40µm	1.2N or less	40mm	4.2mm	2.5mm
5 - 15mm	209-152	0.01mm	0-100	±25µm	1.2N or less	30mm	2.0mm	0.7mm
10 - 20mm	209-153	0.01mm	0-100	±25µm	1.2N or less	30mm	5.0mm	0.7mm
10 - 30mm	209-171	0.01mm	0-100-100	±25µm	1.2N or less	65mm	5.2mm	0.7mm
20 - 40mm	209-172	0.01mm	0-100-100	±25µm	1.2N or less	65mm	9.5mm	0.7mm

DIMENSIONS

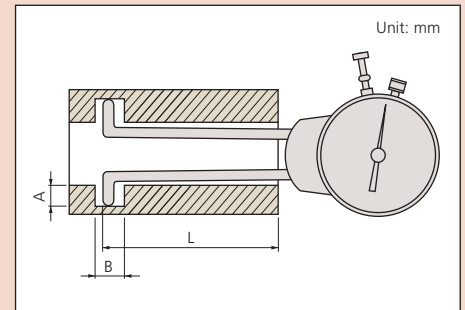

209-101

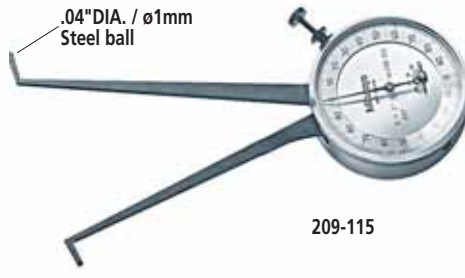

209-115

Metric

Order No.	Range	Graduation	Accuracy
209-101	10-35mm	0.025mm	±0.04mm
209-103	30-55mm	0.025mm	±0.04mm
209-105	50-75mm	0.025mm	±0.04mm

Inch

Order No.	Range	Graduation	Accuracy
209-111	.4"-1.4"	.001"	±.002"
209-113	1.2"-2.2"	.001"	±.002"
209-115	2.0"-3.0"	.001"	±.002"

Technical Data

Dial Diameter: 2" / 51mm

DIMENSIONS

Range	A	B	C	D
10 - 35mm / .4 - 1.4"	4.8mm	2.3mm	4.8mm	2.3mm
30 - 55mm / 1.2 - 2.2"	6.8mm	4.3mm	17.0mm	14.5mm
50 - 75mm / 2.0 - 3.0"	10.0mm	7.6mm	11.5mm	9.8mm

Contact Point Dimensions

Application

Measuring contact force of relay



DIMENSIONS

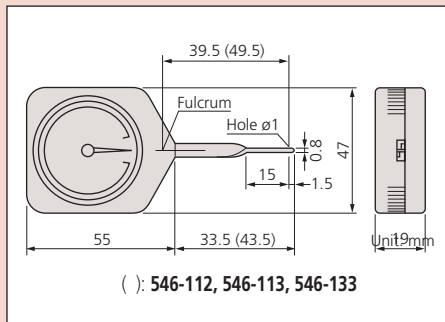

DIMENSIONS

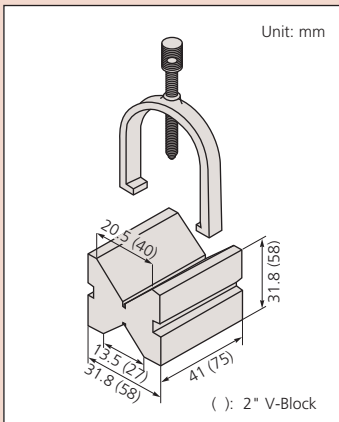

DIMENSIONS

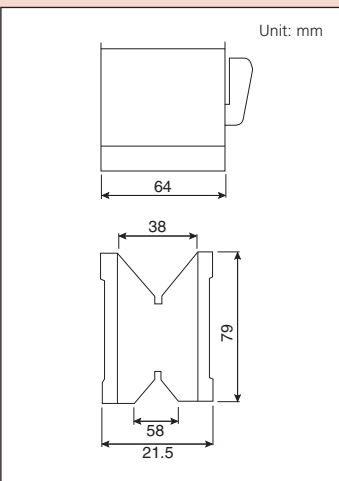

Dial Tension Gages

SERIES 546

FEATURES

- Can measure dynamic tension in Newton (N) units.
- Dial Tension Gages are widely used to determine the contact force of other measuring instruments as well as that of electrical relays, micro-switches, valves and precision springs.
- Convenient peak-hold type gages are also available.



SPECIFICATIONS

Standard		
Range	Order No.	Minimum reading
6mN - 50mN	546-112	2mN
10mN - 100mN	546-113	5mN
30mN - 300mN	546-114	10mN
0.06N - 0.5N	546-115	0.02N
0.1N - 1N	546-116	0.05N
0.15N - 1.5N	546-117	0.05N
0.3N - 3N	546-118	0.1N
0.6N - 5N	546-119	0.2N

Peak hold		
Range	Order No.	Graduation
10mN - 100mN	546-133	5mN
30mN - 300mN	546-134	10mN
0.06N - 0.5N	546-135	0.02N
0.1N - 1N	546-136	0.05N
0.15N - 1.5N	546-137	0.05N
0.3N - 3N	546-138	0.1N
0.6N - 5N	546-139	0.2N

V-Block Sets

SERIES 181

FEATURES

- Two V-blocks per set.
- Magnetic type is available. (The magnetic type V-block is not provided with a workpiece clamp.)



SPECIFICATIONS

Metric		
Max. workpiece dia.	Order No.	Remarks
25mm	181-902	With clamp

Inch		
Max. workpiece dia.	Order No.	Remarks
1"	181-901	With clamp
2"	181-904	With clamp

Magnetic V-Block

SERIES 181

SPECIFICATIONS

Metric			
Max. workpiece dia.	Order No.	Magnetic Pull	Remarks
2"	181-146	60 kg	1 Piece



Dial Snap Gages

SERIES 201

FEATURES

- Designed for quick GO/NG judgment of diameters of cylinders and shafts in machining processes.
- Dial indicator is optional.
- Anvil retracting stroke: .078" / 2mm
- Anvil positioning range: 1" / 25mm
- Wide (.53 x .47" / 13.5 x 12mm), flat carbide anvils.
- Both front edges of the anvil are chamfered for easy insertion.

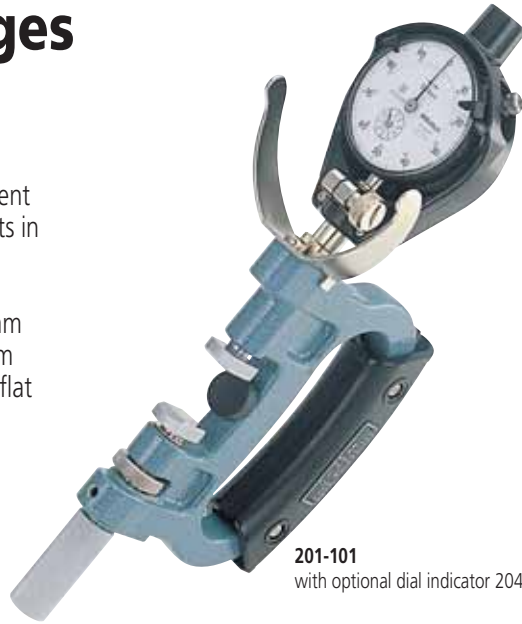

201-101
with optional dial indicator 2046SB.

SPECIFICATIONS

Metric — Gage stem diameter 8mm

Range	Order No.	Parallelism	Measuring force	Recommended dial indicator (optional)
0 - 25mm	201-101	5µm or less	15N±3N	2046SB (0.01mm reading), 2109SB-10 (0.001mm reading)
25 - 50mm	201-102	5µm or less	15N±3N	2046SB (0.01mm reading), 2109SB-10 (0.001mm reading)
50 - 75mm	201-103	5µm or less	15N±3N	2046SB (0.01mm reading), 2109SB-10 (0.001mm reading)
75 - 100mm	201-104	5µm or less	15N±3N	2046SB (0.01mm reading), 2109SB-10 (0.001mm reading)
100 - 125mm	201-105	5µm or less	15N±3N	2046SB (0.01mm reading), 2109SB-10 (0.001mm reading)
125 - 150mm	201-106	5µm or less	15N±3N	2046SB (0.01mm reading), 2109SB-10 (0.001mm reading)
150 - 175mm	201-107	5µm or less	15N±3N	2046SB (0.01mm reading), 2109SB-10 (0.001mm reading)
175 - 200mm	201-108	5µm or less	15N±3N	2046SB (0.01mm reading), 2109SB-10 (0.001mm reading)
200 - 225mm	201-109	5µm or less	15N±3N	2046SB (0.01mm reading), 2109SB-10 (0.001mm reading)
225 - 250mm	201-110	5µm or less	15N±3N	2046SB (0.01mm reading), 2109SB-10 (0.001mm reading)
250 - 275mm	201-111	5µm or less	15N±3N	2046SB (0.01mm reading), 2109SB-10 (0.001mm reading)
275 - 300mm	201-112	5µm or less	15N±3N	2046SB (0.01mm reading), 2109SB-10 (0.001mm reading)

Inch — Gage stem diameter 3/8"

Range	Order No.	Parallelism	Measuring force	Recommended dial indicator (optional)
0 - 1"	201-151	.00025" or less	15N±3N	2803SB-10 (.0001" reading)
1 - 2"	201-152	.00025" or less	15N±3N	2803SB-10 (.0001" reading)
2 - 3"	201-153	.00025" or less	15N±3N	2803SB-10 (.0001" reading)
3 - 4"	201-154	.00025" or less	15N±3N	2803SB-10 (.0001" reading)
4 - 5"	201-155	.00025" or less	15N±3N	2803SB-10 (.0001" reading)
5 - 6"	201-156	.00025" or less	15N±3N	2803SB-10 (.0001" reading)
6 - 7"	201-157	.00025" or less	15N±3N	2803SB-10 (.0001" reading)
7 - 8"	201-158	.00025" or less	15N±3N	2803SB-10 (.0001" reading)
8 - 9"	201-159	.00025" or less	15N±3N	2803SB-10 (.0001" reading)
9 - 10"	201-160	.00025" or less	15N±3N	2803SB-10 (.0001" reading)
10 - 11"	201-161	.00025" or less	15N±3N	2803SB-10 (.0001" reading)
11 - 12"	201-162	.00025" or less	15N±3N	2803SB-10 (.0001" reading)

DIMENSIONS

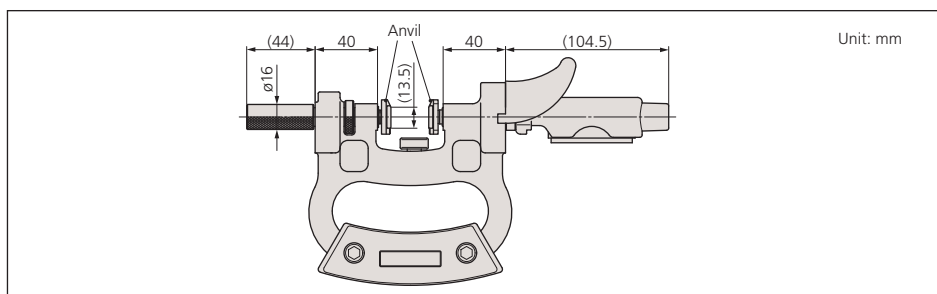

Technical Data

Accuracy: Refer to the list of specifications
 Anvil retracting stroke: .078" / 2mm
 Anvil positioning range: 1" / 25mm
 Anvil flatness: .00004" / 1µm

Dial/Digimatic Indicator & Magnetic Stand Sets

SERIES 950, 7



Set No. 950-723



Set No. 950-705



Set No. 950-707



Set No. 950-728



7046

DIMENSIONS

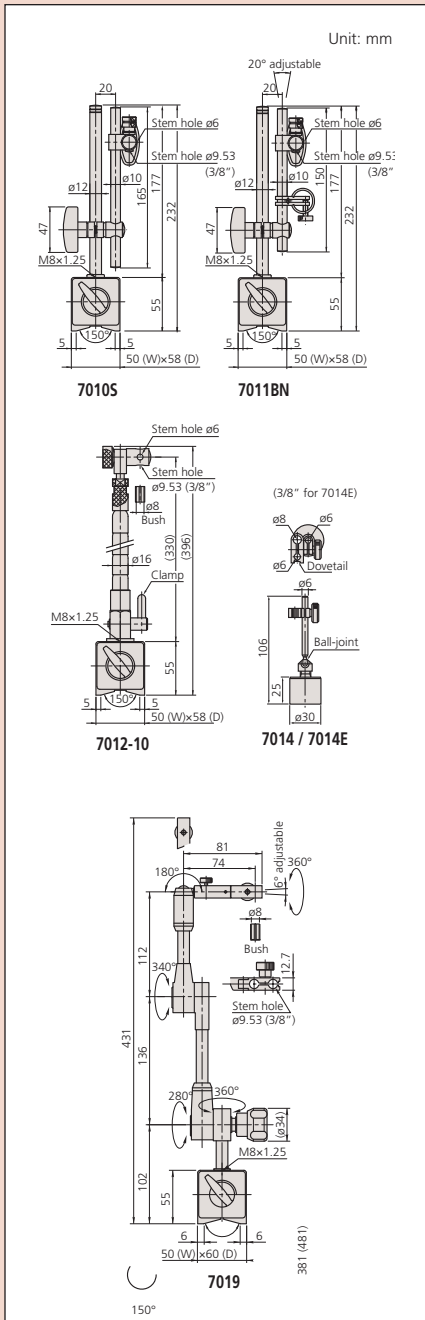

SPECIFICATIONS

Indicator Stand	IDS (543-683B) Digimatic Indicator	IDC (543-392B) Digimatic Indicator	2804S-10 Dial Indicator	2915S-10 Dial Indicator	2416S Dial Indicator
7010S Magnetic Stand	Set No. 950-720	Set No. 950-721	Set No. 7045	Set No. 950-700	Set No. 7046
7011BN Magnetic Stand	Set No. 950-722	Set No. 950-723	Set No. 950-702	Set No. 950-703	Set No. 950-701
7012 Magnetic Flexi-Stand	Set No. 950-724	Set No. 950-725	Set No. 950-705	Set No. 950-706	Set No. 950-704
7019 Universal Stand	Set No. 950-726	Set No. 950-727	Set No. 950-708	Set No. 950-709	Set No. 950-707
7003 Serrated Anvil Stand	Set No. 950-728	Set No. 950-729	Set No. 950-711	Set No. 950-712	Set No. 950-710
7004 Flat Anvil Stand	Set No. 950-730	Set No. 950-731	Set No. 950-714	Set No. 950-715	Set No. 950-713

Magnetic Stands

SERIES 7

Mitutoyo's Magnetic Stands accept all dial indicators and dial test indicators. The ON-OFF switch offers instant mounting and dismounting without any adverse effect to the indicators or workpiece surface.

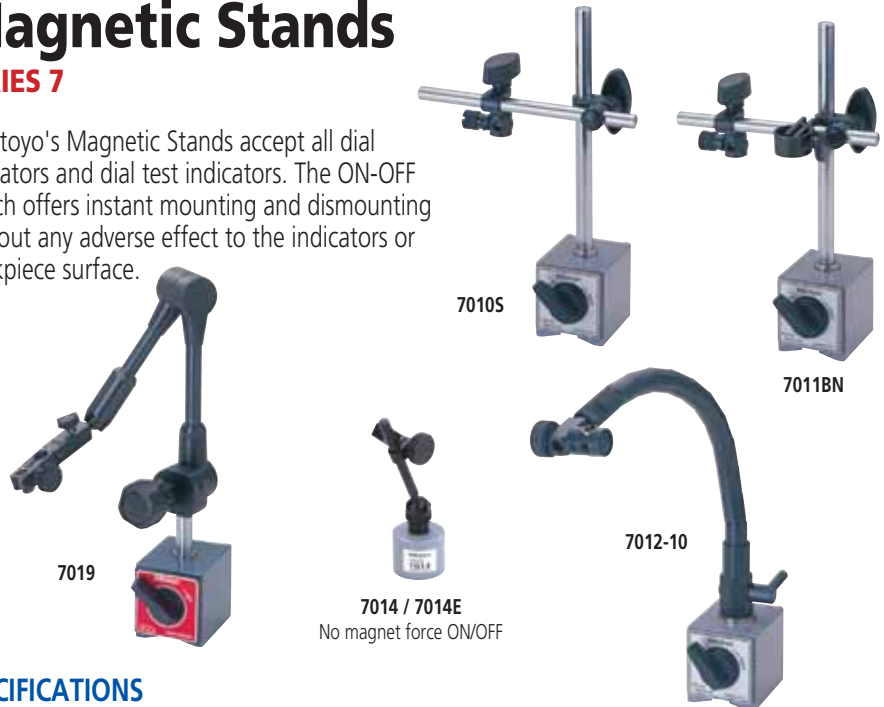

SPECIFICATIONS

Order No.	Description	Applicable holding stem dia.	Dovetail groove	Remarks
7010S	Magnetic stand	$\phi 6$ mm, $\phi 8$ mm*, $\phi 9.53$ mm (3/8")	—	—
7011BN	Magnetic stand	$\phi 6$ mm, $\phi 8$ mm*, $\phi 9.53$ mm (3/8")	—	With fine adjustment
7012-10	Magnetic flexi-stand	$\phi 6$ mm, $\phi 8$ mm*, $\phi 9.53$ mm (3/8")	—	For dial test indicator
7014	Mini magnetic stand	$\phi 6$ mm, $\phi 8$ mm	Provided	Without magnet ON/OFF
7014E	Mini magnetic stand	$\phi 6$ mm, $\phi 8$ mm*, $\phi 9.53$ mm (3/8")	Provided	Without magnet ON/OFF
7019	Universal magnetic stand	$\phi 8$ mm*, $\phi 9.53$ mm (3/8")	Provided	With hydraulic position lock

*Supplied with collar 02AZC291

Mitutoyo

Dial Gage Stands

SERIES 7

The Dial Gage Stands are designed for comparison measurements of height using a dial indicator or Digimatic Indicator.

FEATURES

- Vertical travel of the gage holder — Dial Gage Stand: 100mm, Transfer Stand: 335mm
- Fine-adjustment of 1mm available for zero-setting of the indicator.
- With an interchangeable anvil. Domed anvil (**101463**) is optional.



7001-10
with ø58mm serrated anvil



7002-10
with ø58mm flat anvil

SPECIFICATIONS

Inch			
Order No.	Stem hole	Remarks	Mass (kg)
7001-10	3/8" DIA	with serrated anvil (101462)	3.95
7002-10	3/8" DIA	with flat anvil (101461)	3.95

DIMENSIONS

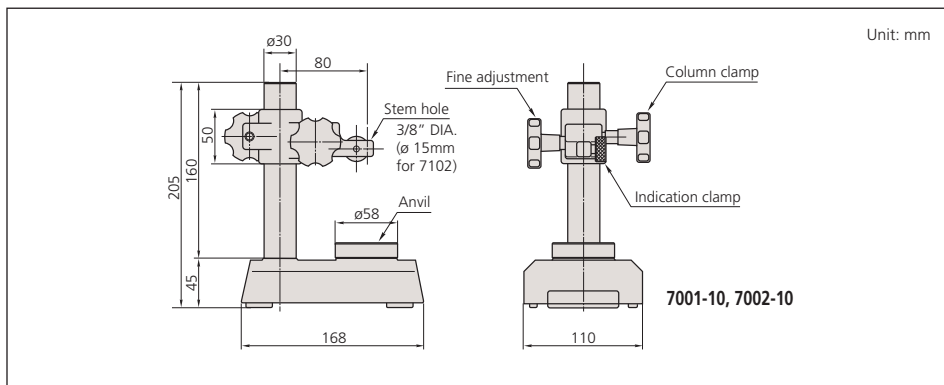

Optional Accessories

- 02AZC291:** Stem Collar OD 3/8", ID 8mm
(For **7001-10, 7002-10**)
- 101462:** Hardened steel serrated anvil (flatness: 1µm)
- 101463:** Hardened steel domed anvil
- 101461:** Hardened steel flat anvil (flatness: 1µm)

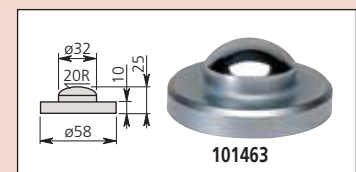
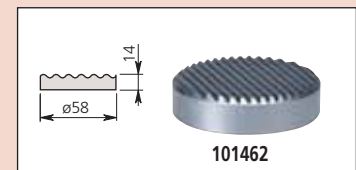
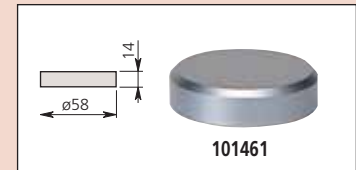



519-109E

Optional Accessories

- 101461:** Hardened steel flat anvil (flatness: 1µm)
- 101463:** Hardened steel domed anvil
- 390070:** Dovetail attachment used with test indicators
- 58ZAA016:** Fine feed bracket assembly (standard)

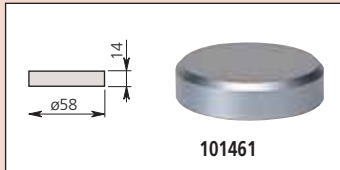

101461

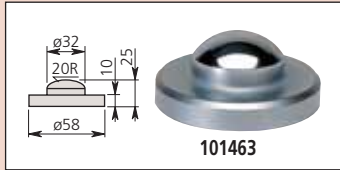

101463



390070

Transfer Stand

SERIES 519

The Transfer Stands are designed for comparison measurements of height using a dial indicator or Digimatic Indicator.

SPECIFICATIONS

Order No.	Stem hole	Remarks
519-109E	3/8" DIA	with serrated anvil (101462)

FEATURES

- Vertical travel of the gage holder — Dial Gage Stand: 100mm, Transfer Stand: 335mm
- Fine-adjustment of 1mm available for zero-setting of the indicator.
- With an interchangeable anvil. Domed anvil (**101463**) and Flat anvil (**101461**) are optional.

DIMENSIONS AND MASS

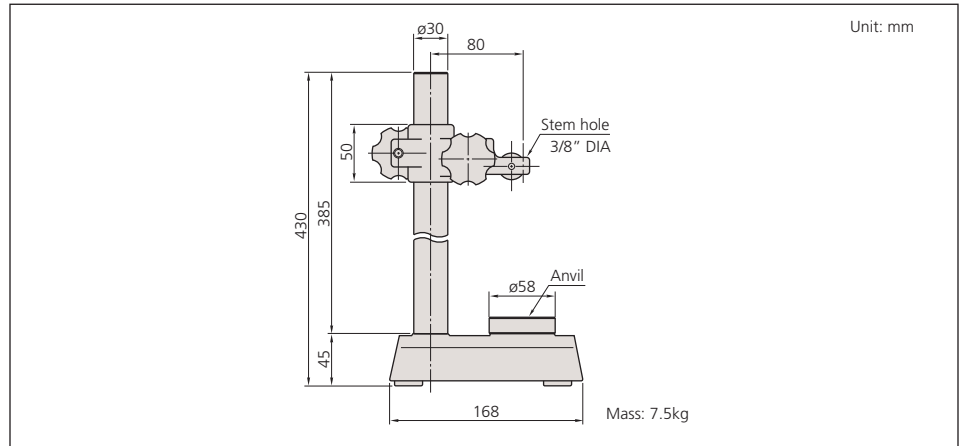

Roll Caliper

SERIES 310

FEATURES

- The Roll Caliper is the most widely used instrument for checking the diameter of rollers used in the manufacture of many products such as metal, rubber and paper.
- Performs fast and accurate comparison measurements of roller diameter with the roller still mounted on a machine tool.
- Various types of detectors (dial indicator,

Digimatic indicator, Mu-Checker gage head, etc.) can be attached according to the required accuracy and workpiece size.

SPECIFICATIONS

Inch	
Range	Order No.
ø20" - ø56"	310-141
ø16" - ø42"	310-142
ø11" - ø32"	310-143
ø8" - ø24"	310-144
ø4" - ø17"	310-145



310-142
with optional dial indicator

Precision Granite Stands (with black granite bases)

SERIES 517

Mitutoyo's Granite Comparator Stands are basic building-blocks for the assembly of special-purpose, precision measuring equipment. By mounting precision measuring instruments such as Digimatic indicators, Mu-Checker Cartridge Heads, and Linear Gages onto the stands, it is possible to satisfy all manner of measuring assignment. The rigid granite base is free from burrs, pileups, rust, and deterioration over time.

517-895
(stand only)



517-898
(stand only)

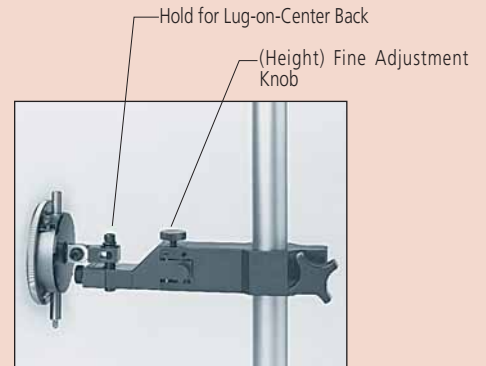

SPECIFICATIONS

Order No.	Base	Column Diameter	Column Height	Throat Clearance	Table Flatness	Table Thickness	Weight
517-890	6 x 8"	1.181"	6"	4.375"	.0001"	2"	18 lbs
517-891	6 x 8"	1.181"	8"	4.375"	.0001"	2"	19 lbs
517-892	6 x 8"	1.181"	12"	4.375"	.0001"	2"	20 lbs
517-893	6 x 8"	1.181"	18"	4.375"	.0001"	2"	21 lbs
517-895	8 x 12"	1.181"	6"	5.8"	.0001"	2"	29 lbs
517-896	8 x 12"	1.181"	8"	5.8"	.0001"	2"	30 lbs
517-897	8 x 12"	1.181"	12"	5.8"	.0001"	2"	31 lbs
517-898	8 x 12"	1.181"	18"	5.8"	.0001"	2"	32 lbs
517-899	8 x 12"	1.181"	24"	5.8"	.0001"	2"	35 lbs

Optional Accessories

58AAA151: ø8mm bush*
 58AAA273: ø9.53mm (3/8") bush*
 58AAA276: ø15mm bush*
 *Only available for 215-156.

Comparator Stands

SERIES 215

The Comparator Stands consists of a very stable, cast-iron base and an upright column with a mounting bracket that features fine

adjustment. The grid type anvil prevents the workpiece from sticking to it.

SPECIFICATIONS

Order No.	Square anvil size (W x D)	Column travel	Stem hole	Mass (kg)	Remarks
215-514	150 x 150mm	250mm / 10"	.375"	22.5	With fine adjustment over the entire travel
215-515	150 x 150mm	250mm / 10"	.375" / .787"	23.0	With fine adjustment over the entire travel

DIMENSIONS

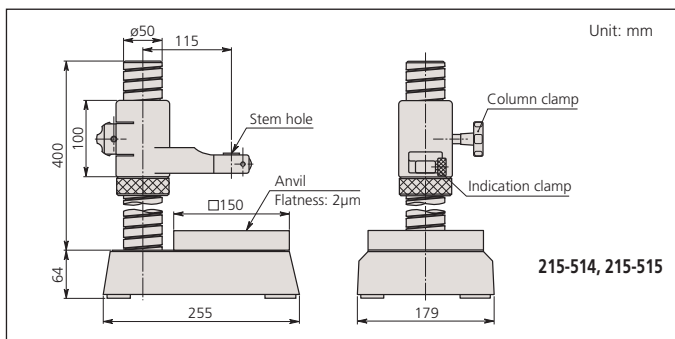

215-514

Optional Accessories

58AAA151: ø8mm bush*
 58AAA273: ø9.53mm (3/8") bush*
 58AAA276: ø15mm bush*
 *Only available for 215-515.