

Linear Encoder NC Linear Scale Systems

Catalog No. E13005



Linear Encoders for
Numerical Motion/Position Control System

Mitutoyo



Integrated Production System for...

The Utsunomiya Operations Kiyohara Production Department presents a complete manufacturing environment where linear encoders for Mitutoyo measuring equipment as well as linear scales for the general market are produced. The whole production process including the manufacturing of glass scales for linear encoders, assembly of electronic components and products, and inspection is performed here. Conditions are continuously being optimized for further enhanced scale accuracy and even higher quality. The underground research laboratory at the Kiyohara Production Department has been specially designed and constructed to provide the environment required for the high-level scale graduation process as well as for high-accuracy measurements.

Located on a solid bedrock foundation nine meters underground, the facility maintains a stable and tightly controlled environment all year round. Temperature and humidity fluctuations as well as external vibrations are kept to an absolute minimum. In this laboratory, we produce master scales, perform accuracy evaluation, and pursue various kinds of research that provide the underpinning for the accuracy and quality of our linear scales.



Sputtering equipment

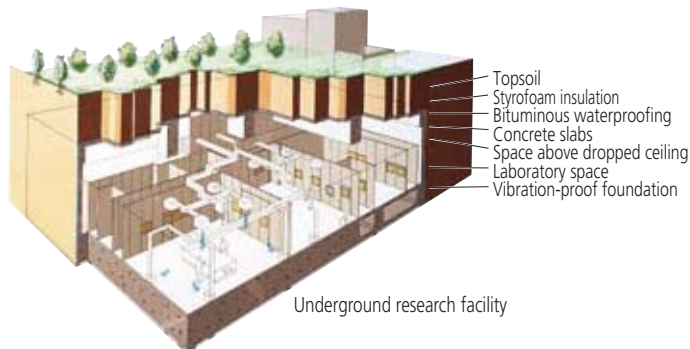

Underground research facility

Linear Encoder Accuracy Calibration Technology

To assure high accuracy in linear encoders, a highly reliable calibration system is indispensable. The ultra-precision length measuring machine developed by Mitutoyo and installed in the underground research facility at the Kiyohara Production Department benefits from the highly stable underground environment. In addition, the light path of the laser interferometer used to measure lengths is placed in a vacuum to further eliminate any causes of uncertainty. The result is a linear encoder calibration system of world-leading precision, internationally recognized by mutual interlaboratory comparisons. In recognition of the high technological standard realized by this system, it received the Best Paper Award of the Japan Society of Precision Engineering in 2004 and the FA Paper Award of the FANUC FA and Robot Foundation in 2005.



Ultra-precision length measuring machine with vacuum laser interferometer

Mitutoyo

NC Linear Scale Systems

Detection Principle	3, 4	Interface Unit	
Applications	5, 6	PSU-200	41, 42
NC Linear Scale Systems – System Diagram	7	PSU-250	43, 44
NC Linear Scale Systems – Overview	8	Absolute Scale Unit	45, 46
Separate Type ST Series		ABS ST700 Compact Type Series	47–52
ST36	9–12	ABS AT500 Series (0.005μm)	53–60
ST24	13–16	ABS AT500 Series (0.05μm)	61–68
ST46-EZA	17–20	ABS AT500E Series	69–76
ST422	21, 22	ABS AT300 Series	77–80
Assembly Type AT Series		Discontinued models and succession models	81
AT100	23–26	specification compatibility tables	82, 83
AT402E	27–30	Handling linear scales	84–86
AT211	31–36	Technical Information	
AT203	37–40		

Linear Scale is a registered trademark of Mitutoyo Corporation for its linear encoder products.

Linear Scales from Mitutoyo are traceable to national standards

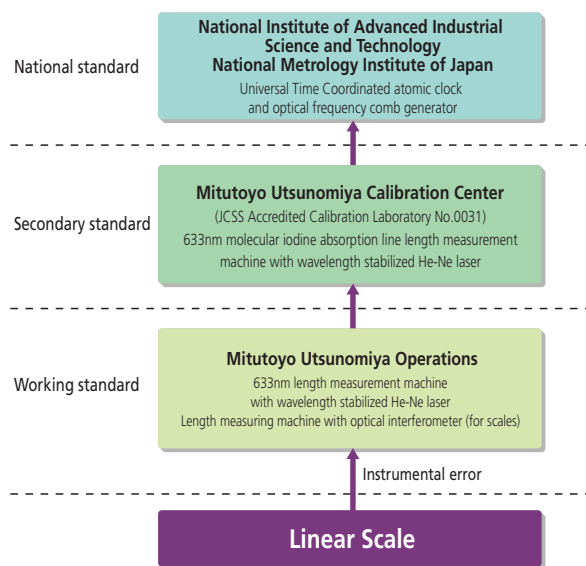

Linear Scale Traceability System Chart

Detection Principle

Detection principle of the transmission photoelectric scale (Assembly Type Linear Scale)

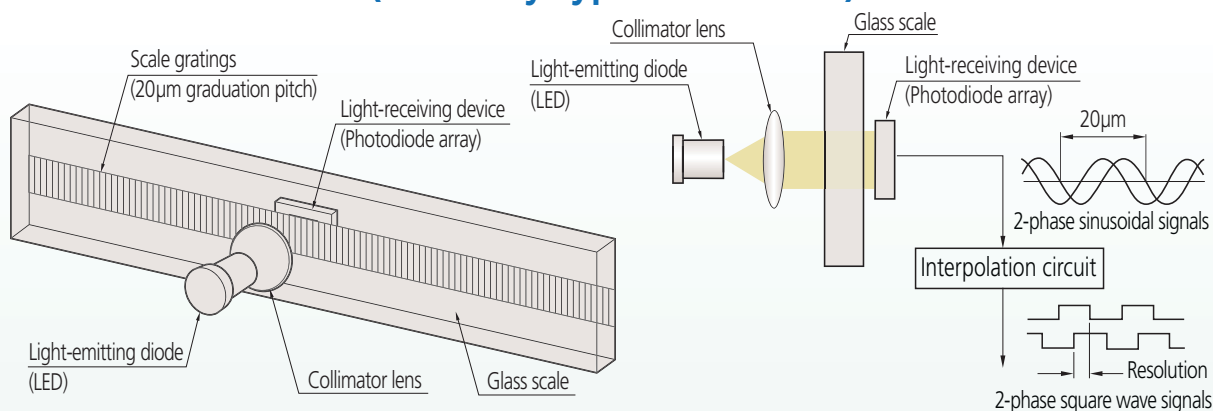

The assembly type linear scale uses a graduated glass scale as measuring length reference. A light-emitting diode (LED) and light-receiving device mounted on opposite sides of the scale serve to detect and detect changes in light intensity and output a value representing the displacement magnitude. Because the change in transmitted light intensity of the glass scale is converted into an electrical signal, the setup is called a transmission photoelectric system. A parallel light beam generated by the LED and collimator lens is directed through the scale gratings. A light-receiving device consisting of a photodiode array on the other side of the scale receives the parallel light beam and produces interference fringes with a cycle that corresponds to the scale grating pitch. When the glass scale is displaced in the measuring direction, the interference fringes shift, and a 2-phase sinusoidal signal with a cycle that corresponds to the 20µm pitch of the scale gratings is output by the light-receiving device. An interpolation circuit electrically divides the output sinusoidal signal, resulting in a square wave (pulse) signal representing the limiting resolution.

Detection principle of the reflective photoelectric scale (ST36, etc.)

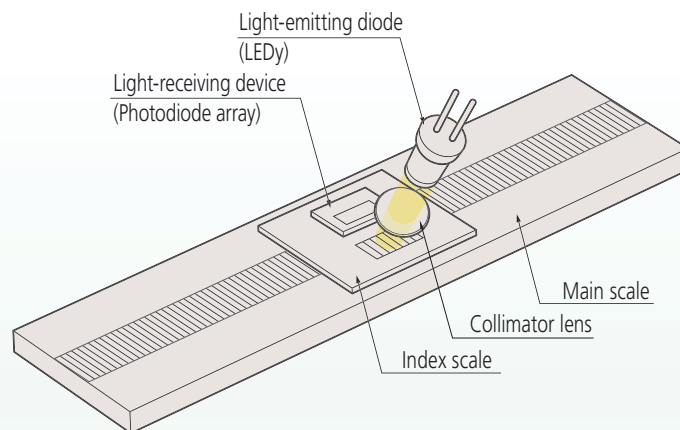

The separate type photoelectric linear scale also uses a graduated glass scale as measuring length reference. An LED and light-receiving device together with gratings on an index scale produce and detect changes in light intensity and output a value representing the displacement magnitude. Because the change in reflected light intensity of the glass scale is converted into an electrical signal, the setup is called a reflective type photoelectric system. A parallel light beam generated by the LED and collimator lens is directed onto the index scale gratings and the glass scale gratings. The light reflected from the scale gratings produces interference fringes on the photodiode array of the light-receiving device. When the glass scale is displaced in the measuring direction, the interference fringes shift, and a sinusoidal signal with a cycle that is the same as, or one-half of, the scale grating pitch is output by the light-receiving device.

Detection principle of electromagnetic induction system (ABS ST700)

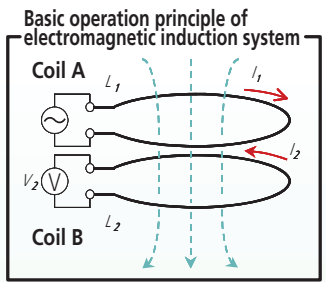

[Figure 1] Electromagnetic induction system encoder principle

When a current (I_1) that changes over time is passed through coil A, a magnetic flux is created in the vicinity of coil A. This causes an inductive current (I_2) to flow in coil B, in a direction that cancels out the magnetic field.

Magnetic permeability between coils is largely identical in air, water, or oil.

Electromagnetic induction type sensor has excellent water resistance and oil resistance.

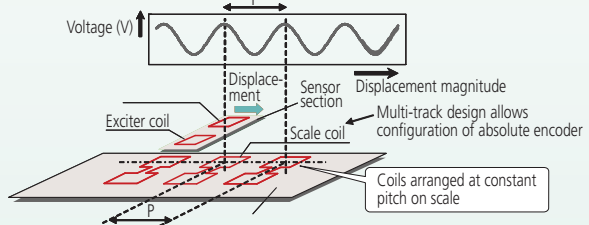

[Figure 2] Electromagnetic induction scale detection principle

Electromagnetic induction is a phenomenon that occurs, for example, when two coils are arranged facing each other, as shown in Figure 1, and a time-varying current (I_1) is passed through coil A. This will cause an induced current (I_2) to flow in coil B, in a direction that cancels out the magnetic field. The electromagnetic induction type linear scale uses this phenomenon to convert a displacement magnitude into an electrical signal. The operational principle of the sensor section is shown in Figure 2. A number of scale coils are arranged with precise spacing on the main scale. The moveable sensor section that detects displacement carries an exciter coil and a corresponding detector coil. A current is sent through the exciter coil, thereby creating a magnetic flux that induces a current in the facing scale coil. The magnetic flux created in turn by that current induces a current in the facing detector coil. The degree of inductive coupling between the coils changes according to the displacement magnitude of the sensor section, allowing a sinusoidal signal with a cycle that corresponds to the pitch of the scale coils to be obtained. By using an electrical circuit that performs interpolation (division) of this sinusoidal signal, displacement can be measured with fine resolution.

Applications

Semiconductor fabrication equipment

Dicing saw positioning

AT Series - Reference

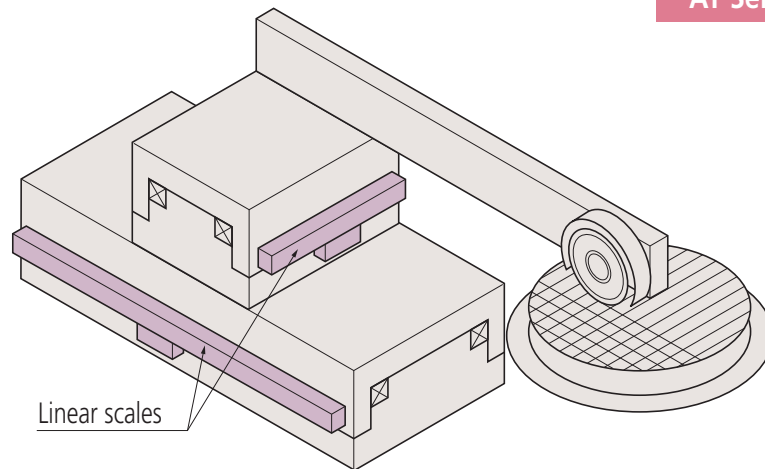

Lithography equipment

Scanning stage positioning

ST Series - Reference

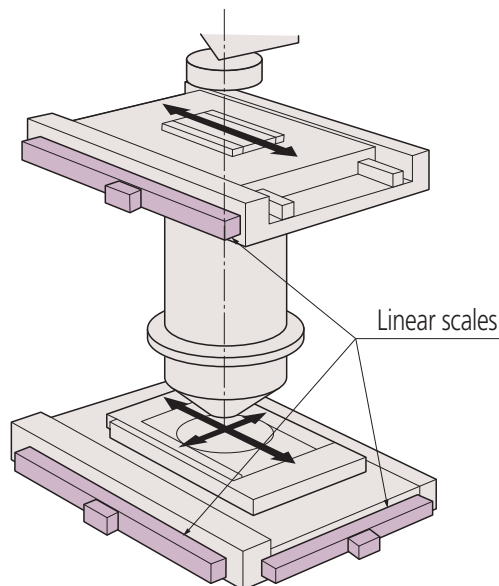

Electron microscope

Mask observation, circuit pattern measurement, defect inspection, etc.

ST Series - Reference

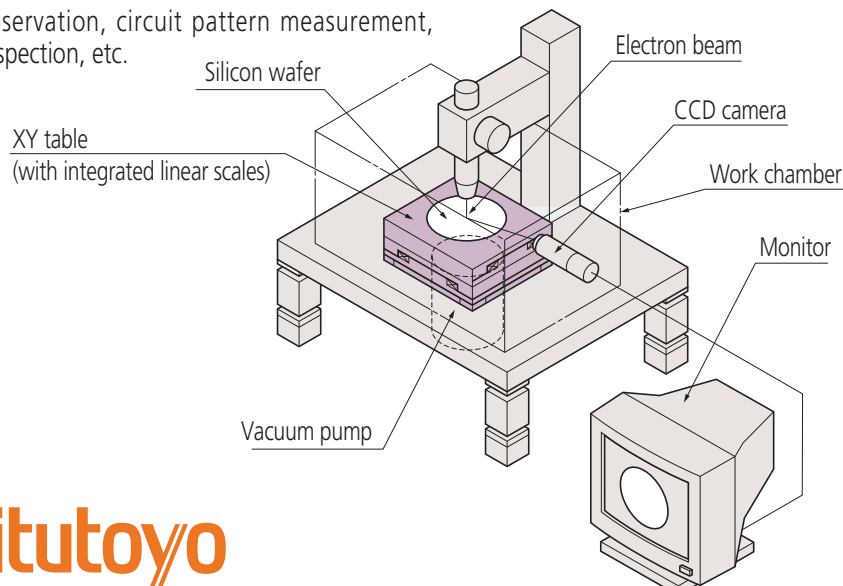

Various NC machine tools

High-precision fully closed loop control

AT Series - Reference

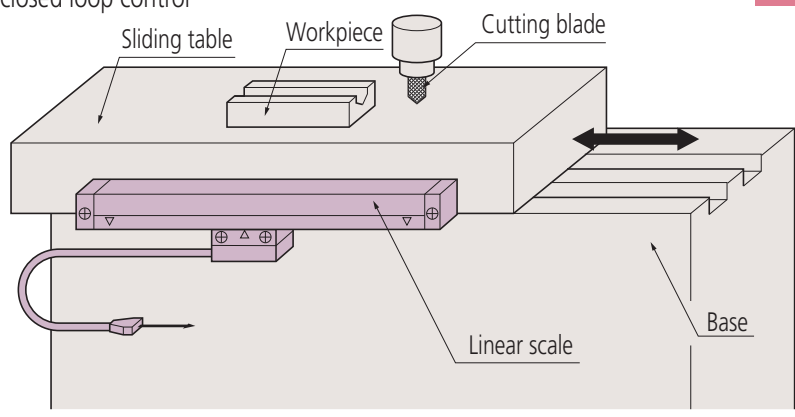

Electronic component inserter

High-speed, high-precision mounting of electronic components

ST Series - Reference

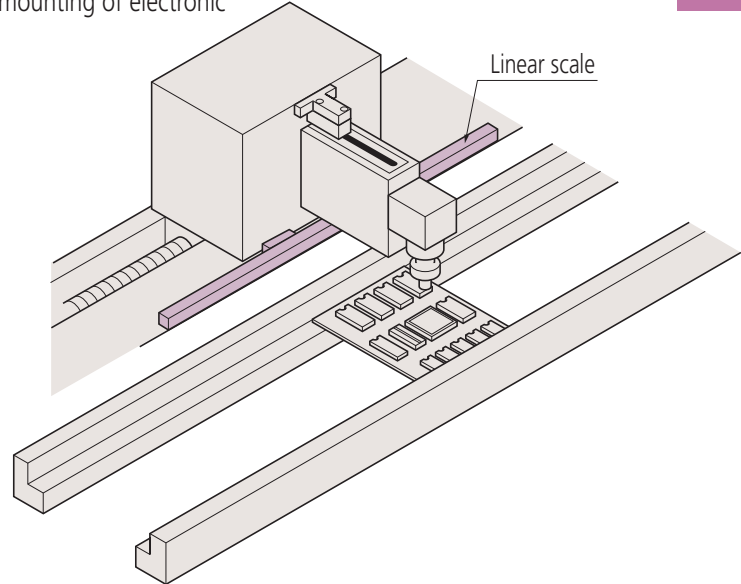

FPD inspection equipment

Defect inspection and repair position determination

ST Series - Reference

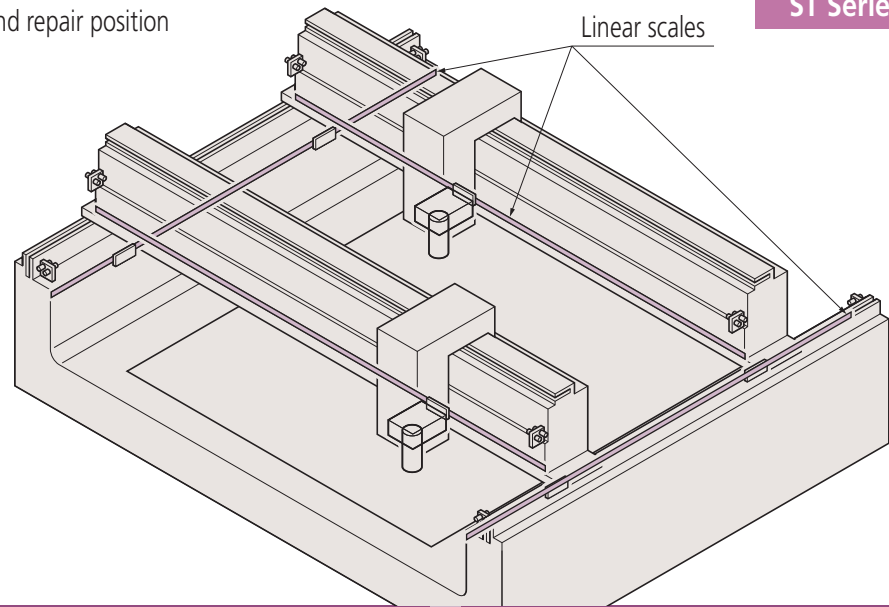

NC Linear Scale Systems – System Diagram

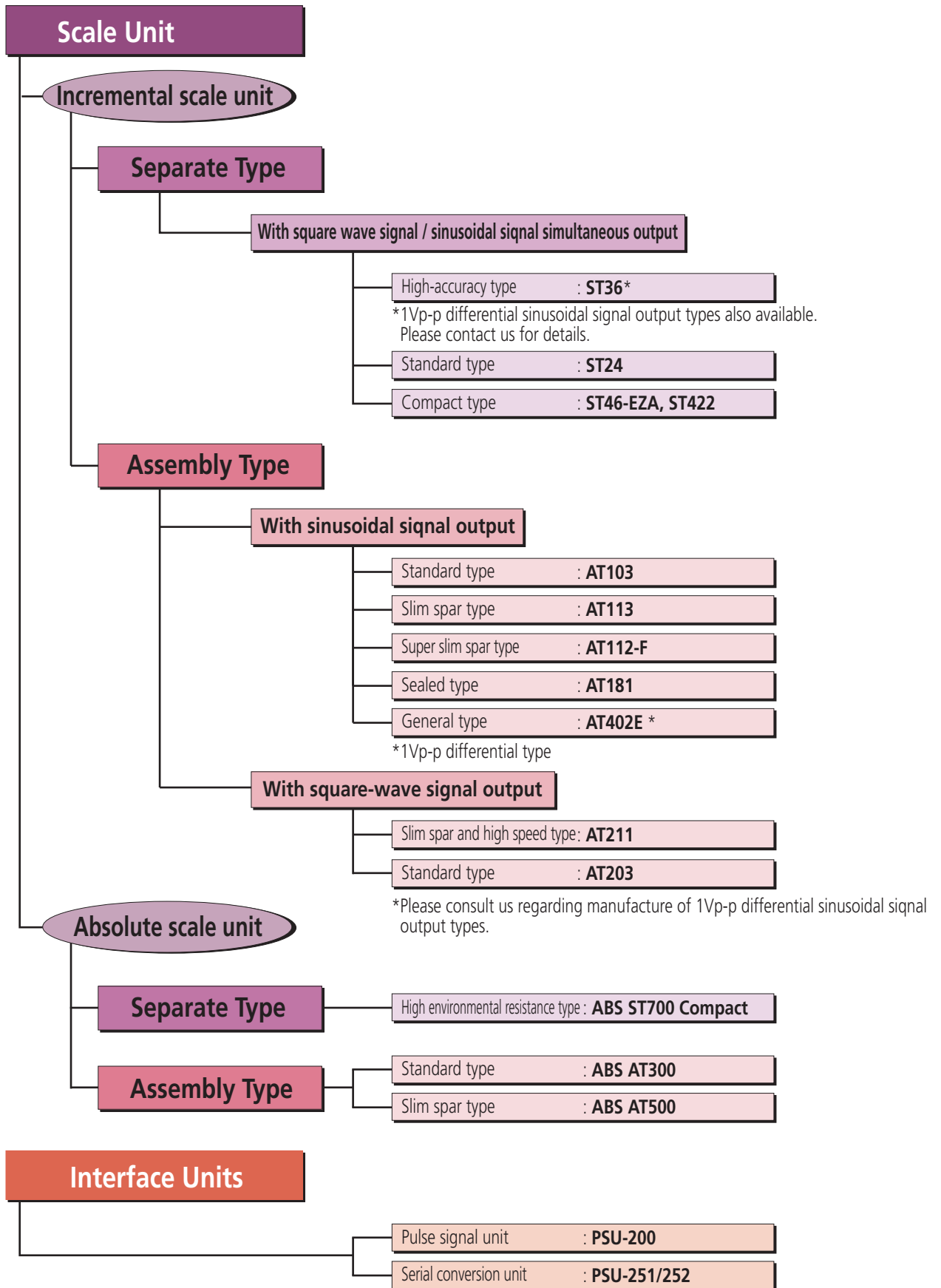

NC Linear Scale Systems – Overview

	Scale name (Code)	Reference point	Absolute function	Main scale grating pitch	Signal output pitch	Signal unit	No. of divisions	Resolution	Maximum response speed*1	Minimum edge interval*2	See page
Separate Type Linear Scales	ST36B ST36C (ST36A) (ST36D)	○	×	8μm	4μm	– (PSU-200)	400	0.01μm	70mm/s	125ns	P9 - 12
							200	0.02μm	150mm/s		
							80	0.05μm	260mm/s		
							40	0.1μm	720mm/s		
	ST24B ST24C	○	×	20μm	10μm	–	200	0.05μm	360mm/s	125ns	P13 - 16
							100	0.1μm	720mm/s		
							20	0.5μm	1200mm/s	250ns	
							10	1μm	1200mm/s		
	ST46-EZA	○	×	20μm	20μm	–	400	0.05μm	900mm/s	50ns	P17 - 20
							200	0.1μm	1800mm/s		
							40	0.5μm	2600mm/s		
							20	1μm	2600mm/s		
	ST422	○	×	40μm	40μm	–	200	0.2μm	1500mm/s	125ns	P21, 22
							80	0.5μm	3600mm/s		
							40	1μm	5000mm/s	250ns	
8							5μm	5000mm/s			
Assembly Type Linear Scales	AT103 AT113 AT112-F AT181	○	×	20μm	20μm	PSU-200	200	0.1μm	800mm/s	125ns	P23 - 26
							100	0.2μm	1600mm/s		
							80	0.25μm	2000mm/s*3		
							40	0.5μm			
							20	1μm			
							10	2μm			
							8	2.5μm			
							4	5μm			
	AT402E	○	△	20μm	20μm	–	–	–		2000mm/s	1Vp-p differential sine wave
	AT211	○	×	20μm	20μm	–	200	0.1μm	710mm/s	125ns	P31 - 36
							100	0.2μm	1400mm/s		
							40	0.5μm	2000mm/s	250ns	
							20	1μm			
							8	2.5μm		500ns	
							4	5μm		1000ns	
AT203	○	×	20μm	20μm	–	200	0.1μm	333mm/s	250ns	P37 - 40	
						40	0.5μm	1833mm/s			
						20	1μm	2000mm/s			
ABS AT500	–	○	20μm	20μm	–	4096	0.005μm	2500mm/s*4	–	P53 - 76	
ABS AT300	–	○	20μm	20μm	–	400	0.05μm	–	–	P77 - 80	
						400	0.05μm	2000mm/s	–		

*1 Maximum response speed of pulse output type uses the logical value (IC specification) with a margin of about 10%.

*2 For information on minimum edge interval, see "Explanation of Terms" on page 86.

The guaranteed value for minimum edge interval is +0%, -10%.

For some models, values other than shown above can also be selected.

*3 Maximum response speed is 2000mm/s for AT113 and 830mm/s (50m/min) for AT112, AT181, AT103-3250 and higher.

*4 Maximum response speed of H type with 0.005μm resolution is 1200mm/s.

Separate Type ST Series

Sinusoidal signal & Square-Wave Signal Output Scale Unit (High Accuracy Type)

ST36



Features

- High accuracy type, 0.5μm class (effective range up to 300mm)
- Has a thinner detector head (thickness 11.5mm).
- The maximum effective measurement length of 3000mm enables use on large machines.
- 4 different types available for each signal output specification.
- LED display function for indicating signal errors.

Specifications

Item	Code	ST36A	ST36B	ST36C	ST36D
Detection method		Reflective photoelectric linear encoder			
Main scale grating pitch		8μm			
Signal output pitch		4μm			
Output signal		2-phase sinusoidal signals	2-phase square wave signals (reset input type)	2-phase square wave signals 2-phase sinusoidal signals	1Vp-p differential sinusoidal signals
Effective range		10 - 3000mm			
Accuracy (20°C)		Effective range 10 to 300mm: ±0.5 μm Effective range 350 to 500mm: ±1.0 μm Effective range 600 to 1000mm: ±2.0 μm Effective range 1100 to 3000mm: ±2.0 μm/m			
Thermal expansion coefficient		(8±1) × 10 ⁻⁶ / °C			
Maximum response speed		1200mm/s (with sinusoidal signals output) (For 2-phase square wave signal types, see page 11)			
Scale reference point*		With scale reference point (50mm pitch, 10 to 80mm: Center point)			
Power supply		5VDC±5%			
Maximum current consumption		120mA	250mA		190mA
Operating temperature/humidity		0 to 40°C, 20 to 80% RH (no condensation)			
Storage temperature/humidity		-20 to 60°C, 20 to 80%RH (no condensation)			
Alarm indication		A scale alarm is indicated with an LED on the I/F box			

*Maximum speed for scale reference point detection is 20mm/s.

Parts

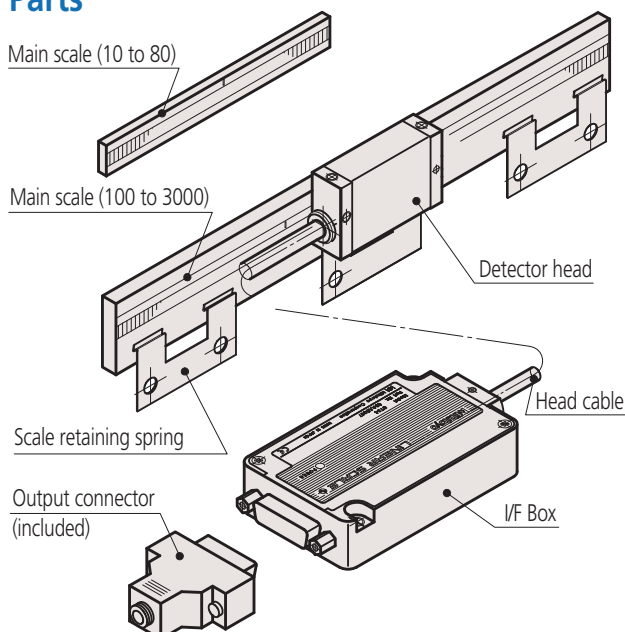

Alarm reset transmission/reception signal circuit (B Type)

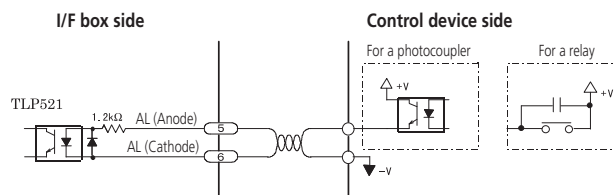

Reset input

Connect the alarm reset input circuit so that the current is 3 to 10mA. Also, the device has an internal resistor (1.2kΩ), so by applying 5 to 12V with a pulse width of at least 10ms across AL (anode)-AL (cathode), the alarm can be reset. When applying 12V or more, add an external resistance to limit the current to within the range stated above.

Output signal waveform

• 2-phase sinusoidal signals (Type A, C)

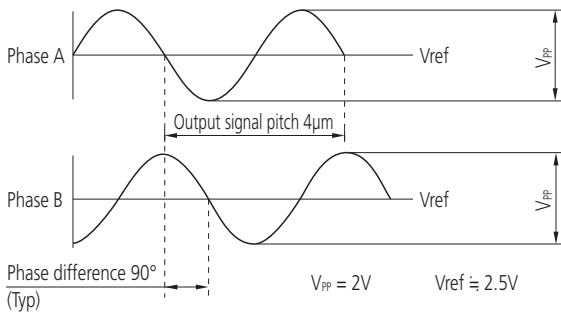

• Scale reference point

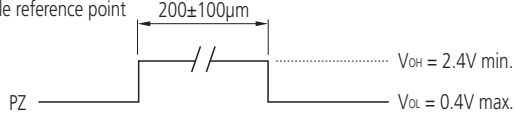

(Note) The phase difference between the PZ signal and the Phase A signal (and the Phase B signal) are not defined.

• 2-phase square wave signals (Type B, C)

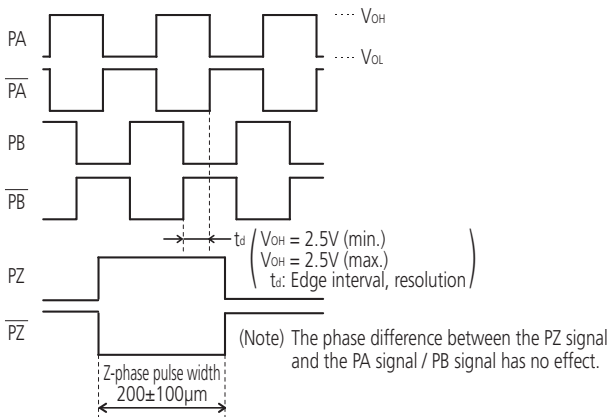

• 1Vp-p differential sinusoidal signals (Type D)

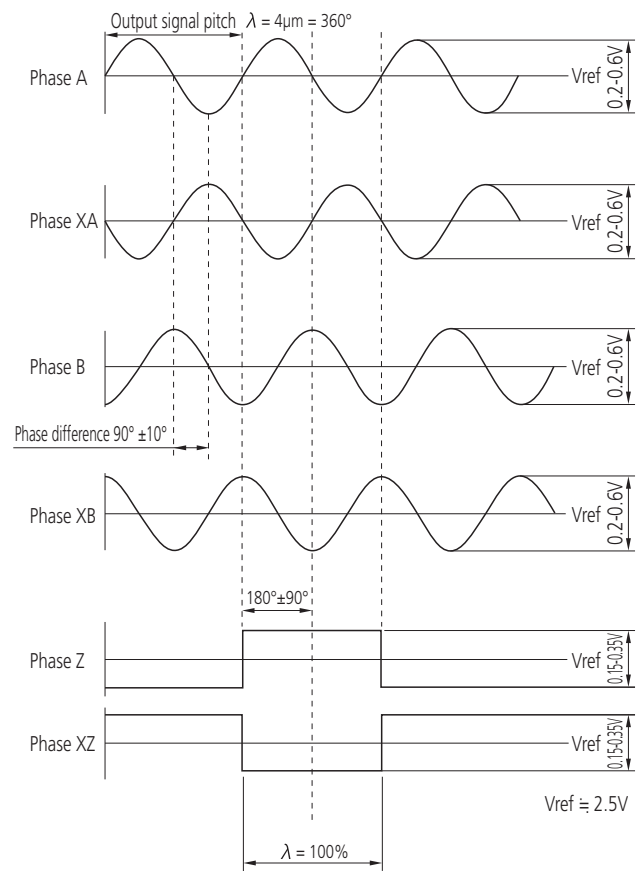

Output specification

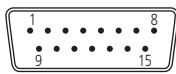

1. Output connector specification (Type A, B, C)

- Output connector (pin type): RDAD-15P-LNA(05) (Hirose Electric or equivalent)
- Applicable connector (standard accessory): D15-403N-110 (Technical Electron or equivalent)

2. Output connector specification (Type D)

- Output connector (pin type): RDAD-15P-LNA(05) inch screws (Hirose Electric or equivalent)
- Applicable connector (standard accessory): D15-403N-150 inch screws (Technical Electron or equivalent)

Pin No.	Type A Signal	Type B Signal	Type C Signal	Type D Signal
1	0V (GND)	0V (GND)	0V (GND)	Phase XA
2	0V (GND)	0V (GND)	0V (GND)	Phase XB
3	+5V	+5V	+5V	Phase Z
4	+5V	+5V	+5V	+5V (V_{DD})
5	Phase A	Reset input (anode)	Phase A	+5V (V_{DD})
6	Phase B	Reset input (cathode)	Phase B	N.C
7	Vref	Vref	Vref	N.C
8	PZ (scale reference point)	PZ (scale reference point)	PZ (scale reference point)	N.C
9	N.C	ALM (alarm, negative logic)	ALM (alarm, negative logic)	Phase A
10	Vref	PA	PA	Phase B
11	N.C	\overline{PA}	\overline{PA}	Phase XZ
12	N.C	PB	PB	0V (GND)
13	N.C	\overline{PB}	\overline{PB}	0V (GND)
14	N.C	PZ	PZ	N.C
15	F.G	F.G (= 0V)	F.G (= 0V)	0V (GND)

Specification Selection Method

- There is an extensive selection of specifications for ST36.
 - Choose the appropriate numbers and letters below according to specification required.
- If standard specifications (recommended items marked with ●/◎ symbols below) meet your requirements, please order using the code numbers shown on page 12.

How to read the code

ST36 - - - -

Signal output

Code	Output
A	Sinusoidal signal
B	Square wave signal + external reset input
C	Sinusoidal signal + Square wave signal
D	1Vp-p differential

Effective range

Code	Effective range (mm)	Code	Effective range (mm)
0010	10	0900	900
0025	25	1000	1000
0050	50	1100	1100
0075	75	1200	1200
0080	80	1300	1300
0100	100	1400	1400
0150	150	1500	1500
0200	200	1600	1600
0250	250	1700	1700
0300	300	1800	1800
0350	350	2000	2000
0400	400	2200	2200
0450	450	2400	2400
0500	500	2500	2500
0600	600	2600	2600
0700	700	2800	2800
0800	800	3000	3000

Note: For the standard specification, the indicated effective range depends on the product code.

Example of standard specification

Effective range 10mm: ST36 -0010

Effective range 250mm: ST36 -0250

Scale reference point

Code	Details
●A	50mm pitch (100 to 3000)
◎B	Center point (10 to 3000)
Z	Special position specification

Note: For reference positions in the effective range of 10 to 80mm, [B: Center point] is the standard specification.

Resolution / Minimum edge interval

Minimum edge interval / Resolution	125ns	250ns	500ns	1000ns
0.01μm	A: 70mm/s	B: 30mm/s	C: 15mm/s	D: 8mm/s
0.02μm	E: 150mm/s	F: 70mm/s	G: 30mm/s	H: 15mm/s
0.05μm	J: 360mm/s	K: 180mm/s	L: 90mm/s	M: 45mm/s
0.1 μm	N: 720mm/s	●P: 360mm/s	Q: 180mm/s	R: 90mm/s
—	◎Z: When [Signal output] is [A][D], maximum response speed at Sinusoidal signal -3 dB attenuation is 1.2m/s.			

Note: The minimum edge interval varies 0 to -10% based on the operating environmental conditions.

Special codes

Code	Details
●None	Standard selection specification
Z	Special specification

Note: If there are special details, please select Z.

Head cable length

Code	Length
●A	1m (High flex)
B	0.5m (High flex)
Z	Special length specification (max. 2.5m)

Note: If there are special details, please select Z.

Alarm output

Code	Details
●S	Alarm signal
H	High impedance
◎Z	When [Signal output] is [A] or [D]

Direction

Code	Details
●1	Normal: PA goes ahead
2	Reverse: PB goes ahead
◎Z	When [Signal output] is [A] or [D]

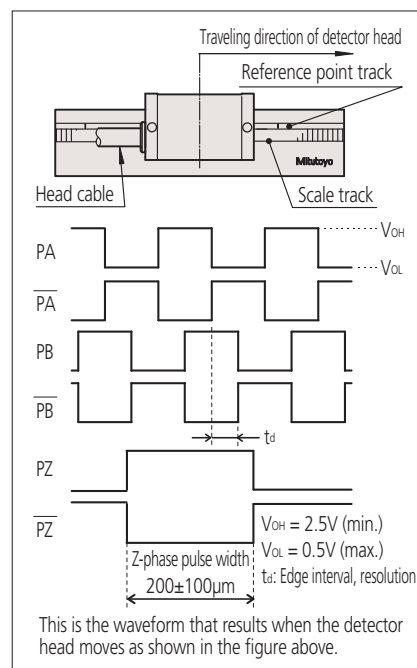

Mounting dimensions

• 10 to 80mm (Adhesive fixing type)

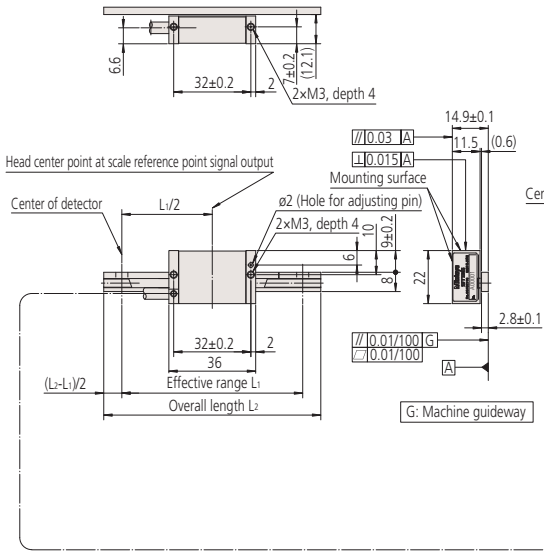

• 100 to 3000mm

Unit: mm

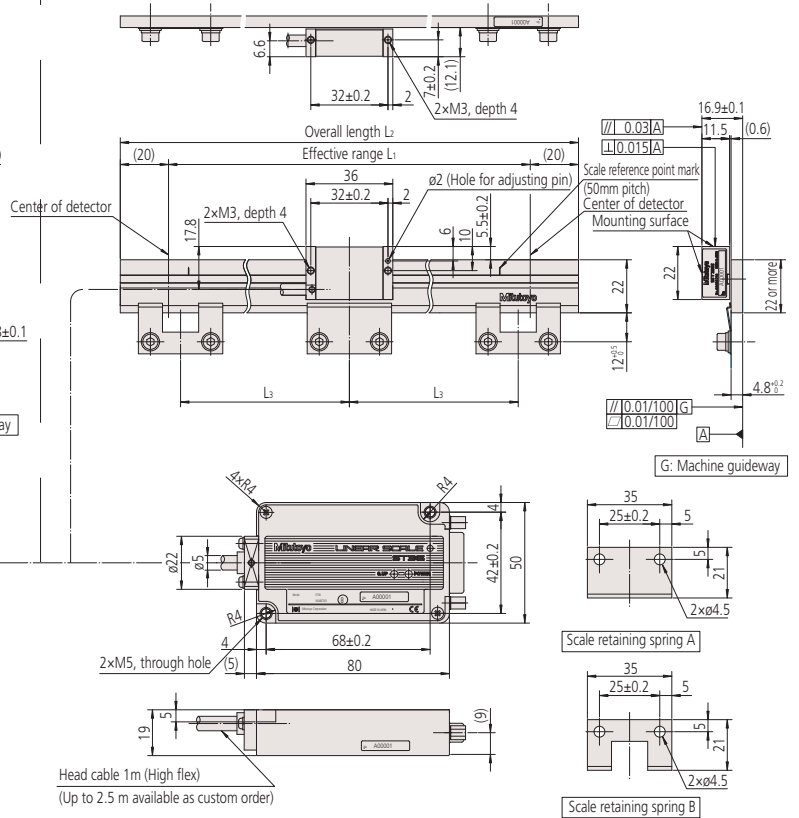

Dimensions of scale units

Order No.*	Code*	Effective range L ₁ (mm)	Overall length L ₂ (mm)	Scale fixing pitch L ₃ (mm)	Retaining spring A	Retaining spring B
579-501-0□	ST36◇-10	10	30	-	-	-
579-502-0□	ST36◇-25	25	45	-	-	-
579-503-0□	ST36◇-50	50	70	-	-	-
579-504-0□	ST36◇-75	75	90	-	-	-
579-505-0□	ST36◇-80	80	100	-	-	-
579-506-0□	ST36◇-100	100	140	50	1 pc.	2 pcs.
579-507-0□	ST36◇-150	150	190	75	1 pc.	2 pcs.
579-508-0□	ST36◇-200	200	240	100	1 pc.	2 pcs.
579-509-0□	ST36◇-250	250	290	60	1 pc.	4 pcs.
579-510-0□	ST36◇-300	300	340	75	1 pc.	4 pcs.
579-511-0□	ST36◇-350	350	390	85	1 pc.	4 pcs.
579-512-0□	ST36◇-400	400	440	100	1 pc.	4 pcs.
579-513-0□	ST36◇-450	450	490	75	1 pc.	6 pcs.
579-514-0□	ST36◇-500	500	540	80	1 pc.	6 pcs.
579-515-0□	ST36◇-600	600	640	100	1 pc.	6 pcs.
579-516-0□	ST36◇-700	700	740	85	1 pc.	8 pcs.
579-517-0□	ST36◇-800	800	840	100	1 pc.	8 pcs.

Order No.*	Code*	Effective range L ₁ (mm)	Overall length L ₂ (mm)	Scale fixing pitch L ₃ (mm)	Retaining spring A	Retaining spring B
579-518-0□	ST36◇-900	900	940	90	1 pc.	10 pcs.
579-519-0□	ST36◇-1000	1000	1040	100	1 pc.	10 pcs.
579-520-0□	ST36◇-1100	1100	1140	90	1 pc.	12 pcs.
579-521-0□	ST36◇-1200	1200	1240	100	1 pc.	12 pcs.
579-522-0□	ST36◇-1300	1300	1340	130	1 pc.	10 pcs.
579-523-0□	ST36◇-1400	1400	1440	100	1 pc.	14 pcs.
579-524-0□	ST36◇-1500	1500	1540	125	1 pc.	12 pcs.
579-525-0□	ST36◇-1600	1600	1640	100	1 pc.	16 pcs.
579-526-0□	ST36◇-1700	1700	1740	120	1 pc.	14 pcs.
579-527-0□	ST36◇-1800	1800	1840	100	1 pc.	18 pcs.
579-528-0□	ST36◇-2000	2000	2040	100	1 pc.	20 pcs.
579-529-0□	ST36◇-2200	2200	2240	100	1 pc.	22 pcs.
579-530-0□	ST36◇-2400	2400	2440	100	1 pc.	24 pcs.
579-531-0□	ST36◇-2500	2500	2540	95	1 pc.	26 pcs.
579-532-0□	ST36◇-2600	2600	2640	100	1 pc.	26 pcs.
579-533-0□	ST36◇-2800	2800	2840	100	1 pc.	28 pcs.
579-534-0□	ST36◇-3000	3000	3040	100	1 pc.	30 pcs.

* The above code numbers are for recommended items marked with ●/◎ symbols. If recommended specifications meet your requirements, use these code numbers to order.

* The □ and ◇ symbols in the tables above have the following meanings:
 ◇→A (2-phase sinusoidal signals) : □→1
 ◇→B (2-phase square wave signals + reset input) : □→2
 ◇→C (2-phase sinusoidal signals + 2-phase square wave signals) : □→3
 ◇→D (1Vp-p differential) : □→4

Separate Type ST Series

Sinusoidal signal & Square-Wave Signal Output Scale Unit (Standard Type)

ST24



Features

- Has a thinner detector head (thickness 11mm).
- The maximum effective measurement length of 3000mm enables use on large machines.
- 2 different types available for each signal output specification
- LED display function for indicating signal errors.

Specifications

Item	Code	ST24B	ST24C
Detection method		Reflective photoelectric linear encoder	
Main scale grating pitch		20μm	
Signal output pitch		10μm	
Output signal		2-phase square wave signals (reset input type)	2-phase square wave signals 2-phase sinusoidal signals
Effective range		10 to 3000mm	
Accuracy (20°C)		Effective range 10 to 300mm: ±1.0μm Effective range 350 to 500mm: ±2.0μm Effective range 600 to 1000mm: ±3.0μm Effective range 1100 to 3000mm: ±3.0 μm/m	
Thermal expansion coefficient		(8±1) x10 ⁻⁶ /°C	
Maximum response speed		1200mm/s (with sinusoidal signal output) (For 2-phase square wave signal types, see page 15)	
Scale reference point*		With scale reference point (50mm pitch, 10 to 80mm: Center point)	
Power supply		5VDC±5%	
Maximum current consumption		250mA	
Operating temperature/humidity		0 to 40°C, 20 to 80%RH (no condensation)	
Storage temperature/humidity		-20 to 60°C, 20 to 80%RH (no condensation)	
Alarm indication		LED illumination on the I/F box	

* Maximum speed for scale reference point detection is 20mm/s.

Component parts

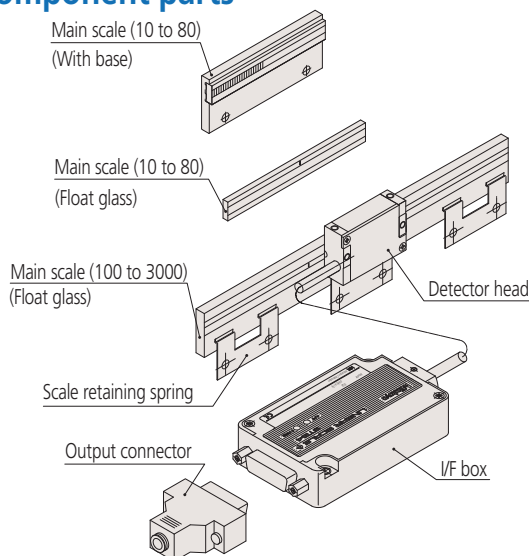

Alarm reset transmission/reception signal circuit (B Type)

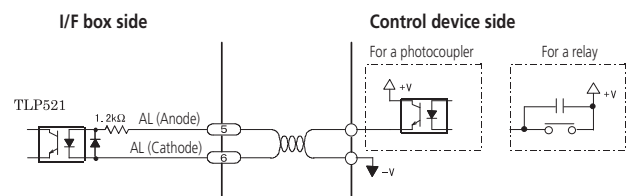

Reset input

Connect the alarm reset input circuit so that the current is 3 to 10mA. Also, the device has an internal resistor (1.2kΩ), so by applying 5 to 12V with a pulse width of at least 10ms across AL (anode)-AL (cathode), the alarm can be reset. When applying 12V or more, add an external resistance to limit the current to within the range stated above.

Output signal waveform

- 2-phase sinusoidal signals (Type C)

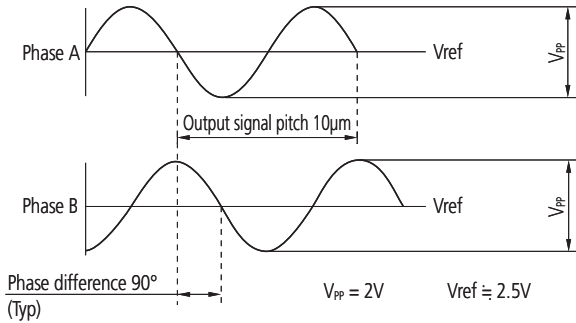

- Scale reference point

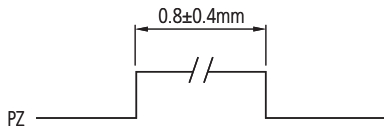

(Note) The phase difference between the PZ signal and the Phase A signal (and the Phase B signal) are not defined.

- 2-phase square wave signals (Type B, C)

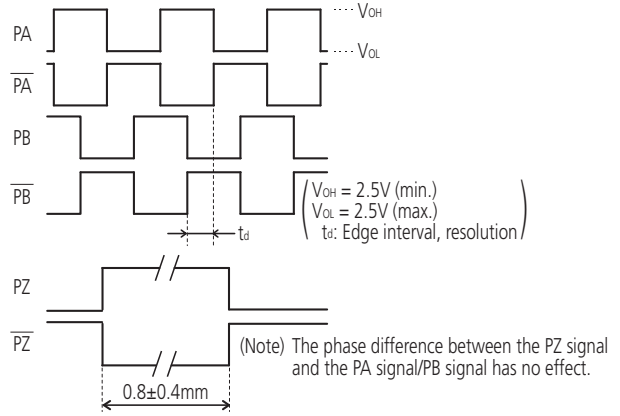

Output specification



Output connector specification

- Output connector (pin type): RDAD-15P-LNA(05) (Hirose Electric or equivalent)
- Suitable (standard accessory): D15-403N-110 (Technical Electron or equivalent)

Pin No.	Type B Signal	Type C Signal
1	0V (GND)	0V (GND)
2	0V (GND)	0V (GND)
3	+5V	+5V
4	+5V	+5V
5	Reset input (anode)	Phase A
6	Reset input (cathode)	Phase B
7	Vref	Vref
8	PZ	PZ
9	ALM (alarm, negative logic)	ALM (alarm, negative logic)
10	PA	PA
11	\overline{PA}	\overline{PA}
12	PB	PB
13	\overline{PB}	\overline{PB}
14	PZ	PZ
15	F.G	F.G

Specification Selection Method

- There is an extensive selection of specifications for the ST24.
 - Choose the appropriate numbers and letters below according to specification required.
- If standard specifications (recommended items marked with ●/◎ symbols below) meet your requirements, please use the code numbers shown on page 16 to order.

How to read the code

ST24 - - - -

Signal output

Code	Output
B	Square wave signal + external reset input
C	Sinusoidal signal + Square wave signal

Effective range

Code	Effective range (mm)	Code	Effective range (mm)
0010	10	0900	900
0025	25	1000	1000
0050	50	1100	1100
0075	75	1200	1200
0080	80	1300	1300
0100	100	1400	1400
0150	150	1500	1500
0200	200	1600	1600
0250	250	1700	1700
0300	300	1800	1800
0350	350	2000	2000
0400	400	2200	2200
0450	450	2400	2400
0500	500	2500	2500
0600	600	2600	2600
0700	700	2800	2800
0800	800	3000	3000

Note: For the standard specification, the indicated effective range depends on the product code.

Example of standard specification

Effective range 10mm: ST24□-0010

Effective range 250mm: ST24□-0250

Scale reference point

Code	Details
●A	50mm pitch (100 to 3000)
◎B	Center point (10 to 3000)
Z	Special position specification

Note: For reference positions in the effective range of 10 to 80mm, [B: Center point] is the standard specification.

Scale shape

Code	Detail - Cross-section (Effective range)
●A	Glass, separate: t4.8 x w22 (100 to 3000mm)
●B	Glass, separate: t2.8 x w8 (10 to 80mm)
C	With aluminum base: t5.1 x w23 (10 to 80mm)

Special codes

Code	Details
●None	Standard selection specification
Z	Special specification

Note: If there are special details, please select Z.

Head cable length

Code	Length
●A	1m
B	0.5m
Z	Special length specification (max. 2.5m)

Alarm output

Code	Details
●S	Alarm signal
H	High impedance

Direction

Code	Details
●1	Normal: PA goes ahead
2	Reverse: PB goes ahead

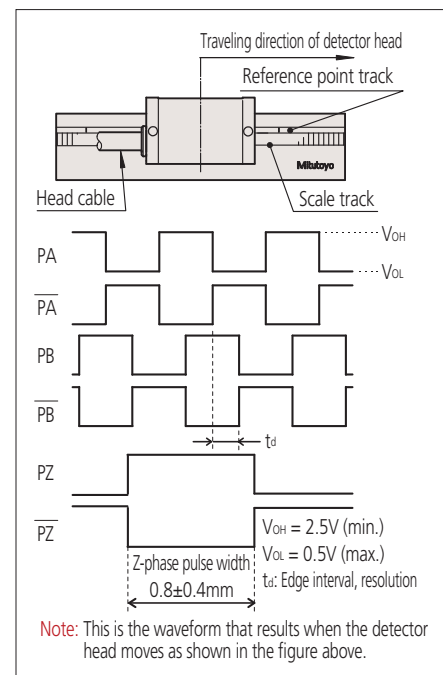

Resolution / Minimum edge interval

Resolution	Minimum edge interval			
	125ns	250ns	500ns	1000ns
0.05μm	A: 360mm/s	B: 180mm/s	C: 90mm/s	D: 45mm/s
0.1μm	E: 720mm/s	F: 360mm/s	G: 180mm/s	H: 90mm/s
0.5μm	J: 1200mm/s	K: 1200mm/s	L: 900mm/s	M: 450mm/s
1 μm	N: 1200mm/s	●P: 1200mm/s	Q: 1200mm/s	R: 900mm/s
—	◎Z: When [Signal output] is [A][D], maximum response speed at sine wave -3 dB attenuation is 1200mm/s.			

Note: The minimum edge interval varies 0 to -10% based on the operating environmental conditions.

Mounting dimensions

ST24 Specifications

ST24 Mounting dimensions

• 10 to 80mm (Adhesive fixing type) *

• 100 to 3000mm

Unit: mm

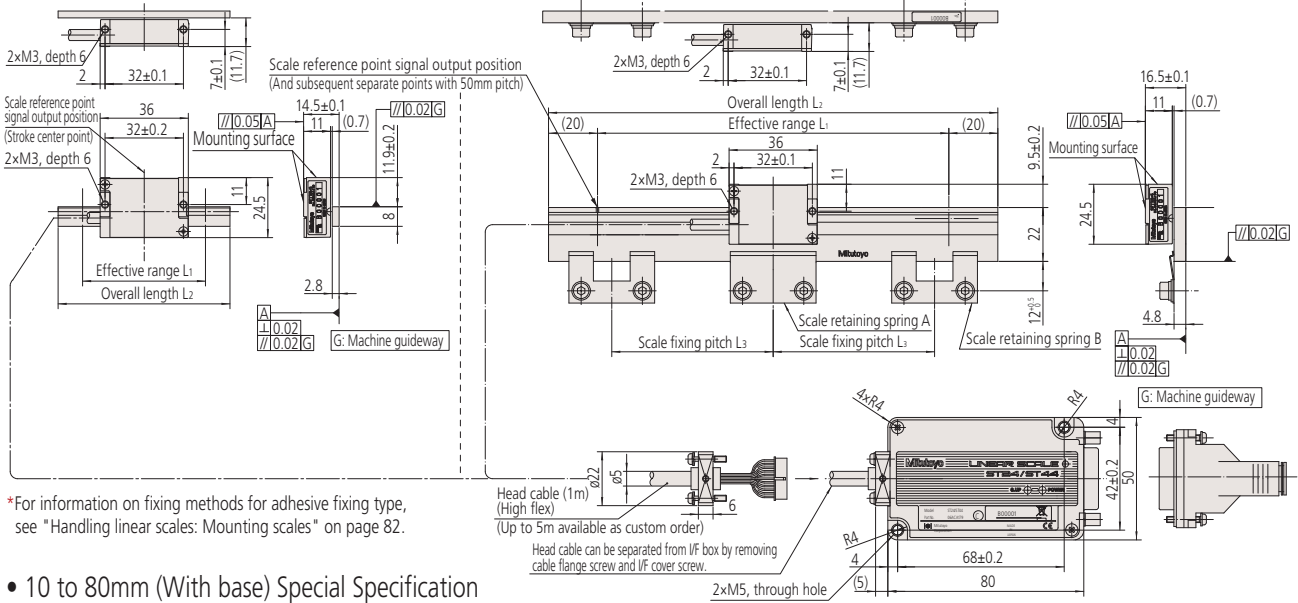

*For information on fixing methods for adhesive fixing type, see "Handling linear scales: Mounting scales" on page 82.

• 10 to 80mm (With base) Special Specification

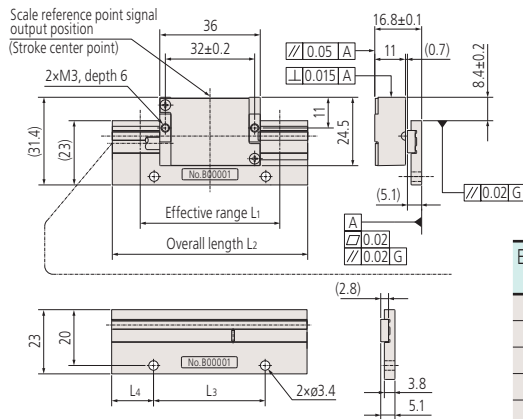

Effective range L ₁ (mm)	Overall length L ₂ (mm)	Scale fixing pitch	
		L ₃ (mm)	L ₄ (mm)
10	30	15	7.5
25	45	25	10
50	70	40	15
75	90	60	15
80	100	70	15

Dimensions of scale units

Order No. *	Code*	Effective range L ₁ (mm)	Overall length L ₂ (mm)	Scale fixing pitch L ₃ (mm)	Retaining spring A	Retaining spring B
579-551-0	ST24◇-10	10	30	-	-	-
579-552-0	ST24◇-25	25	45	-	-	-
579-553-0	ST24◇-50	50	70	-	-	-
579-554-0	ST24◇-75	75	90	-	-	-
579-555-0	ST24◇-80	80	100	-	-	-
579-556-0	ST24◇-100	100	140	50	1 pc.	2 pcs.
579-557-0	ST24◇-150	150	190	75	1 pc.	2 pcs.
579-558-0	ST24◇-200	200	240	100	1 pc.	2 pcs.
579-559-0	ST24◇-250	250	290	60	1 pc.	4 pcs.
579-560-0	ST24◇-300	300	340	75	1 pc.	4 pcs.
579-561-0	ST24◇-350	350	390	85	1 pc.	4 pcs.
579-562-0	ST24◇-400	400	440	100	1 pc.	4 pcs.
579-563-0	ST24◇-450	450	490	75	1 pc.	6 pcs.
579-564-0	ST24◇-500	500	540	80	1 pc.	6 pcs.
579-565-0	ST24◇-600	600	640	100	1 pc.	6 pcs.
579-566-0	ST24◇-700	700	740	85	1 pc.	8 pcs.
579-567-0	ST24◇-800	800	840	100	1 pc.	8 pcs.

*The □ and ◇ symbols in the tables above have the following meanings:
 ◇→B (2-phase square wave signals + external reset input) : □→2
 ◇→C (2-phase sinusoidal signals + 2-phase square wave signals) : □→3

Order No. *	Code*	Effective range L ₁ (mm)	Overall length L ₂ (mm)	Scale fixing pitch L ₃ (mm)	Retaining spring A	Retaining spring B
579-568-0	ST24◇-900	900	940	90	1 pc.	10 pcs.
579-569-0	ST24◇-1000	1000	1040	100	1 pc.	10 pcs.
579-570-0	ST24◇-1100	1100	1140	90	1 pc.	12 pcs.
579-571-0	ST24◇-1200	1200	1240	100	1 pc.	12 pcs.
579-572-0	ST24◇-1300	1300	1340	130	1 pc.	10 pcs.
579-573-0	ST24◇-1400	1400	1440	100	1 pc.	14 pcs.
579-574-0	ST24◇-1500	1500	1540	125	1 pc.	12 pcs.
579-575-0	ST24◇-1600	1600	1640	100	1 pc.	16 pcs.
579-576-0	ST24◇-1700	1700	1740	120	1 pc.	14 pcs.
579-577-0	ST24◇-1800	1800	1840	100	1 pc.	18 pcs.
579-578-0	ST24◇-2000	2000	2040	100	1 pc.	20 pcs.
579-579-0	ST24◇-2200	2200	2240	100	1 pc.	22 pcs.
579-580-0	ST24◇-2400	2400	2440	100	1 pc.	24 pcs.
579-581-0	ST24◇-2500	2500	2540	95	1 pc.	26 pcs.
579-582-0	ST24◇-2600	2600	2640	100	1 pc.	26 pcs.
579-583-0	ST24◇-2800	2800	2840	100	1 pc.	28 pcs.
579-584-0	ST24◇-3000	3000	3040	100	1 pc.	30 pcs.

Separate Type ST Series

Sinusoidal signal & Square-Wave Signal Output Scale Unit (Compact Type)

ST46-EZA

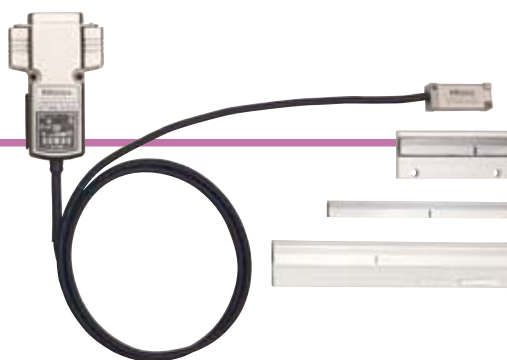

Features

- Ultra-compact, high-accuracy separate type linear scale great for applications where space is limited.
- Detector head mounting and signal adjustment possible without oscilloscope. Setup indicator for checking signal strength. Auto-tuning function activated by push switch.
- I/F circuit integrated in connector shell reduces volume to 60% compared to conventional interface.
- Self-diagnosis function with USB connectivity facilitates signal strength checking and parameter setup.
- Can be used for metal tape scale manufacture.

Specifications

Item	Code	ST46-EZA
Detection method		Reflective photoelectric linear encoder
Scale specifications		Grating pitch: 20 μ m, Material: glass
Main scale grating pitch		20 μ m
Output signal		Type B: 2-phase square wave signals, reference point pulse, external reset input Type C: 2-phase square wave signals, reference point pulse, 2-phase sinusoidal signals
Effective range		10 to 3000mm
Accuracy (20°C)		Effective range 10 to 300mm: $\pm 1\mu$ m Effective range 350 to 500mm: $\pm 2\mu$ m Effective range 600 to 1000mm: $\pm 3\mu$ m Effective range 1100 to 3000mm: $\pm 3\mu$ m/m
Thermal expansion coefficient		$(8\pm 1) \times 10^{-6}/^{\circ}\text{C}$
Scale reference point		With scale reference point (50mm pitch, 10 to 80mm: Center point)
Maximum response speed		2.6m/s (at sine wave amplitude -3dB)
Power supply voltage		5VDC $\pm 5\%$
Maximum current consumption		250mA
Operating temperature/humidity		0 to 40°C, 20 to 80%RH (no condensation)
Storage temperature/humidity		-20 to 60°C, 20 to 80%RH (no condensation)

Output specification

- Connector pin assignment (Type B)

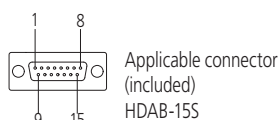

Pin No.	Signal	Pin No.	Signal
1, 2	0V (GND)	10	PA (main signal pulse_Normal phase)
3, 4	+5V (Vcc)	11	PA (main signal pulse_Reverse phase)
5	Reset input AL (anode)	12	PB (main signal pulse_Normal phase)
6	Reset input AL (cathode)	13	PB (main signal pulse_Reverse phase)
7	NC	14	PZ (reference point pulse_Reverse phase)
8	PZ (reference point pulse_Normal phase)	15	F. G
9	ALM (alarm)		

- Connector pin assignment (Type C)

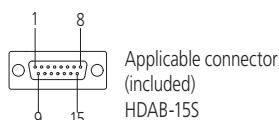

Pin No.	Signal	Pin No.	Signal
1, 2	0V (GND)	10	PA (main signal pulse_Normal phase)
3, 4	+5V (Vcc)	11	PA (main signal pulse_Reverse phase)
5	Phase A (sinusoidal signal)	12	PB (main signal pulse_Normal phase)
6	Phase B (sinusoidal signal)	13	PB (main signal pulse_Reverse phase)
7	Vref ($\approx V_{cc} / 2$)	14	PZ (reference point pulse_Reverse phase)
8	PZ (reference point pulse_Normal phase)	15	F. G
9	ALM (alarm)		

System Configuration

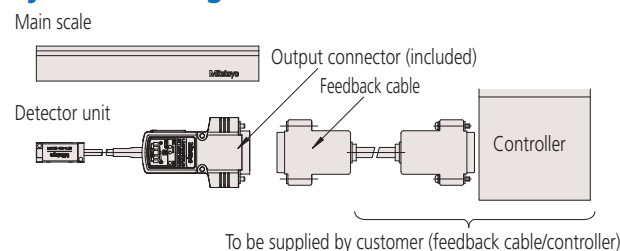

Output signal waveform and specification

- 2-phase square wave signals

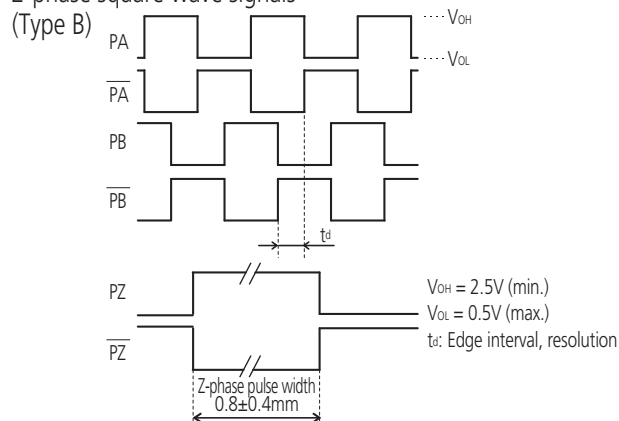

- 2-phase sinusoidal signals, 2-phase square wave signals

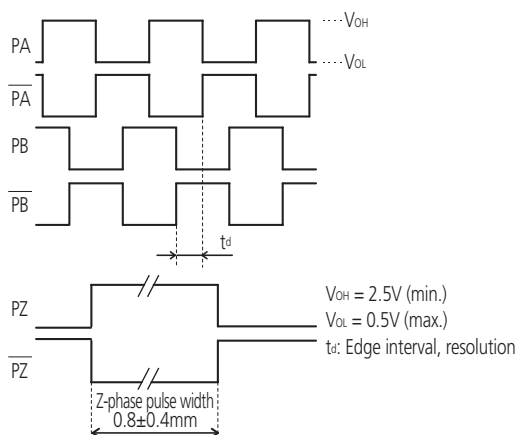
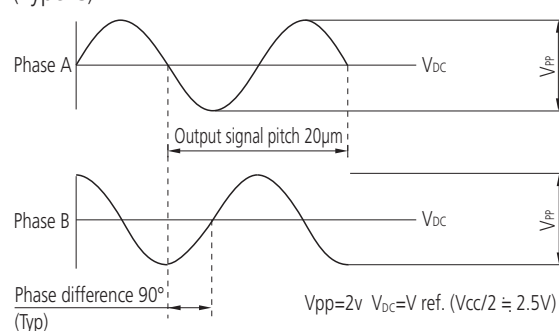

Specification Selection Method

- There is an extensive selection of specifications for the ST46-EZA.
- Choose the appropriate numbers and letters below according to specification required.
If standard specifications (recommended items marked with ● symbol below) meet your requirements, please order using the code numbers shown on pages 19 - 20.

How to read the code

ST46-EZA - -

Signal output

Code	Details
B	Square wave signal + external reset input
C	Sinusoidal signal + Square wave signal

Effective range

Code	Effective range (mm)	Code	Effective range (mm)	Code	Effective range (mm)
0010	10	0450	450	1600	1600
0025	25	0500	500	1700	1700
0050	50	0600	600	1800	1800
0075	75	0700	700	2000	2000
0080	80	0800	800	2200	2200
0100	100	0900	900	2400	2400
0150	150	1000	1000	2500	2500
0200	200	1100	1100	2600	2600
0250	250	1200	1200	2800	2800
0300	300	1300	1300	3000	3000
0350	350	1400	1400		
0400	400	1500	1500		

Note: For the standard specification, the indicated effective range depends on the product code.
Example of standard specification
Effective range 10mm: **ST46EZA** **0010**
Effective range 250mm: **ST46EZA** **0250**

Special codes

Code	Details
●None	Standard selection specification
Z	Special specification

Head cable length

Code	Length
●A	1m (standard)
B	0.5m
C	2m
Z	Special length specification (max. 2.5m)

Alarm output

Code	Details
●S	Alarm signal
H	High impedance

Direction

Code	Details
●1	Normal
2	Reverse

Reference point/ Scale shape

Code	Details (Effective range)	Details - Cross-section (Effective range)
●A	50mm pitch (100 to 3000mm)	Glass, separate: t4.8 x w22 (100 to 3000mm)
●B	Center point (10 to 80mm)	Glass, separate: t2.8 x w8 (10 to 80mm)
●C	Center point (10 to 80mm)	With aluminum base: t5.1 x w23 (10 to 80mm)
Z	Special position specification	Special shape

Resolution / Minimum edge interval

Code	Resolution	Minimum edge interval	Maximum response speed
A	0.05 μm	100 ns	450 mm/s
B		200 ns	225 mm/s
C		400 ns	112 mm/s
D		800 ns	56 mm/s
E	0.1 μm	100 ns	900 mm/s
●F		200 ns	450 mm/s
G		400 ns	225 mm/s
H	0.5 μm	800 ns	112 mm/s
J		100 ns	2600 mm/s
K		200 ns	2250 mm/s
L		400 ns	1125 mm/s
M	1 μm	800 ns	562 mm/s
N		100 ns	2600 mm/s
P		200 ns	2600 mm/s
Q	5 μm	400 ns	2250 mm/s
R		800 ns	1125 mm/s
S		100 ns	2600 mm/s
T		200 ns	2600 mm/s
U	5 μm	400 ns	2600 mm/s
V		800 ns	2600 mm/s

When the direction is normal, the sinusoidal signal, the 2-phase square wave output signal (Phase A, Phase B) and the reference point signal waveform are as shown below.

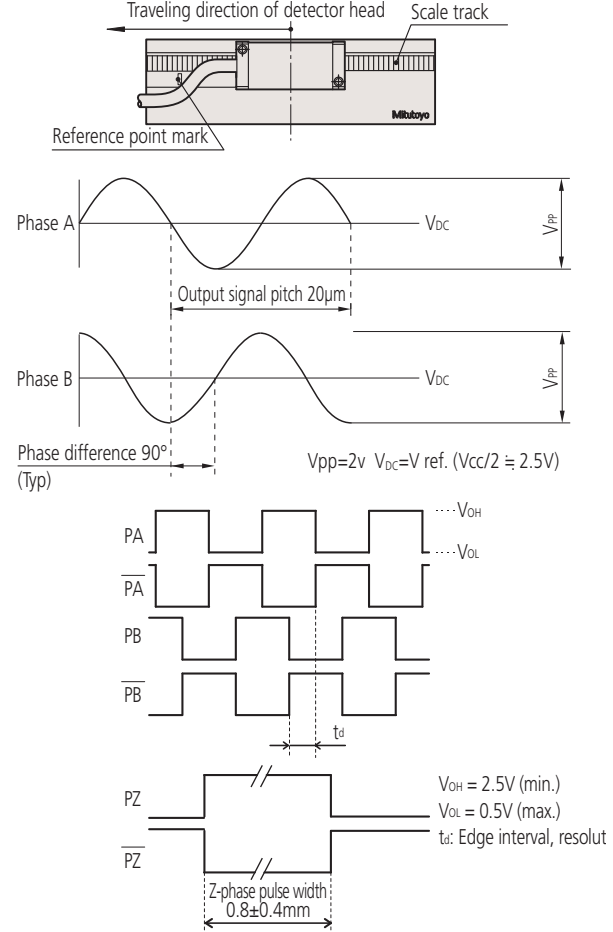

ST46-EZA Scale unit mounting dimensions

• Effective range 10 to 80mm (No aluminum base)

• Effective range 10 to 80mm (With aluminum base)

Unit: mm

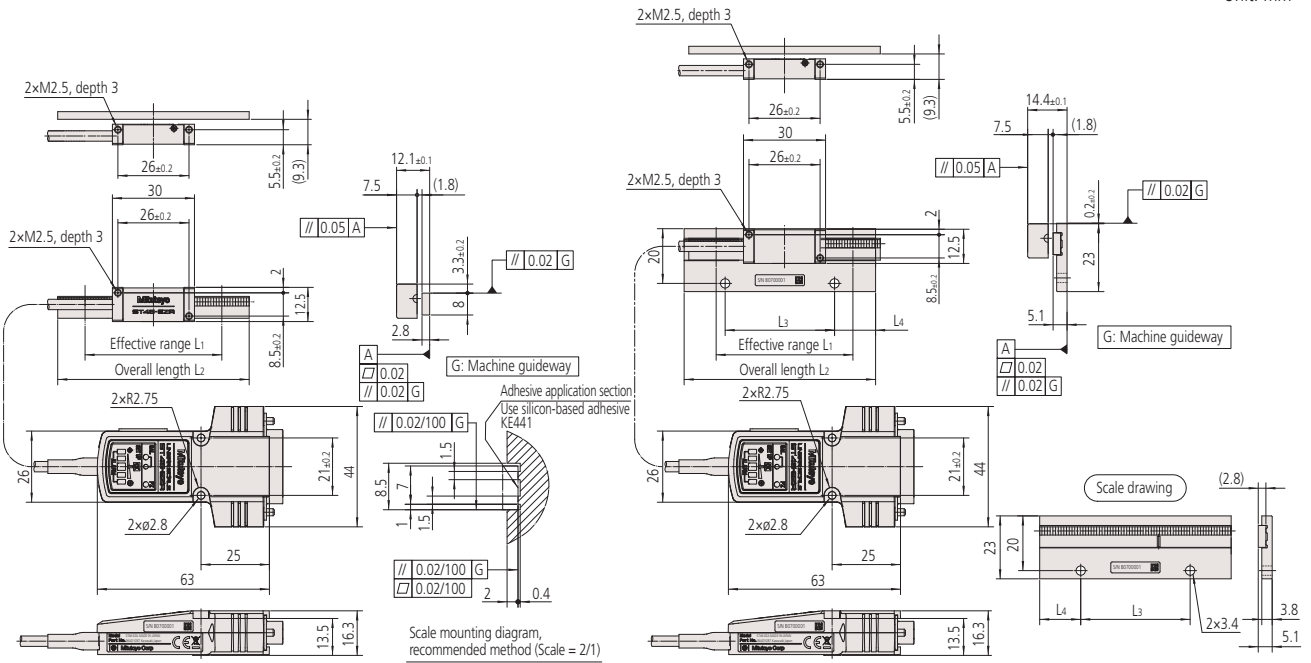

Separate Type ST Series
ST46-EZA

Dimensions of scale units

• 10 to 80mm (No aluminum base)

• 10 to 80 mm (With aluminum base)

Order No.	Code	Effective range L ₁ (mm)	Overall length L ₂ (mm)
579-665-12	ST46EZAB-10B	10	30
579-666-12	ST46EZAB-25B	25	45
579-667-12	ST46EZAB-50B	50	70
579-668-12	ST46EZAB-75B	75	90
579-669-12	ST46EZAB-80B	80	100
579-665-22	ST46EZAC-10B	10	30
579-666-22	ST46EZAC-25B	25	45
579-667-22	ST46EZAC-50B	50	70
579-668-22	ST46EZAC-75B	75	90
579-669-22	ST46EZAC-80B	80	100

Order No.	Code	Effective range L ₁ (mm)	Overall length L ₂ (mm)	L ₃ (mm)	L ₄ (mm)
579-665-13	ST46EZAB-10C	10	30	15	7.5
579-666-13	ST46EZAB-25C	25	45	25	10
579-667-13	ST46EZAB-50C	50	70	40	15
579-668-13	ST46EZAB-75C	75	90	60	15
579-669-13	ST46EZAB-80C	80	100	70	15
579-665-23	ST46EZAC-10C	10	30	15	7.5
579-666-23	ST46EZAC-25C	25	45	25	10
579-667-23	ST46EZAC-50C	50	70	40	15
579-668-23	ST46EZAC-75C	75	90	60	15
579-669-23	ST46EZAC-80C	80	100	70	15

• Effective range 100 to 3000mm

Unit: mm

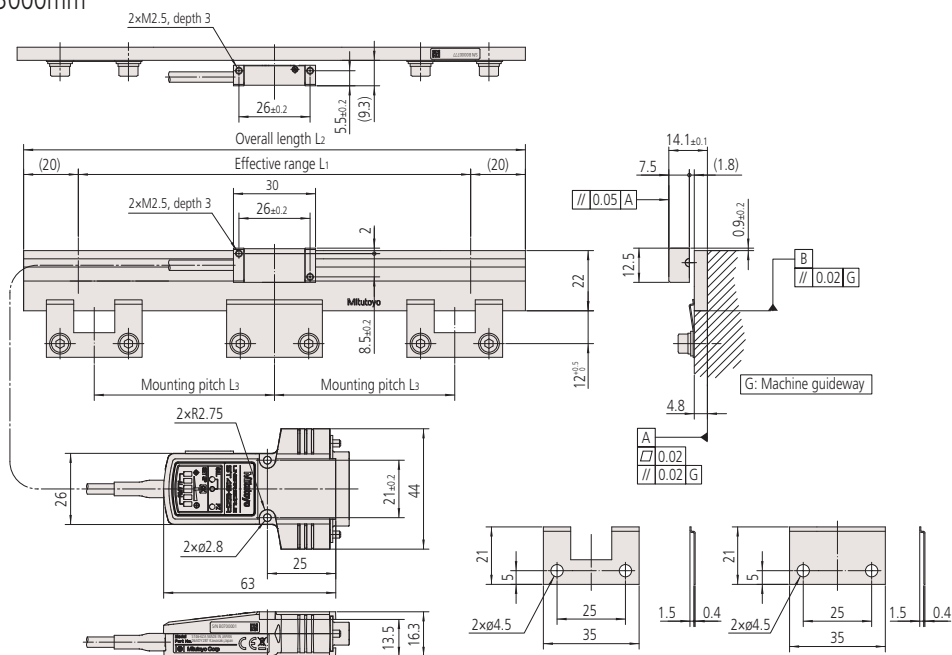

Dimensions of scale units

Order No.*	Code*	Effective range L ₁ (mm)	Overall length L ₂ (mm)	Scale fixing pitch L ₃ (mm)	Scale retaining spring A (pcs.)	Scale retaining spring B (pcs.)
579-670-□1	ST46EZA◇- 100A	100	140	50	1	2
579-671-□1	ST46EZA◇- 150A	150	190	75		2
579-672-□1	ST46EZA◇- 200A	200	240	100		2
579-673-□1	ST46EZA◇- 250A	250	290	60		4
579-674-□1	ST46EZA◇- 300A	300	340	75		4
579-675-□1	ST46EZA◇- 350A	350	390	85		4
579-676-□1	ST46EZA◇- 400A	400	440	100		4
579-677-□1	ST46EZA◇- 450A	450	490	75		6
579-678-□1	ST46EZA◇- 500A	500	540	80		6
579-679-□1	ST46EZA◇- 600A	600	640	100		6
579-680-□1	ST46EZA◇- 700A	700	740	85		8
579-681-□1	ST46EZA◇- 800A	800	840	100		8
579-682-□1	ST46EZA◇- 900A	900	940	90		10
579-683-□1	ST46EZA◇-1000A	1000	1040	100		10
579-684-□1	ST46EZA◇-1100A	1100	1140	90		12
579-685-□1	ST46EZA◇-1200A	1200	1240	100		12
579-686-□1	ST46EZA◇-1300A	1300	1340	130		10
579-687-□1	ST46EZA◇-1400A	1400	1440	100		14
579-688-□1	ST46EZA◇-1500A	1500	1540	125		12
579-689-□1	ST46EZA◇-1600A	1600	1640	100		16
579-690-□1	ST46EZA◇-1700A	1700	1740	120		14
579-691-□1	ST46EZA◇-1800A	1800	1840	100		18
579-692-□1	ST46EZA◇-2000A	2000	2040	100		20
579-693-□1	ST46EZA◇-2200A	2200	2240	100		22
579-694-□1	ST46EZA◇-2400A	2400	2440	100		24
579-695-□1	ST46EZA◇-2500A	2500	2540	95		26
579-696-□1	ST46EZA◇-2600A	2600	2640	100		26
579-697-□1	ST46EZA◇-2800A	2800	2840	100		28
579-698-□1	ST46EZA◇-3000A	3000	3040	100		30

* The above code numbers are for recommended items marked with ● symbol. If recommended specifications meet your requirements, please use these code numbers to order.
 ◇ → B (2-phase square wave signals + external reset input): □ → 1
 ◇ → C (2-phase square wave signals + 2-phase sinusoidal signals): □ → 2

- Application program (Option, Part No.06AEF800)

Adjustment SW / CAL display / Reference point display

NC side

SET UP OK

ALARM

Connector control unit has setup indicator

Signal strength checking and parameter setup can be performed on a PC (PC to be prepared by customer)

Separate Type ST Series

Sinusoidal signal & Square wave signal Output Scale Unit (Compact Type)

ST422

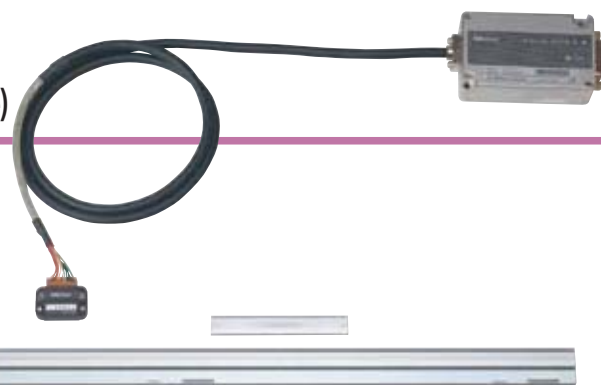

Features

- The maximum response speed is 5000mm/s.
(When resolution is 1μm and the minimum edge interval is 125ns)
- Compact detector unit control unit allow use in applications where space-saving design is important.
- The maximum effective measurement length of 3000mm enables use on large machines.
- LED display function for indicating signal errors.

Specifications

Item	Code	ST422
Detection method		Reflective photoelectric linear encoder
Main scale grating pitch		40μm
Signal output pitch		40μm
Output signal		Two 90° phase-shifted sinusoidal signals and two 90° phase-shifted square wave signals, scale reference point signal, alarm signal
Effective range		10 to 3000mm
Accuracy (20°C)		Effective range 10 to 300mm: ±1.0μm Effective range 350 to 500mm: ±2.0μm Effective range 600 to 1000mm: ±3.0μm Effective range 1100 to 3000mm: ±3.0μm/m
Thermal expansion coefficient		(8±1) × 10 ⁻⁶ / °C
Maximum response speed		5000mm/s (depending on setting)
Scale reference point		With scale reference point (50mm pitch, 10 to 75mm: Center point)
Power supply		5VDC±5%
Maximum current consumption		200mA (Max)
Operating temperature/humidity		0 to 40°C, 20 to 80%RH (no condensation)
Storage temperature/humidity		-20 to 60°C, 20 to 80%RH (no condensation)
Alarm indication		LED illumination on the I/F box
Head cable length		1m*

* For high flex type head cable, please contact us.

I/F box output connector pin assignment

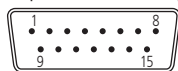

Output connector (pin type): RDAD-15P-LNA(05) (Hirose Electric or equivalent)
Suitable plug (standard accessory): D15-403N-110 (Technical Electron or equivalent)

Pin No.	Signal
1	0V (GND)
2	0V (GND)
3	+5V (Vcc)
4	+5V (Vcc)
5	Phase A (Sinusoidal signal)
6	Phase B (Sinusoidal signal)
7	Vref
8	PZ (scale reference point)
9	ALM (alarm, negative logic)
10	PA
11	PA
12	PB
13	PB
14	PZ
15	F. G

Output signal waveform

• 2-phase sinusoidal signals

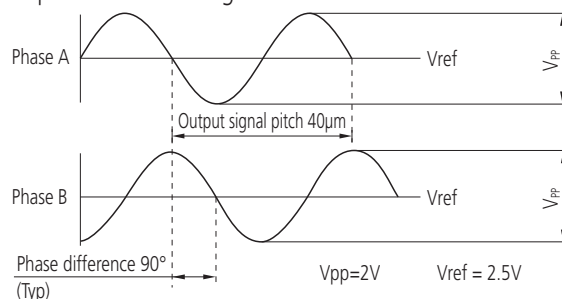

• Scale reference point

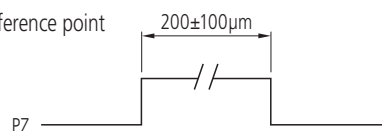

(Note) The phase difference between the PZ signal and the Phase A signal (and the Phase B signal) are not defined.

• 2-phase square wave signals

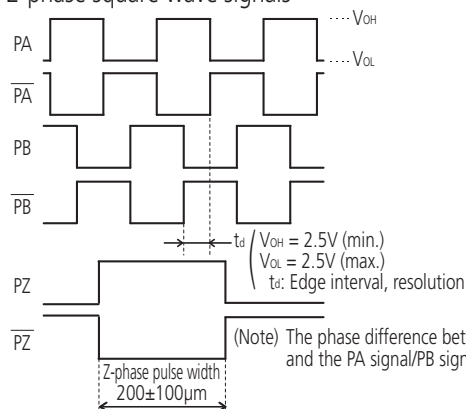

Maximum response speed

Maximum response speed depends on setting, as shown below.

Resolution (number of divisions)	Setting		Maximum response speed (mm/s) (Scale pitch: 40μm)
	Minimum edge interval [+0, -10%]		
5μm (8)	125ns		5000
	250ns		5000
	500ns		3600
	1000ns		1800
1μm (40)	125ns		5000
	250ns		3600
	500ns		1800
	1000ns		900
0.5μm (80)	125ns		3600
	250ns		1800
	500ns		900
	1000ns		450
0.2μm (200)	125ns		1500
	250ns		700
	500ns		300
	1000ns		150

Note: The minimum edge interval varies 0 to -10% based on the operating environmental conditions.

ST422 Scale unit mounting dimensions

• ST422-10 to 350 (Adhesive fixing type) *3

• ST422-400 to 3000

Unit: mm

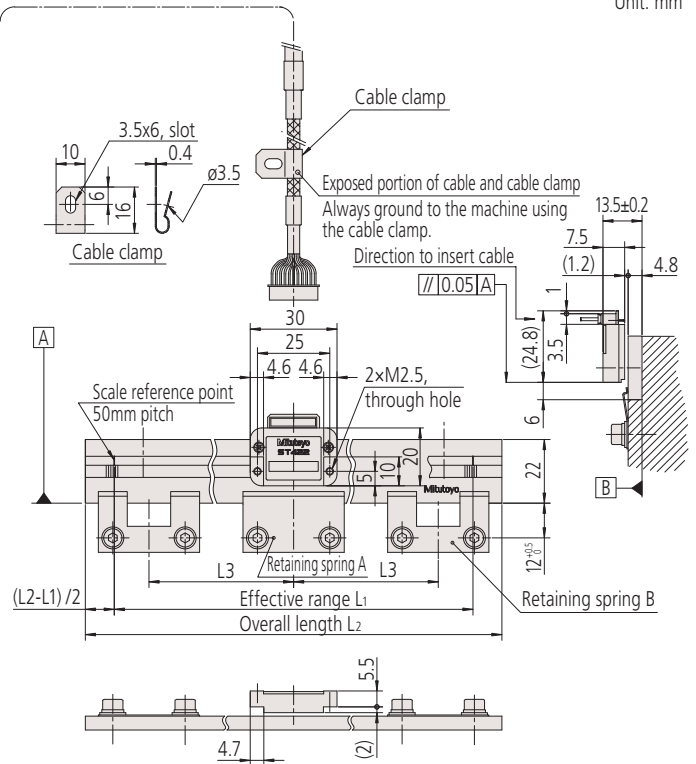
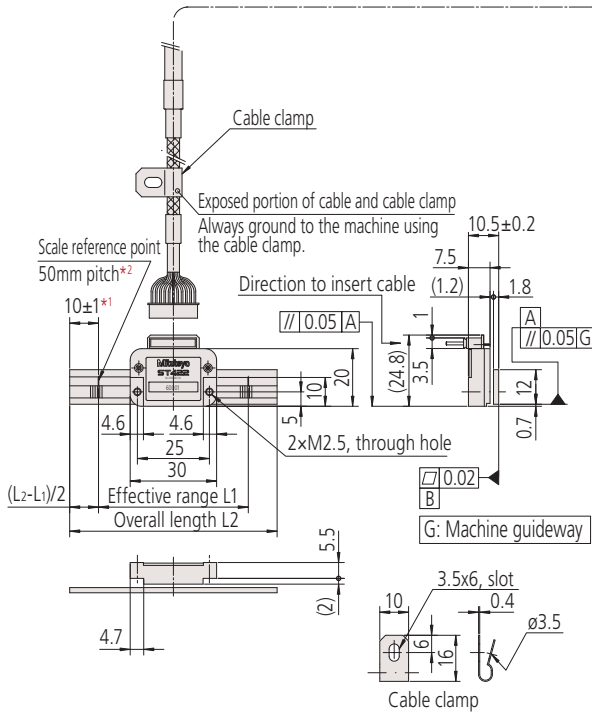

- *1 When stroke is 100mm or longer
- *2 One center point when stroke is 10 to 75mm
- *3 For information on fixing methods for adhesive fixing type, see "Handling linear scales Mounting scales" on page 82

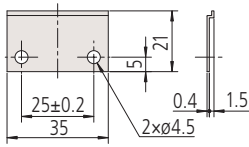

Retaining spring A

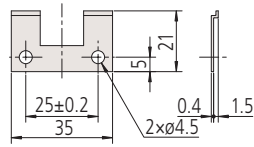

Retaining spring B

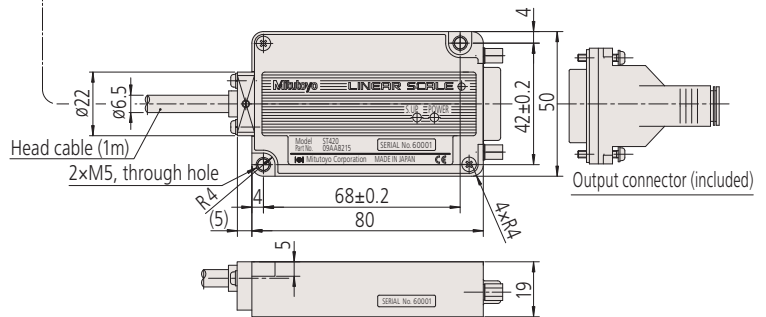

Dimensions of scale units

Order No.	Code	Effective range L ₁ (mm)	Overall length L ₂ (mm)	Scale fixing pitch L ₃ (mm)	Retaining spring A	Retaining spring B
579-631	ST422-10	10	30	—	—	—
579-632	ST422-25	25	45	—	—	—
579-633	ST422-50	50	70	—	—	—
579-634	ST422-75	75	95	—	—	—
579-635	ST422-100	100	120	—	—	—
579-636	ST422-150	150	170	—	—	—
579-637	ST422-200	200	220	—	—	—
579-638	ST422-250	250	270	—	—	—
579-639	ST422-300	300	320	—	—	—
579-640	ST422-350	350	370	—	—	—
579-641	ST422-400	400	440	100	1 pc.	4 pcs.
579-642	ST422-450	450	490	75	1 pc.	6 pcs.
579-643	ST422-500	500	540	80	1 pc.	6 pcs.
579-644	ST422-600	600	640	100	1 pc.	6 pcs.
579-645	ST422-700	700	740	85	1 pc.	8 pcs.
579-646	ST422-800	800	840	100	1 pc.	8 pcs.
579-647	ST422-900	900	940	90	1 pc.	10 pcs.

Order No.	Code	Effective range L ₁ (mm)	Overall length L ₂ (mm)	Scale fixing pitch L ₃ (mm)	Retaining spring A	Retaining spring B
579-648	ST422-1000	1000	1040	100	1 pc.	10 pcs.
579-649	ST422-1100	1100	1140	90	1 pc.	12 pcs.
579-650	ST422-1200	1200	1240	100	1 pc.	12 pcs.
579-651	ST422-1300	1300	1340	130	1 pc.	10 pcs.
579-652	ST422-1400	1400	1440	100	1 pc.	14 pcs.
579-653	ST422-1500	1500	1540	125	1 pc.	12 pcs.
579-654	ST422-1600	1600	1640	100	1 pc.	16 pcs.
579-655	ST422-1700	1700	1740	120	1 pc.	14 pcs.
579-656	ST422-1800	1800	1840	100	1 pc.	18 pcs.
579-657	ST422-2000	2000	2040	100	1 pc.	20 pcs.
579-658	ST422-2200	2200	2240	100	1 pc.	22 pcs.
579-659	ST422-2400	2400	2440	100	1 pc.	24 pcs.
579-660	ST422-2500	2500	2540	95	1 pc.	26 pcs.
579-661	ST422-2600	2600	2640	100	1 pc.	26 pcs.
579-662	ST422-2800	2800	2840	100	1 pc.	28 pcs.
579-663	ST422-3000	3000	3040	100	1 pc.	30 pcs.

- Dimensions L4, L5, and L6 indicate the recommended mounting positions for the middle supports included with scale units with an effective range of 1000mm and more. (The position of the middle support is adjustable in the measuring length direction.)

Effective range (mm)	Middle support
1000 - 1500	(1 place)
1600 - 2200	BC (2 places)
2400 - 3000	ABC (3 places)

Dimensions of scale units

AT103		Effective range L ₀ (mm)	Maximum travel length L ₁ (mm)	Mounting hole pitch L ₂ (mm)	Overall length L ₃ (mm)	Middle support L ₄ (mm)	Middle support L ₅ (mm)	Middle support L ₆ (mm)	Signal cable length (m)
Order No.	Code								
539-111-30	AT103- 100	100	120	248	268				3
539-112-30	AT103- 150	150	170	298	318				
539-113-30	AT103- 200	200	220	348	368				
539-114-30	AT103- 250	250	270	398	418				
539-115-30	AT103- 300	300	330	458	478				
539-116-30	AT103- 350	350	380	508	528				
539-117-30	AT103- 400	400	430	558	578				
539-118-30	AT103- 450	450	480	608	628				
539-119-30	AT103- 500	500	540	668	688				
539-121-30	AT103- 600	600	650	778	798				
539-123-30	AT103- 700	700	760	888	908				
539-124-30	AT103- 750	750	810	938	958				
539-125-30	AT103- 800	800	860	988	1008				
539-126-30	AT103- 900	900	960	1088	1108				
539-127-30	AT103-1000	1000	1060	1188	1208	594			
539-128-30	AT103-1100	1100	1160	1288	1308	644			
539-129-30	AT103-1200	1200	1260	1388	1408	694			
539-130-30	AT103-1300	1300	1360	1488	1508	744			
539-131-30	AT103-1400	1400	1460	1488	1608	794			
539-132-30	AT103-1500	1500	1560	1688	1708	844			
539-133-30	AT103-1600	1600	1690	1818	1838		610		
539-134-30	AT103-1700	1700	1790	1918	1938		650		
539-135-30	AT103-1800	1800	1890	2018	2038		670		
539-136-30	AT103-2000	2000	2100	2228	2248		740		
539-137-30	AT103-2200	2200	2300	2428	2448		800		
539-138-30	AT103-2400	2400	2500	2628	2648	1314	1300	650	
539-139-30	AT103-2500	2500	2600	2728	2748	1364	1340	670	
539-140-30	AT103-2600	2600	2700	2828	2848	1414	1400	700	
539-141-30	AT103-2800	2800	2900	3028	3048	1514	1500	750	
539-142-30	AT103-3000	3000	3100	3228	3248	1614	1600	800	

Note 1: For effective ranges of 100 to 2000mm, we also have the high-accuracy AT103F JIS Class 0 (3+3L₀/1000) μm models available.

Note 2: The ultra-high-accuracy AT103S (2+2L₀/1000) μm models for effective ranges of 100 to 500mm may be custom-ordered on request.

Note 3: The accuracy does not include quantizing error; L₀ is the effective range (mm).

Mounting dimensions (Effective range: 3250 to 6000mm)

AT103 (Standard type)

Unit: mm

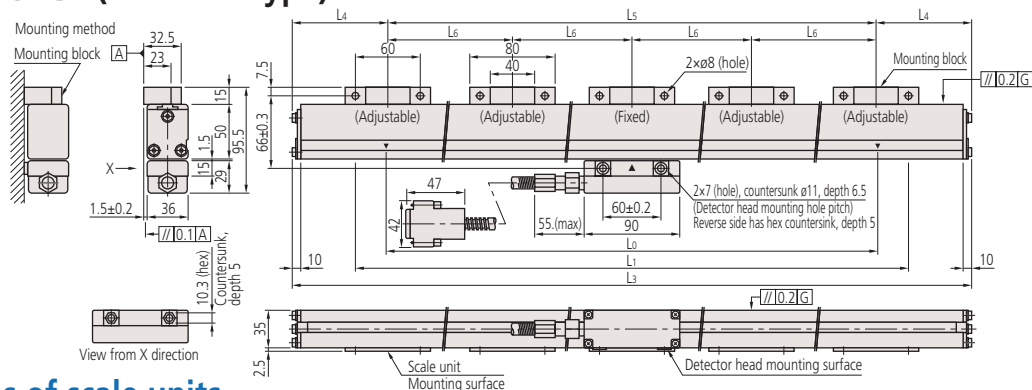

Dimensions of scale units

Order No.	Code	Effective range L ₀ (mm)	Maximum travel length L ₁ (mm)	Overall length L ₃ (mm)	Mounting block L ₄ (mm)	Mounting block L ₅ (mm)	Mounting block L ₆ (mm)	Signal cable length (m)
539-143-30	AT103-3250	3250	3350	3470	135	3200	800	10
539-144-30	AT103-3500	3500	3600	3720	160	3400	850	
539-145-30	AT103-3750	3750	3850	3970	125	3720	930	
539-146-30	AT103-4000	4000	4100	4220	110	4000	1000	
539-147-30	AT103-4250	4250	4350	4470	135	4200	1050	
539-148-30	AT103-4500	4500	4600	4720	160	4400	1100	
539-149-30	AT103-4750	4750	4850	4970	85	4800	800	
539-150-30	AT103-5000	5000	5100	5220	120	4980	830	15
539-151-30	AT103-5250	5250	5350	5470	125	5220	870	
539-152-30	AT103-5500	5500	5600	5720	130	5460	910	
539-153-30	AT103-5750	5750	5850	5970	135	5700	950	
539-154-30	AT103-6000	6000	6100	6220	110	6000	1000	

Note: Accuracy is (5+8L₀/1000) μm.

Dimensions of scale units

AT181		Effective range L ₀ (mm)	Maximum travel length L ₁ (mm)	Mounting hole pitch L ₂ (mm)	Unit (frame) length L ₃ (mm)	Signal cable length (m)
Order No.	Code					
539-301	AT181-100	100	130	255	270	3
539-302	AT181-150	150	180	305	320	
539-303	AT181-200	200	230	355	370	
539-304	AT181-250	250	280	405	420	
539-305	AT181-300	300	330	455	470	
539-306	AT181-350	350	380	505	520	
539-307	AT181-400	400	430	555	570	
539-308	AT181-450	450	480	605	620	
539-309	AT181-500	500	530	655	670	
539-310	AT181-550	550	580	705	720	
539-311	AT181-600	600	630	755	770	

Note 1: We have no high-accuracy AT181F JIS Class 0 ($3+3L_0/1000$) μm models.

Note 2: The accuracy does not include quantizing error; L₀ is the effective range (mm).

Mounting dimensions (Effective range: 50 to 1020mm)

AT112-F (Super slim spar type)

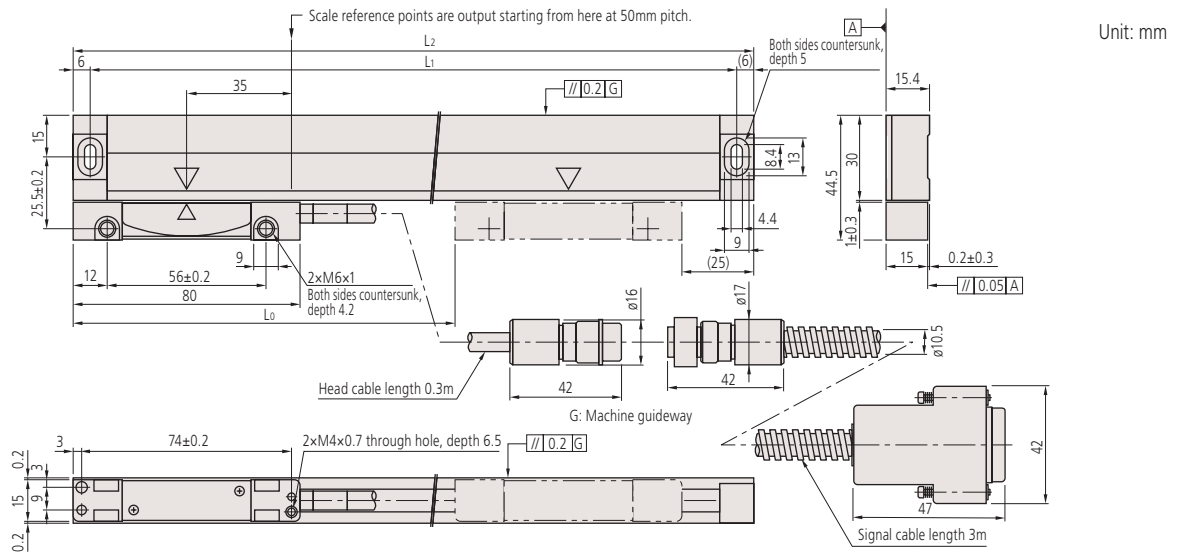

Dimensions of scale units

AT112		Effective range L ₀ (mm)	Mounting hole pitch L ₁ (mm)	Overall length L ₂ (mm)	Signal cable length (m)
Order No.	Code				
539-251-10	AT112- 50F	50	143	155	3
539-252-10	AT112- 70F	70	163	175	
539-253-10	AT112- 120F	120	213	225	
539-254-10	AT112- 170F	170	263	275	
539-255-10	AT112- 220F	220	313	325	
539-256-10	AT112- 270F	270	363	375	
539-257-10	AT112- 320F	320	413	425	
539-258-10	AT112- 370F	370	463	475	
539-259-10	AT112- 420F	420	513	525	
539-260-10	AT112- 470F	470	563	575	
539-261-10	AT112- 520F	520	613	625	
539-262-10	AT112- 570F	570	663	675	
539-263-10	AT112- 620F	620	713	725	
539-264-10	AT112- 670F	670	763	775	
539-265-10	AT112- 720F	720	813	825	
539-266-10	AT112- 770F	770	863	875	
539-267-10	AT112- 820F	820	913	925	
539-268-10	AT112- 920F	920	1013	1025	
539-269-10	AT112-1020F	1020	1113	1125	

Note 1: The ultra-high-accuracy AT112S ($2+2L_0/1000$) μm models for effective ranges of 50 to 320mm may be custom-ordered on request.

Note 2: The accuracy does not include quantizing error; L₀ is the effective range (mm).

Note 3: For AT112-50F and 70F only, there is one scale reference point at the midpoint.

Assembly Type AT Series

1Vpp Differential Signal Output Type Scale Unit

AT402E



Features

- Ideal for machine tools for heavy cutting as well as linear motors.
- Has multi-point elastic fixing for excellent vibration resistance (200m/s^2), shock resistance (400m/s^2), and temperature characteristics.
- The adoption of the Absolute Interval Code has enabled a simplified, low-cost ABS system.

Specifications

Item	Code	AT402E-A Type	AT402E-B Type	AT402E-C Type
Cable configuration		3m single wire	3m European CNC manufacturers' specification	3m FANUC LTD. specification
Detection method		Photoelectric linear encoder		
Base position of elongation due to temperature changes		Midpoint of the screws used for rigid fixing near the midpoint of the effective range.		
Effective range		140 to 3040mm		
Output signal		Signal: 1Vpp differential Sinusoidal signal, differential reference point pulse: Absolute Interval Code compatible		
Signal output pitch		20 μm		
Maximum response speed		120m/min (with Sinusoidal signal amplitude of -3db)		
Accuracy (20°C)		Effective range 140 to 540mm : $\pm 2\mu\text{m}$ Effective range 640 to 940mm : $\pm 3\mu\text{m}$ Effective range 1040 to 3040mm : $\pm 3\mu\text{m/m}$		
Thermal expansion coefficient		$(8\pm 1)\times 10^{-6}/^\circ\text{C}$		
Operating temperature/humidity		0 to 45°C 20 to 80% RH (no condensation)		
Storage temperature/humidity		-20 to 70°C 20 to 80% RH (no condensation)		
Vibration resistance		200 m/s^2 (55 to 2000Hz)		
Shock resistance		400 m/s^2 (half-sine 11ms)		
Power supply voltage		5VDC $\pm 5\%$		
Maximum current consumption		120mA		
Maximum sliding force		4N		
Protection rating		Equivalent to IP53		
Air supply hole		With air supply hole (end of scale frame/detector head)		

Note 1: For details regarding the applicable system, please consult with the individual manufacturer.

Cable configuration

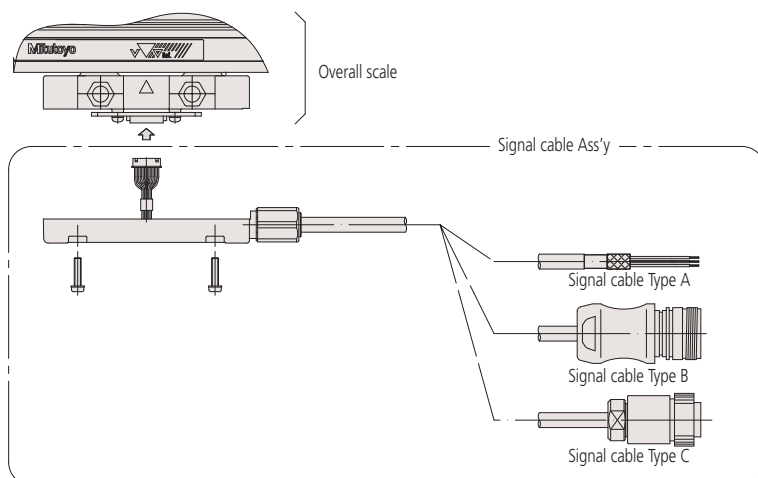

Pin assignment

(1) Signal cable A (single wire specification)

Wire color	Signal	Wire color	Signal
White	+5V	Yellow	Phase XB
Black	GND	Green	Phase Z
Brown	Phase A	Blue	Phase XZ
Red	Phase XA	Shield	FG
Orange	Phase B		

Note 1: Ground the shield to the earth bar

(2) Signal cable B (European CNC manufacturer's specification)

12-pin Type Connector without locking ring

Pin	Signal	Pin	Signal
2,12	+5V	1	Phase XB
10,11	GND	3	Phase Z
5	Phase A	4	Phase XZ
6	Phase XA	Shell	FG
8	Phase B	7,9	Not used

(3) Signal cable C (FANUC LTD. specification)

12-pin Type Connector

Pin	Signal	Pin	Signal
1,2	+5V	8	Phase XB
3,4	GND	9	Phase Z
5	Phase A	10	Phase XZ
6	Phase XA	11, shell	FG
7	Phase B	12	Not used

Note 1: Connector used: RM15WTP-12P

Note 2: Applicable connector: RM15WTR-12S
(Hirose Electric or equivalent product)

Output signal waveform

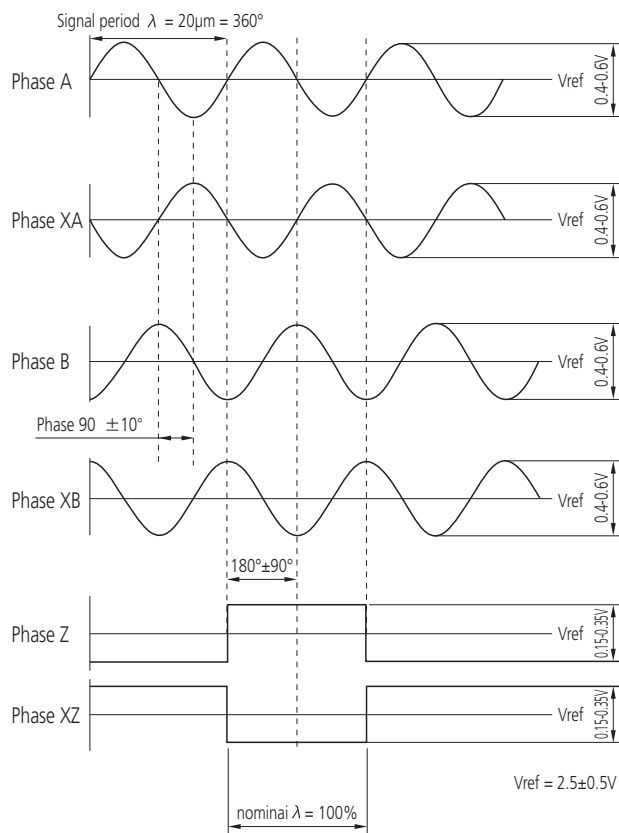

Absolute Interval Code

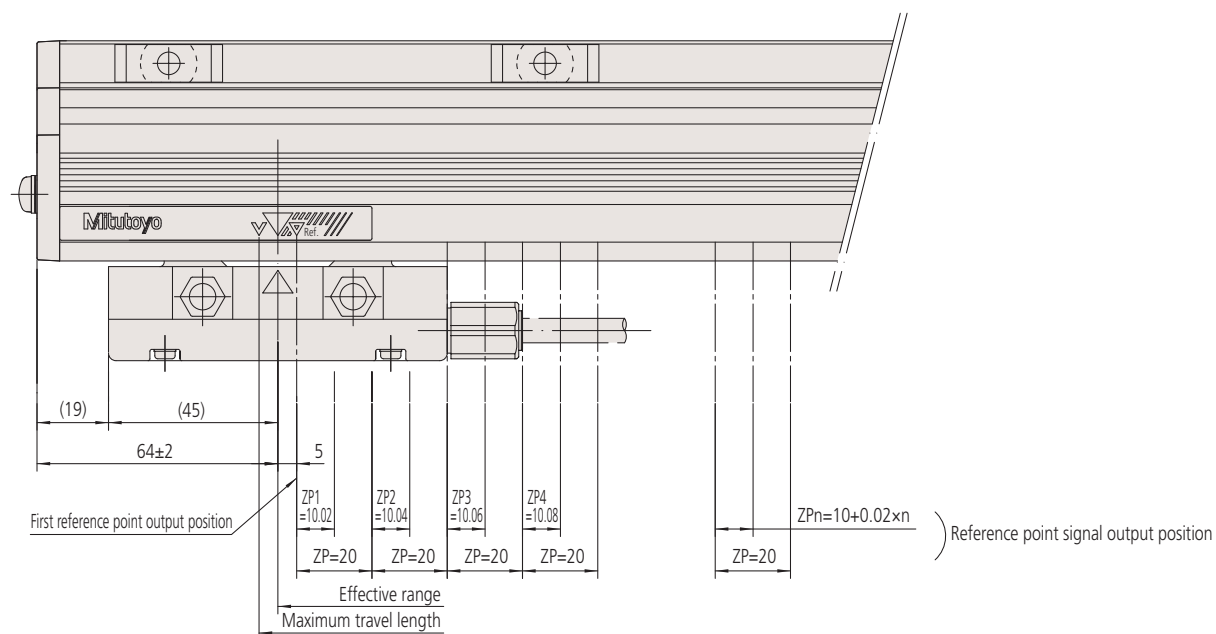

AT402E scale unit mounting dimensions

Assembly Type AT Series
AT402E

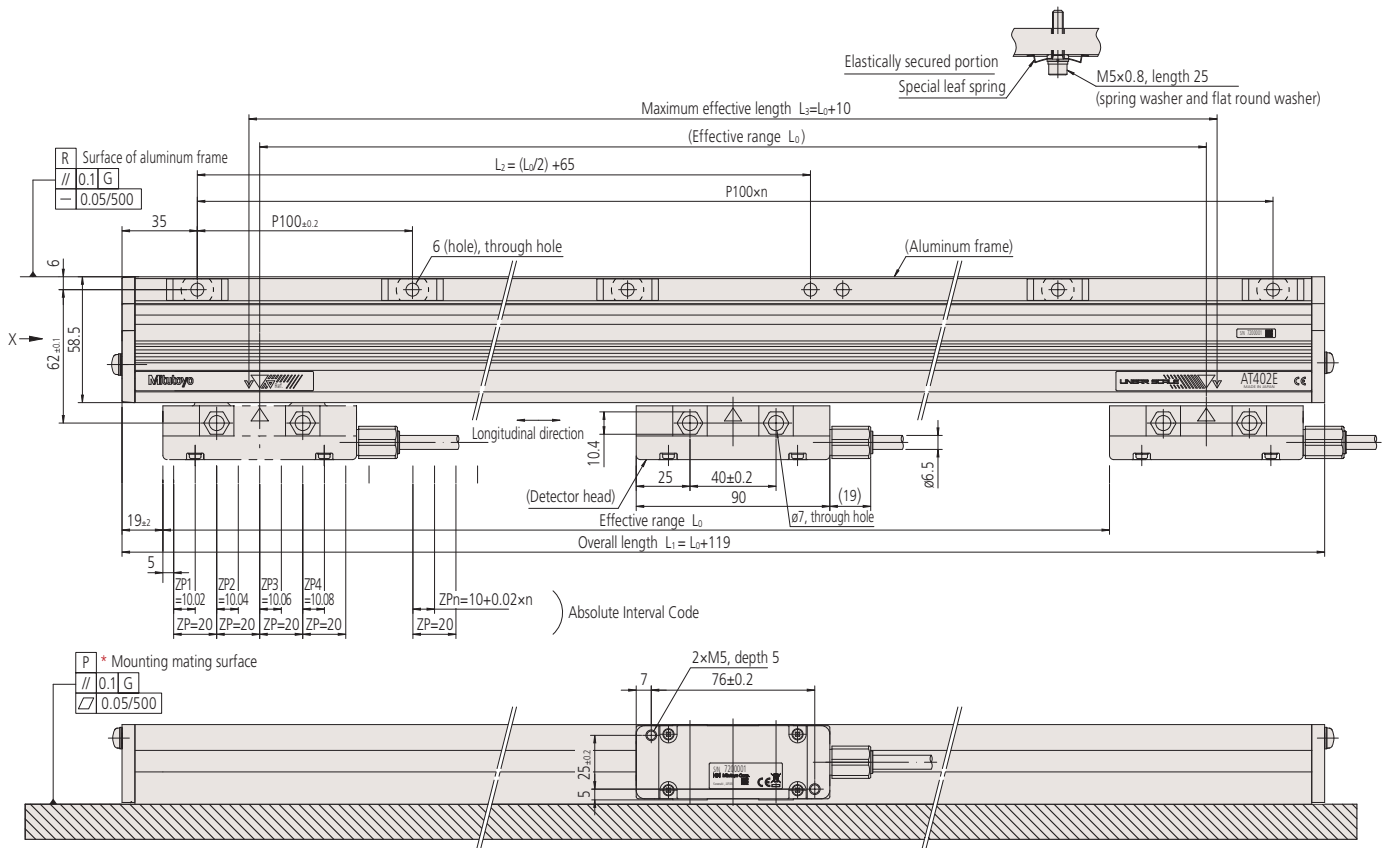

[Notes]

1. G indicates the machine guideway.
2. P indicates the mating surface for mounting the aluminum frame. S indicates the mating surface for mounting the detector head.
3. Q and R indicate the datum surfaces for mounting this linear scale.

View from X direction

Mounting example 1

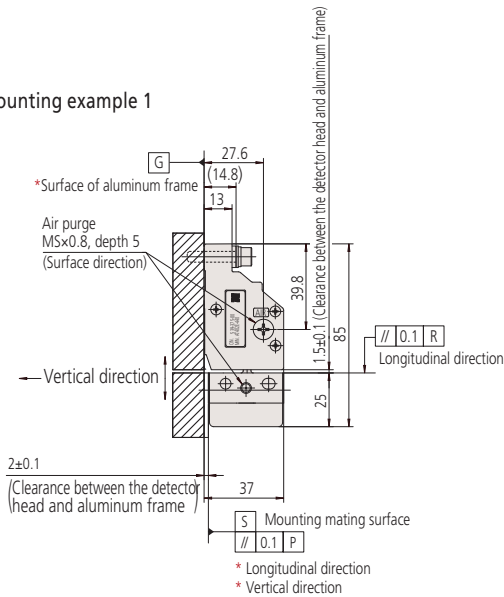

Mounting example 2

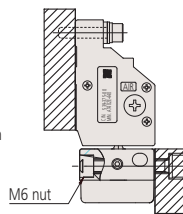

Mounting example 3

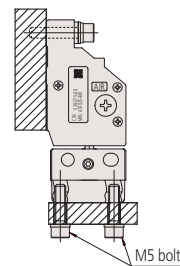

Dimensions of scale units

Code	Effective range L ₀ (mm)	Overall length L ₁ (mm)	L ₂ (mm)	Maximum travel length L ₃ (mm)	n (pcs)
AT402E-140	140	259	135	150	2
AT402E-240	240	359	185	250	3
AT402E-340	340	459	235	350	4
AT402E-440	440	559	285	450	5
AT402E-540	540	659	335	550	6
AT402E-640	640	759	358	650	7
AT402E-740	740	859	435	750	8
AT402E-840	840	985	485	850	9
AT402E-940	940	1059	535	950	10
AT402E-1040	1040	1159	585	1050	11
AT402E-1140	1140	1259	635	1150	12
AT402E-1240	1240	1359	685	1250	13
AT402E-1340	1340	1459	735	1350	14
AT402E-1440	1440	1559	785	1450	15
AT402E-1540	1540	1659	835	1550	16
AT402E-1640	1640	1759	885	1650	17
AT402E-1740	1740	1859	935	1750	18
AT402E-1840	1840	1959	985	1850	19
AT402E-2040	2040	2159	1085	2050	21
AT402E-2240	2240	2359	1185	2250	23
AT402E-2440	2440	2559	1285	2450	25
AT402E-2640	2640	2759	1385	2650	27
AT402E-2840	2840	2959	1485	2850	29
AT402E-3040	3040	3159	1585	3050	31

Codes and Order Numbers

Code	Scale unit + single wire cable 3m (A Type)	Scale unit + cable with European CNC manufacturer's connector 3m (B Type)	Scale unit + Cable with FANUC LTD. connector 3m (C Type)
	Order No.	Order No.	Order No.
AT402E-140	539-371-01	539-371-02	539-371-03
AT402E-240	539-373-01	539-373-02	539-373-03
AT402E-340	539-374-01	539-374-02	539-374-03
AT402E-440	539-375-01	539-375-02	539-375-03
AT402E-540	539-376-01	539-376-02	539-376-03
AT402E-640	539-377-01	539-377-02	539-377-03
AT402E-740	539-378-01	539-378-02	539-378-03
AT402E-840	539-379-01	539-379-02	539-379-03
AT402E-940	539-380-01	539-380-02	539-380-03
AT402E-1040	539-381-01	539-381-02	539-381-03
AT402E-1140	539-382-01	539-382-02	539-382-03
AT402E-1240	539-383-01	539-383-02	539-383-03
AT402E-1340	539-384-01	539-384-02	539-384-03
AT402E-1440	539-385-01	539-385-02	539-385-03
AT402E-1540	539-386-01	539-386-02	539-386-03
AT402E-1640	539-387-01	539-387-02	539-387-03
AT402E-1740	539-388-01	539-388-02	539-388-03
AT402E-1840	539-389-01	539-389-02	539-389-03
AT402E-2040	539-390-01	539-390-02	539-390-03
AT402E-2240	539-391-01	539-391-02	539-391-03
AT402E-2440	539-392-01	539-392-02	539-392-03
AT402E-2640	539-393-01	539-393-02	539-393-03
AT402E-2840	539-394-01	539-394-02	539-394-03
AT402E-3040	539-395-01	539-395-02	539-395-03

Assembly Type AT Series

Square-Wave Signal Output Type Scale Unit (Slim/High-speed types)

AT211

Mounting method: Multi-point fixing (excellent vibration and shock resistance)

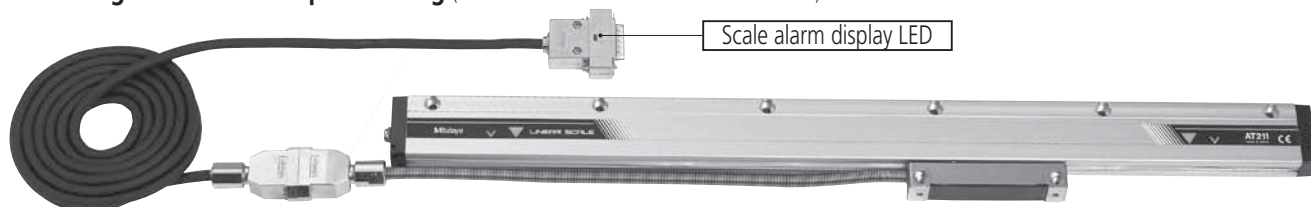

Mounting method: Double-end fixing (space-saving type)



Features

- This is a slim, sealed scale that can be directly connected to the control unit.
- High speed response up to 120m/min, making it compatible with a wide range of resolutions from 0.1 to 5 μ m.
- The multi-point fixing type has excellent vibration resistance.
- Scale alarm display makes for easy maintenance.
- Wide range of specifications enables easy choice to best suit your application.

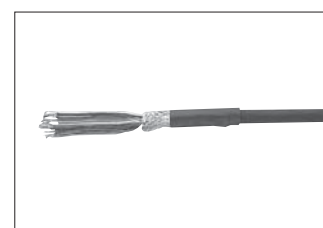

Single head cable type (no connector)

Specifications

Item	Code	AT211
Effective range (L _o)		100, 150, 200, 250, 300, 350, 400, 450, 500, 600, 700, 750, 800, 900, 1000, 1100, 1200, 1300, 1400, 1500 mm
Scale reference point		50mm pitch, center point, left end, right end (fixed when shipped)
Accuracy (20°C)		(3+3L _o /1000) μ m (For L _o 500mm, we can also fabricate a high-accuracy type: (2+2L _o /1000) μ m) L _o : Effective range (mm)
Vibration resistance		200 m/s ² (Conditions: 55 to 2000Hz) (Multi-point fixing type)
Shock resistance		250 m/s ² (Conditions: half-sine, 11ms) (Multi-point fixing type)
Air supply hole		With air supply hole (Multi-point fixing type)
Output signal	Type	PA/P \bar{A} , PB/P \bar{B} , PZ/P \bar{Z}
	Electrical specifications	Conforms to RS422
Main scale grating pitch		20 μ m
Minimum resolution		0.1, 0.2, 0.5, 1, 2.5, 5 μ m (fixed when shipped)
Minimum edge interval		125, 250, 333, 500, 1000ns (fixed when shipped)
Maximum response speed		5.4 to 120 m/min (Determined by minimum resolution and minimum edge interval)
Power supply voltage		5VDC \pm 5%
Maximum current consumption		200 mA
Protection rating		Equivalent to IP53 (when the user's manual is followed)
Sliding force		5N max.
Operating temperature		0 to 45°C
Storage temperature		-20 to 70°C
Operating/storage humidity		20 to 80%RH (no condensation)
Direction switching		Standard/Reverse (set when shipped)
Alarm function	Alarm detection	Over-speed, scale signal error
	Alarm output	Output for PA/P \bar{A} , PB/P \bar{B} , and PZ/P \bar{Z} are all high-impedance
	Alarm display	Red LED on NC side connector of signal cable turns on (this does not include single head cable types)

Mounting dimensions for multi-point fixing type

Unit: mm

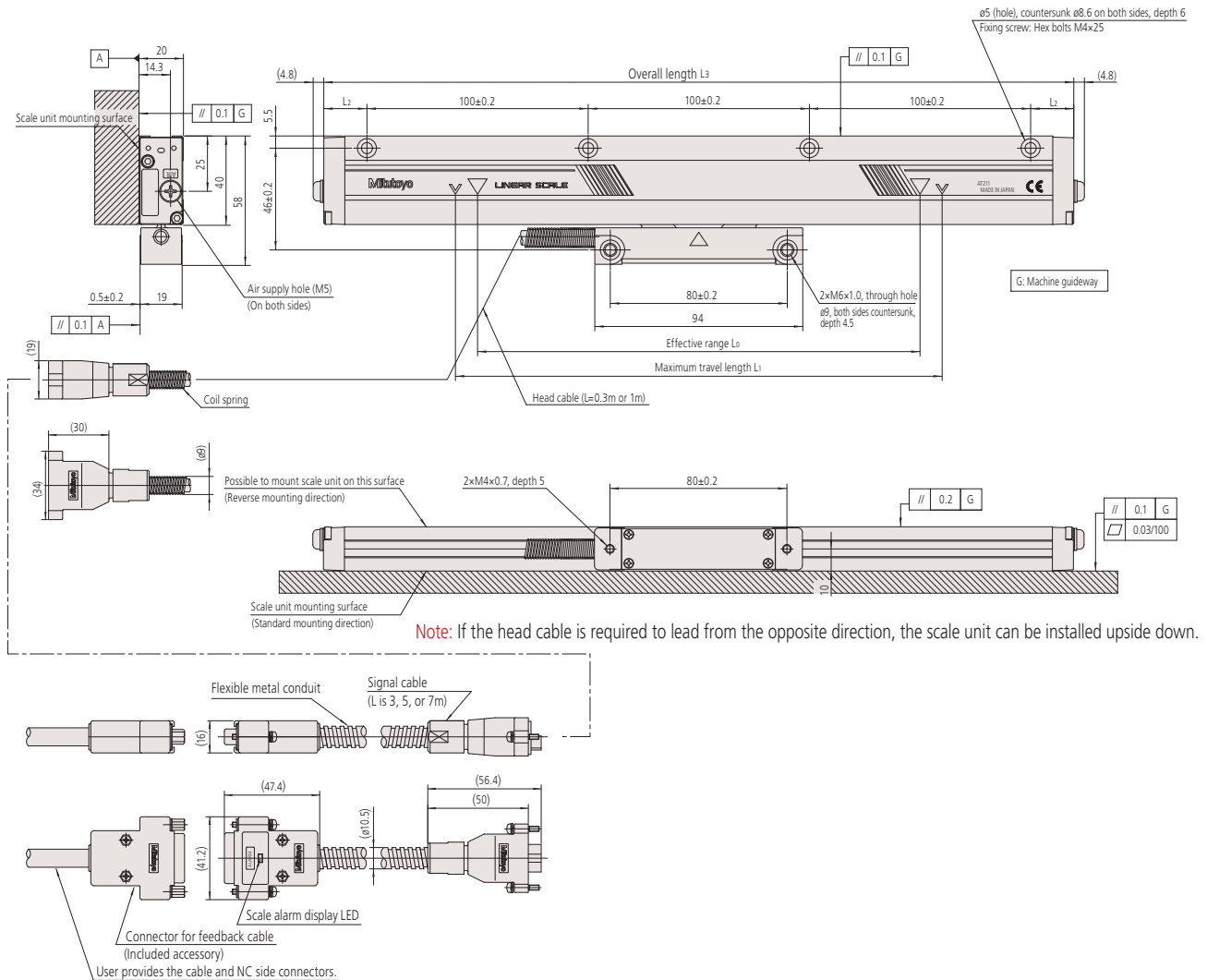

Mounting dimensions for multi-point fixing type

Scale unit	Effective range L_0 (mm)	Maximum travel length L_1 (mm)	End surface dimensions L_2 (mm)	Overall length L_3 (mm)	No. of mounting holes on scale unit (pcs)
AT211- 100A	100	120	19.5	239	3
AT211- 150A	150	170	44.5	289	3
AT211- 200A	200	220	19.5	339	4
AT211- 250A	250	270	44.5	389	4
AT211- 300A	300	330	24.5	449	5
AT211- 350A	350	380	49.5	499	5
AT211- 400A	400	430	24.5	549	6
AT211- 450A	450	480	49.5	599	6
AT211- 500A	500	540	29.5	659	7
AT211- 600A	600	640	29.5	759	8
AT211- 700A	700	740	29.5	859	9
AT211- 750A	750	780	49.5	899	9
AT211- 800A	800	840	29.5	959	10
AT211- 900A	900	940	29.5	1059	11
AT211-1000A	1000	1040	29.5	1159	12
AT211-1100A	1100	1140	29.5	1259	13
AT211-1200A	1200	1240	29.5	1359	14
AT211-1300A	1300	1340	29.5	1459	15
AT211-1400A	1400	1440	29.5	1559	16
AT211-1500A	1500	1540	29.5	1659	17

Mounting dimensions for double-end fixing type

Unit: mm

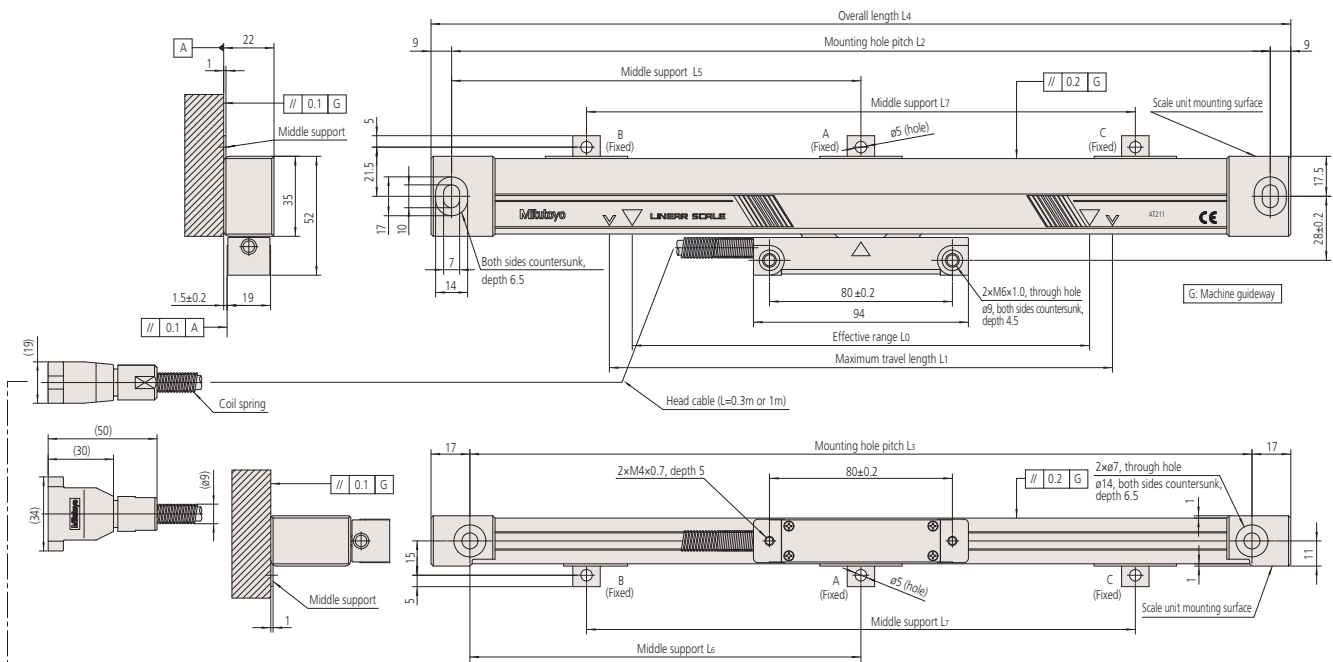

Note: If the head cable is required to lead from the opposite direction, the scale unit can be installed upside down.

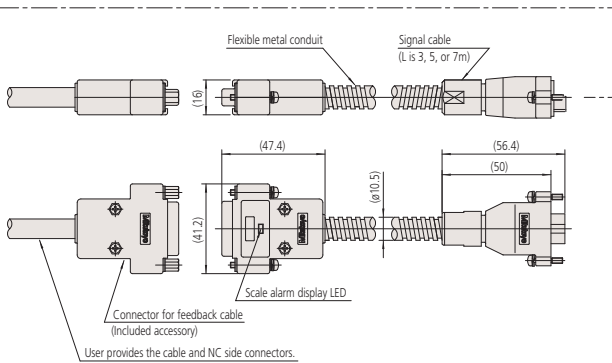

User provides the cable and NC side connectors.

Mounting dimensions for double-end fixing type

Scale unit	Effective range L ₀ (mm)	Maximum travel length L ₁ (mm)	Mounting hole pitch (mm)		Overall length L ₄ (mm)	Middle support (mm)		
			L ₂ (mm)	L ₃ (mm)		L ₅	L ₆	L ₇
AT211- 100B	100	120	258	242	276			
AT211- 150B	150	170	308	292	326			
AT211- 200B	200	220	358	342	376			
AT211- 250B	250	270	408	392	426			
AT211- 300B	300	330	468	452	486			
AT211- 350B	350	380	518	502	536			
AT211- 400B	400	430	568	552	586			
AT211- 450B	450	480	618	602	636			
AT211- 500B	500	540	678	662	696	339	331	
AT211- 600B	600	640	778	762	796	389	381	
AT211- 700B	700	740	878	862	896	439	431	
AT211- 750B	750	780	918	902	936	459	451	
AT211- 800B	800	840	978	962	996	489	481	
AT211- 900B	900	940	1078	1062	1096	539	531	
AT211-1000B	1000	1040	1178	1162	1196	589	581	
AT211-1100B	1100	1140	1278	1262	1296			430
AT211-1200B	1200	1240	1378	1362	1396			460
AT211-1300B	1300	1340	1478	1462	1496			490
AT211-1400B	1400	1440	1578	1562	1596			530
AT211-1500B	1500	1540	1678	1662	1696			560

- The number of middle supports attached depends on the effective range.

Effective range (mm)	Middle support
500 to 1000	A (1 place)
1100 to 1500	B, C (2 places)

Cable pattern

Unit: mm

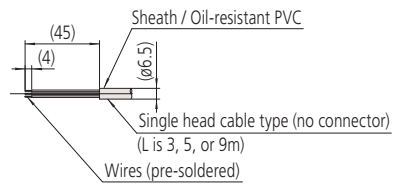
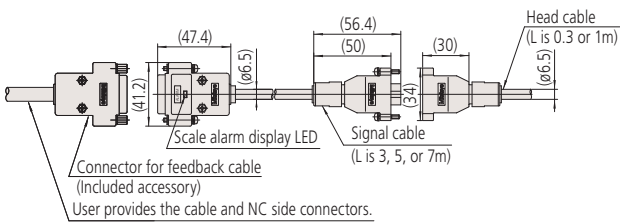
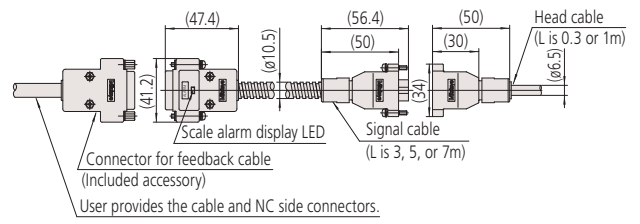
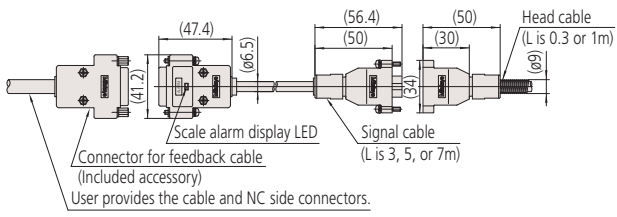

Specification Selection Method

- There is an extensive selection of specifications for the AT211.
 - Choose the appropriate numbers and letters below according to specification required.
- If you don't have a specification in mind, choose the option with the ●.
- * For special applications not shown in the specifications, please contact us. Additionally, we are also able to meet the IVP-P Sinusoidal signal output specification.

How to read the code

AT211 - [] - [] - []

Effective range list

Code	Effective range (mm)	Code	Effective range (mm)	Code	Effective range (mm)
0100	100	0450	450	1000	1000
0150	150	0500	500	1100	1100
0200	200	0600	600	1200	1200
0250	250	0700	700	1300	1300
0300	300	0750	750	1400	1400
0350	350	0800	800	1500	1500
0400	400	0900	900		

Mounting method

Code	
A	Multi-point fixing
B	Double-end fixing

Scale reference point

Code	
● 1	50mm pitch
2	Center point
3	Left end
4	Right end

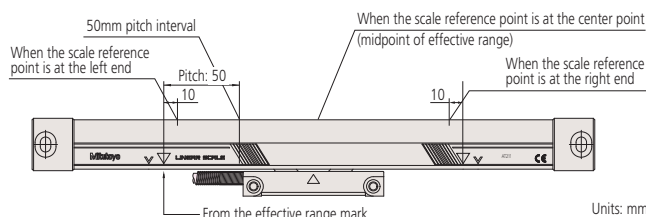

Accuracy (20°C)

Code	
● S	$(3+3L_0/1000) \mu\text{m}$
H	$(2+2L_0/1000) \mu\text{m}$

Note 1: L_0 is the effective range (mm).

Note 2: Type H is used for effective ranges of 500mm or less.

Specification combination table (resolution, response speed, and minimum edge interval)

Resolution (μm)	Minimum edge interval (ns)*				
	125	250	333	500	1000
0.1	A: 43 (710)	B: 22 (360)	C: 16 (260)	D: 11 (180)	E: 5.4 (90)
0.2	F: 86 (1400)	G: 43 (710)	H: 32 (530)	J: 22 (360)	K: 11 (180)
0.5	L: 120 (2000)	M: 110 (1800)	N: 81 (1300)	P: 54 (900)	Q: 27 (450)
1.0	—	R: 120 (2000)	S: 120 (2000)	T: 110 (1800)	U: 54 (900)
2.5	—	—	—	W: 120 (2000)	X: 120 (2000)
5.0	—	—	—	—	Y: 120 (2000)

* Codes A to Y show the maximum response speed in m/min, values in () are mm/s.

Note: The minimum edge interval varies 0 to -10% based on the operating environmental conditions.

(Example)

AT211 - 1500A1S - P1 - AB

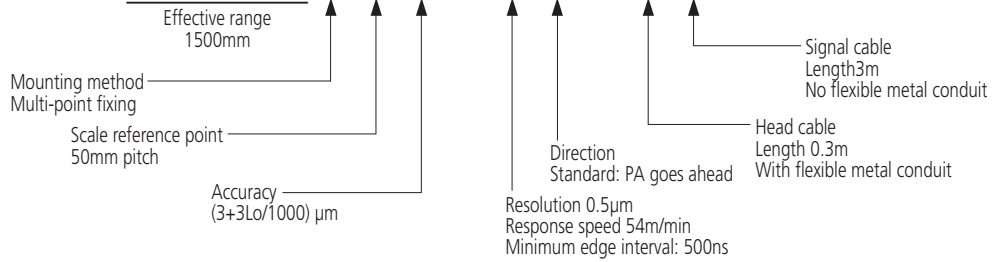

Signal cable

Code	Length (L)	Flexible metal conduit*1
● A	3m	Yes
B	3m	No
C	5m	Yes
D	5m	No
E	7m	Yes
F	7m	No
G*2	3m	No
H*2	5m	No
J*2	7m	No
X	No signal cable	

*1 The cable is enclosed in a flexible metal conduit or else is PVC sheathed.
*2 The connector (CN3) for signal cables G, H, and J are half-pitch connectors.

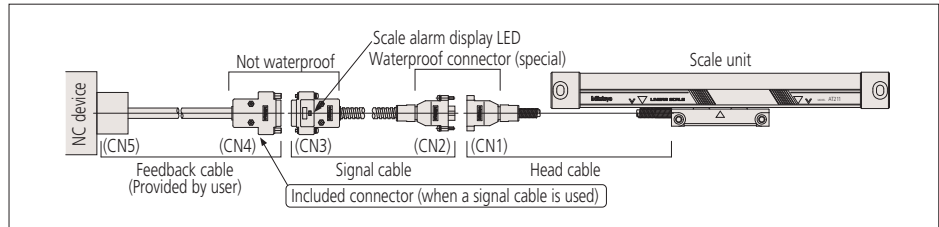

Connector for signal cable (CN3) (pin type)

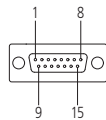

Pin No.	Signal	Pin No.	Signal
1, 2, 13	0V	8	PB
3, 4, 11	+5V	9	PZ
5	PA	10	PZ
6	PA	12, 14	Not used
7	PB	15	F.G

Applicable connector (CN4):
HDAB-15S (Hirose Electric or equivalent product (D-sub series) may be used)

Output circuit specification

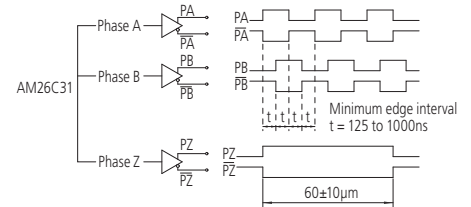

Head cable

Code	Length (L)	Flexible metal conduit	Connector (CN1)
● A	0.3m	Yes	Special waterproof
B	0.3m	No	Special waterproof
C	1m	No	Special waterproof
D	3m	No	No
E	4m		
F	5m		
H	7m		
J	8m		
K	9m		

Note: The cable is enclosed in a flexible metal conduit or else is PVC sheathed.

Single head cable type (no connector)

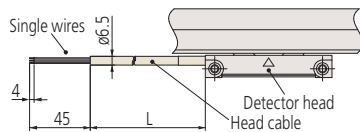

ALM signal for single head cable type (no connector)

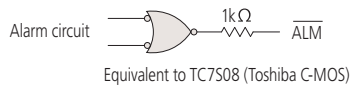

Equivalent to TC7S08 (Toshiba C-MOS)



Wire color	Signal	Wire color	Signal
White, black	0V	Blue	PB
Brown, red	+5V	Purple	PZ
Orange	PA	Gray	PZ
Yellow	PA	Pink	ALM
Green	PB		

Direction

Code	
● 1	Standard: PA goes ahead
2	Reverse: PB goes ahead

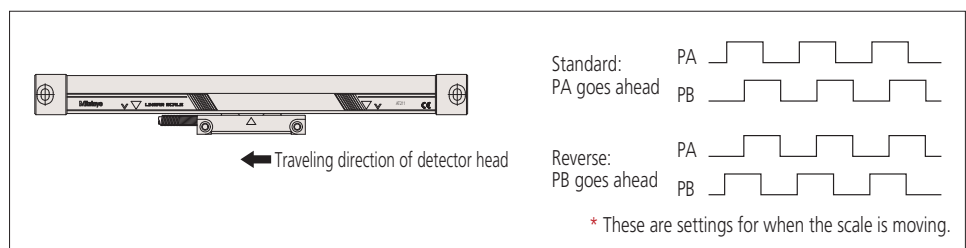

* These are settings for when the scale is moving.

Assembly Type AT Series

Square Wave Signal Output Type Scale Unit (Standard type)

AT203



Features

- The maximum effective measurement length of 6000mm enables use on large machines (such as for LCD production).
- The travel length of the linear scale is output with 2-phase square wave signals, which can be used as a feedback signal for NC machine tools.
- The pulse signal unit (PSU) is no longer needed, and the AT203 can be directly connected to the NC machine tool.
- The maximum response speed is 2000mm/s. (When resolution is 1μm and the minimum edge interval is 250ns)

Specifications

Item	Code	AT203
Detection method		Photoelectric type transmission linear encoder
Output		Two 90° phase-shifted square wave signals
Output method		Differential line driver
Signal output pitch		20μm
Resolution		1, 0.5, 0.1μm (switched using DIP switches)
Effective range		100 to 6000mm
Accuracy (20°C)		Effective range 100 to 1500mm (3+3L ₀ /1000) μm Effective range 1600 to 3000mm (5+5L ₀ /1000) μm Effective range 3250 to 6000mm (5+8L ₀ /1000) μm L ₀ : Effective range (mm)
Maximum response speed		11 to 120m/min (Depends on the resolution and minimum edge interval) (See separate table)
Scale reference point pitch		50mm
Main scale thermal expansion coefficient		(8±1) ×10 ⁻⁶ /°C
Power supply voltage		5VDC±5%
Maximum current consumption		250mA
Operating/storage temperature		0 to 45°C, -20 to 70°C (no condensation)
Operating/storage humidity (relative humidity)		20 to 80% RH (no condensation)
Protection rating		Equivalent to IP53
Sliding force		5N max.

Signal cable 3m (optional accessory) **Part No.09AAA353B**

Signal cable 5m (included accessory) **Part No.09AAA353A**

Pin assignment

Pin No.	Function
1	0V
2	0V
3	+5V
4	+5V
5	PA
6	PĀ
7	PB
8	PB̄
9	PZ
10	PZ
11	+5V
12	N.C.
13	0V
14	N.C.
15	F.G

Connector used: HDAB-15P (Hirose Electric)

Applicable selectable: HDAB-15S (Hirose Electric)

Output signal waveform

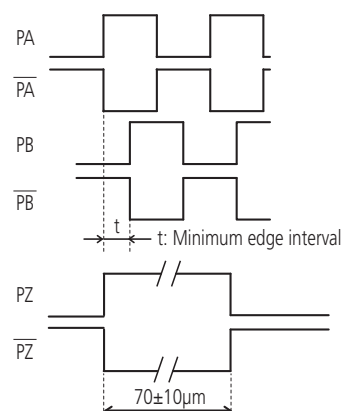

Maximum response speed*

Minimum edge interval	Resolution	Maximum response speed (m/min)		
		1 μm	0.5 μm	0.1 μm
500ns		★110 (50)	54 (50)	11 (11)
250ns		120 (50)	110 (50)	22 (22)

The ★ indicates the setting when shipped

* Values in () are for effective ranges of 3250mm and more.

* The minimum edge interval varies 0 to -10% based on the operating environmental conditions.

Direction

Internal DIP switches can be used to switch between the standard and reverse directions.

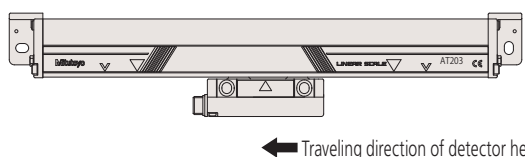

Standard:
PA goes ahead

Reverse:
PB goes ahead

* This is in the standard direction when shipped.

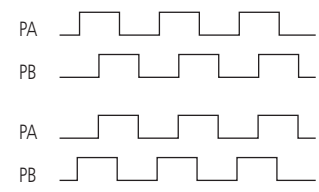

Wiring example

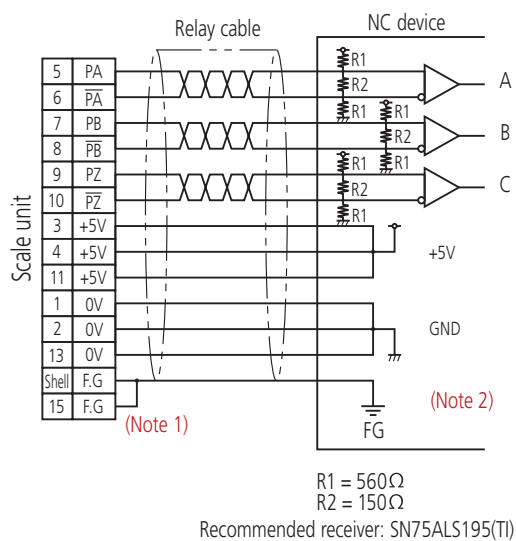

Note 1: When the shield has a drain wire, connect it to Pin 15.

Note 2: Always ground the shield for relay cables by, for example, connecting it to an earth conductor.

AT203 scale unit mounting dimensions

• AT203-100 to 3000

Unit: mm

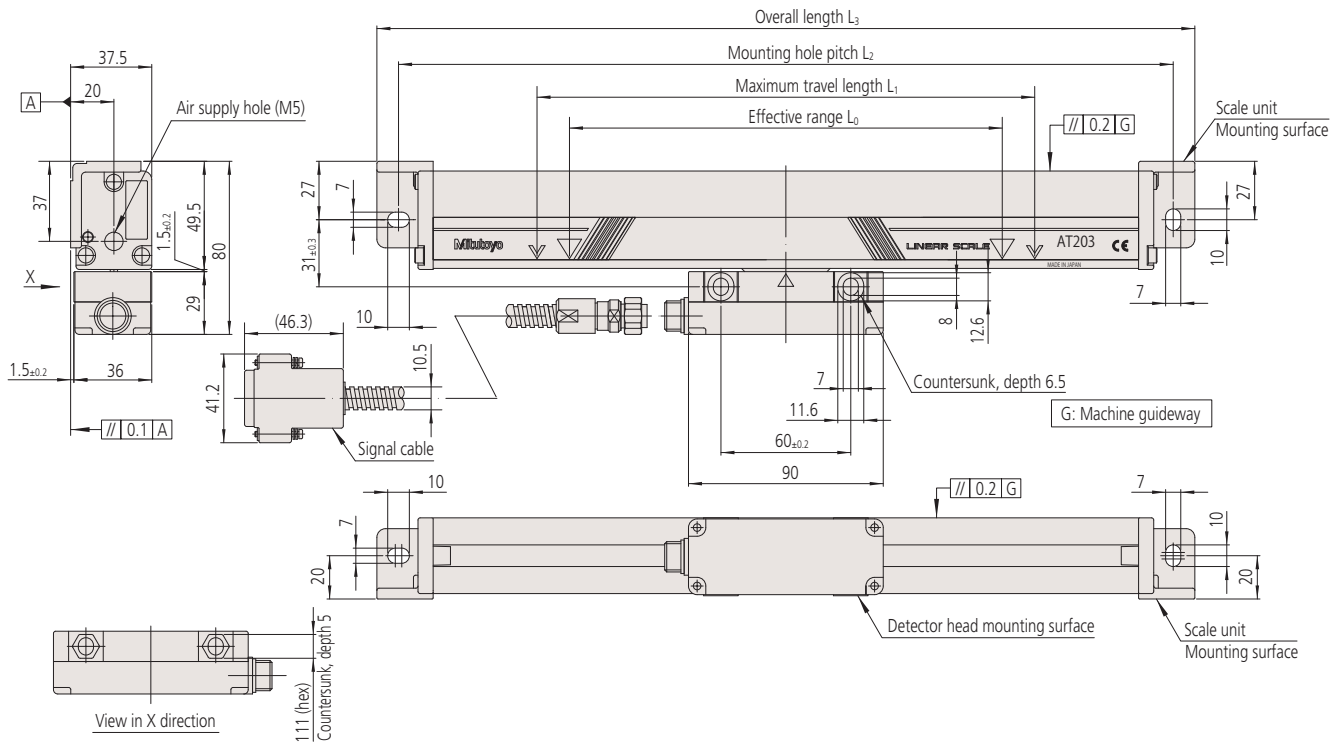

Order No.	Code	Effective range L ₀ (mm)	Maximum travel length L ₁ (mm)	Mounting hole pitch L ₂ (mm)	Overall length L ₃ (mm)	L ₄ (mm)	L ₅ (mm)	L ₆ (mm)
539-411-30	AT203-100	100	120	248	268			
539-412-30	AT203-150	150	170	298	318			
539-413-30	AT203-200	200	220	348	368			
539-414-30	AT203-250	250	270	398	418			
539-415-30	AT203-300	300	330	458	478			
539-416-30	AT203-350	350	380	508	528			
539-417-30	AT203-400	400	430	558	578			
539-418-30	AT203-450	450	480	608	628			
539-419-30	AT203-500	500	540	668	688			
539-421-30	AT203-600	600	650	778	798			
539-423-30	AT203-700	700	760	888	908			
539-424-30	AT203-750	750	810	938	958			
539-425-30	AT203-800	800	860	988	1008			
539-426-30	AT203-900	900	960	1088	1108			
539-427-30	AT203-1000	1000	1060	1188	1208	594		
539-428-30	AT203-1100	1100	1160	1288	1308	644		
539-429-30	AT203-1200	1200	1260	1388	1408	694		
539-430-30	AT203-1300	1300	1360	1488	1508	744		
539-431-30	AT203-1400	1400	1460	1588	1608	794		
539-432-30	AT203-1500	1500	1560	1688	1708	844		
539-433-30	AT203-1600	1600	1690	1818	1838		610	
539-434-30	AT203-1700	1700	1790	1918	1938		650	
539-435-30	AT203-1800	1800	1890	2018	2038		670	
539-436-30	AT203-2000	2000	2100	2228	2248		740	
539-437-30	AT203-2200	2200	2300	2428	2448		800	
539-438-30	AT203-2400	2400	2500	2628	2648	1314	1300	650
539-439-30	AT203-2500	2500	2600	2728	2748	1364	1340	670
539-440-30	AT203-2600	2600	2700	2828	2848	1414	1400	700
539-441-30	AT203-2800	2800	2900	3028	3048	1514	1500	750
539-442-30	AT203-3000	3000	3100	3228	3248	1614	1600	800

• AT203-100 to 3000

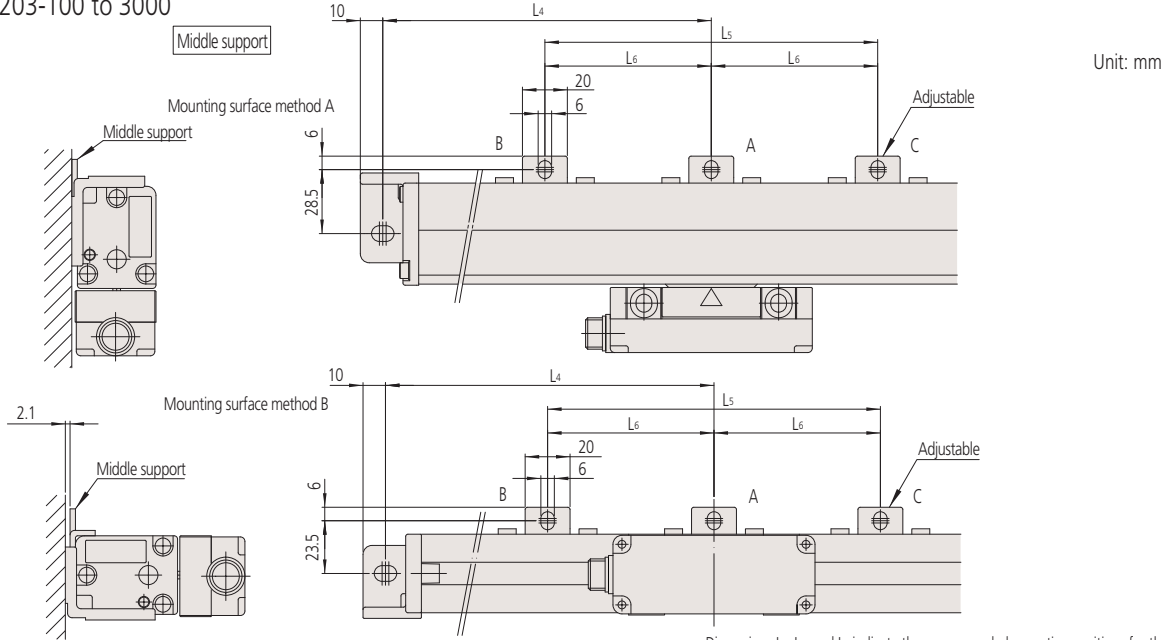

Unit: mm

• Dimensions L₄, L₅, and L₆ indicate the recommended mounting positions for the middle supports included with scale units with an effective range of 1000mm and more. (The position of the middle support is adjustable in the measuring direction.)

Effective range (mm)	Middle support
1000 to 1500	A (1 place)
1600 to 2200	B, C (2 places)
2400 to 3000	A, B, C (3 places)

• AT203-3250 to 6000

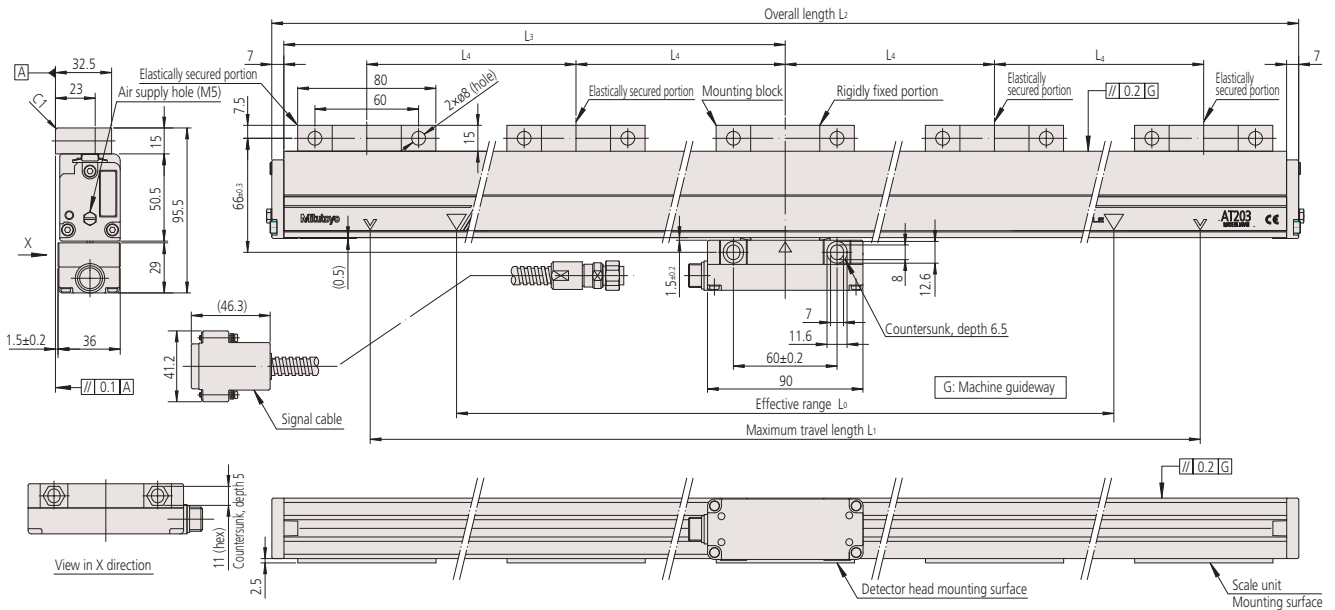

Order No.	Code	Effective range L ₀ (mm)	Maximum travel length L ₁ (mm)	Overall length L ₂ (mm)	L ₃ (mm)	L ₄ (mm)	No. of mounting blocks
539-443-30	AT203-3250	3250	3350	3464	1725	800	5
539-444-30	AT203-3500	3500	3600	3714	1850	850	
539-445-30	AT203-3750	3750	3850	3964	1975	930	
539-446-30	AT203-4000	4000	4100	4214	2100	1000	
539-447-30	AT203-4250	4250	4350	4464	2225	1050	
539-448-30	AT203-4500	4500	4600	4714	2350	1100	
539-449-30	AT203-4750	4750	4850	4964	2475	800	
539-450-30	AT203-5000	5000	5100	5214	2600	830	7
539-451-30	AT203-5250	5250	5350	5464	2725	870	
539-452-30	AT203-5500	5500	5600	5714	2850	910	
539-453-30	AT203-5750	5750	5850	5964	2975	950	
539-454-30	AT203-6000	6000	6100	6214	3100	1000	

Interface Unit

Pulse signal conversion unit

PSU-200

- The PSU-200 splits the sinusoidal signal output by Mitutoyo linear scales into a minimum of four and a maximum of 200 divisions, and converts the signal to a square wave signal so that NC feedback systems, measurement control devices, etc., can be used with linear scales in order to achieve highly accurate positioning.



System configuration

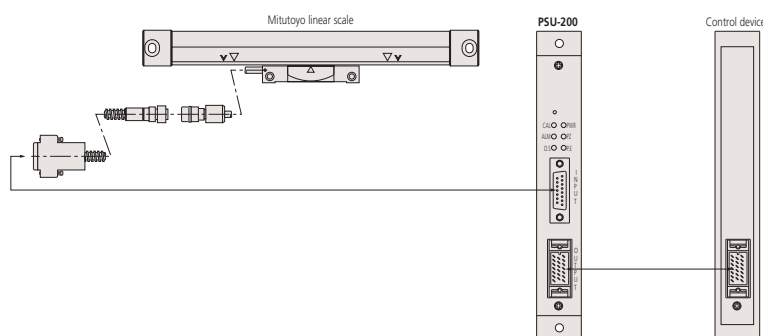

Connector and indicator functions

No.	Name	Function
(1)	CAL light	Typically not used
(2)	ALM light	Turns on when broken wires or short circuits are detected, or when a signal abnormality is detected.
(3)	O.S. light	Turns on when over-speed is detected.
(4)	PWR light	Turns on only when power is supplied to the PSU. Power is supplied at 5VDC, from an external device.
(5)	PZ light	Turns on when the scale goes past the reference point.
(6)	P.E. light	Turns on when the +5VDC power supply voltage from the external device decreases, or if noise is detected.
(7)	INPUT connector	For connecting to the linear scale.
(8)	OUTPUT connector	Output connector for connecting to an external device.

Dimensions

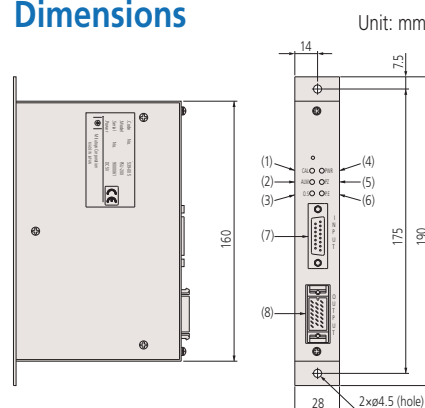

Specifications

Item	Details of function
Number of axes	1 axis
Input	Input connector DA-15S-NR (JAE) or equivalent Input signal: 2-phase sinusoidal signals and standard voltage Reference point signal, scale alarm signal
Output	Output connector MR-20RM (Honda Tsushin) Output signal: 2-phase square wave signals (Phase A, Phase B), reference point signal (Phase Z) Alarm signal, alarm reset signal, photocoupler
Number of divisions	4, 8, 10, 20, 40, 80, 100, 200 (chosen with switch)
Function	Setting the number of divisions, setting the minimum edge interval, and maximum response speed Detection of broken wires or short circuits and abnormalities (alarm), detection of signal errors (alarm) Power supply voltage low alarm (warning light only), switching between high-impedance mode and alarm signal output mode. Reference position detection light, hysteresis width settings (directly linked to No. of divisions), external alarm reset input (photocoupler), switching directions
Power supply	5VDC±5%
Current consumption	200mA
Storage temperature	-20°C to 70°C
Operating temperature	0°C to 50°C
Dimensions	Width 160mm x Thickness 28mm x Depth 100mm
Mass	Approx. 620g

Output specifications

Output connector (pin type)
 MR-20RM (Honda Tsushin Kogyo)
 Applicable plug
 Connector: MR20F (Honda Tsushin Kogyo)
 Case: MR-20L (Honda Tsushin Kogyo)
 Standard accessories

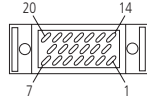

Pin No.	Signal	Signal function
1 to 3	0V	Signal GND
4 to 6	+5V	Power supply
7	ALM	Alarm output
8, 9	N.C	
10	RST (Anode)	Reset input
11	RST (Cathode)	
12, 13	N.C	
14	PZ	Phase Z output
15	PZ	
16	PA	Phase A output
17	PA	
18	PB	Phase B output
19	PB	
20	F.G	Frame GND

Setting	No. of divisions	Minimum edge interval	Maximum response speed (m/min)				Maximum input frequency (kHz)
			Scale pitch				
			4μm	10μm	20μm	40μm	
4	4	62.5ns	120	300	600	1200	500
		125 ns	120	300	600	1200	500
		250 ns	120	300	600	1200	500
		500 ns	120	300	600	1200	500
		1000 ns	60	150	300	600	250
8	8	62.5ns	120	300	600	1200	500
		125 ns	120	300	600	1200	500
		250 ns	120	300	600	1200	500
		500 ns	60	150	300	600	250
		1000 ns	30	75	150	300	125
10	10	62.5ns	120	300	600	1200	500
		125 ns	120	300	600	1200	500
		250 ns	96	240	480	960	400
		500 ns	48	120	240	480	200
		1000 ns	24	60	120	240	100
20	20	62.5ns	120	300	600	1200	500
		125 ns	96	240	480	960	400
		250 ns	48	120	240	480	200
		500 ns	24	60	120	240	100
		1000 ns	12	30	60	120	50
40	40	62.5ns	96	240	480	960	400
		125 ns	48	120	240	480	200
		250 ns	24	60	120	240	100
		500 ns	12	30	60	120	50
		1000 ns	6	15	30	60	25
80	80	62.5ns	48	120	240	480	200
		125 ns	24	60	120	240	100
		250 ns	12	30	60	120	50
		500 ns	6	15	30	60	25
		1000 ns	3	7.5	15	30	12.5
100	100	62.5ns	38.4	96	192	384	160
		125 ns	19.2	48	96	192	80
		250 ns	9.6	24	48	96	40
		500 ns	4.8	12	24	48	20
		1000 ns	2.4	6	12	24	10
200	200	62.5ns	19.2	48	96	192	80
		125 ns	9.6	24	48	96	40
		250 ns	4.8	12	24	48	20
		500 ns	2.4	6	12	24	10
		1000 ns	1.2	3	6	12	5

The maximum response speed is limited by the scale response speed.
 The minimum edge interval varies 0 to -10% based on the operating environmental conditions.

Arrangement of cable connections

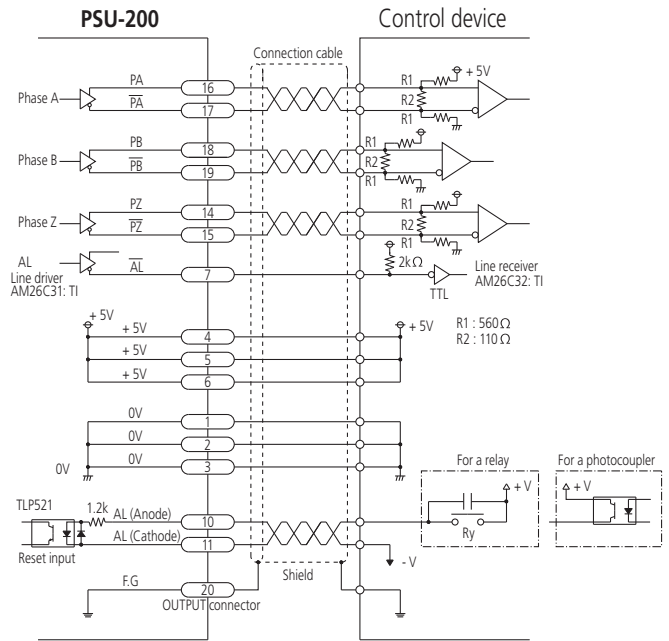

- Connect the alarm reset input circuit so that the current is 3 to 10mA. Also, the device has an internal resistor (1.2kΩ), so by applying 5 to 12V with a pulse width of at least 100ms across the AL (anode)-AL (cathode), the alarm can be reset. When applying 12V or more, add an external resistance to limit the current to within the range stated above.
- Connection of alarm reset input when using a photocoupler

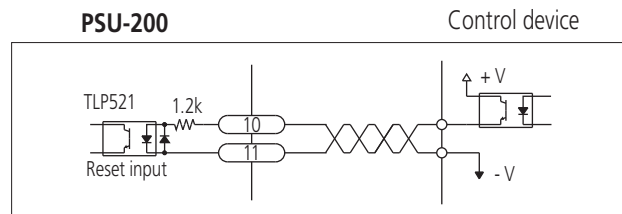

Interface Unit

Serial conversion unit

PSU-250 Series



- The PSU-250 series interface unit converts the sinusoidal signal output by Mitutoyo linear scales to a serial signal.
- The interface outputs serial data equivalent to 400 divisions from the signal (sinusoidal).
- The PSU-251 can be connected to Mitsubishi Electric Corporation's MR-J4/MR-J3 series servo amplifier.*1
- The PSU-252 can be connected to Panasonic Corporation, Motor business unit's MINAS series servo amplifier.*1

Connector and indicator functions

No.	Name	Function
(1)	INPUT connector	To connect the linear scale
(2)	OUTPUT connector	To connect the servo amplifier
(3)	Terminal block	Terminal block for input of 5VDC external power
(4)	Shorting link	Use when providing power from the servo amplifier. Do not use when not providing power from the servo amplifier
(5)	PWR light	Turns on when power is supplied to the PSU

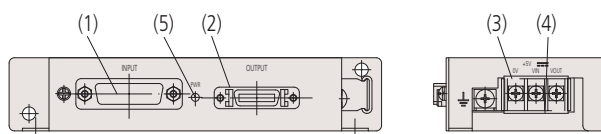

Specifications

Order No.	539-006	539-007
Item	PSU-251	PSU-252
Number of axes	1 axis	1 axis
Input specifications	2-phase sinusoidal signals and standard voltage, reference signal, scale alarm signal Maximum input frequency: 500kHz	
Output specifications	Mitsubishi Electric Corporation MR-J4/MR-J3 series High-speed serial data*1	Panasonic Corporation, Motor business unit MINAS-A5, A5L, A5N, A5NL series*1 MINAS-A4, A4P, A4N, A4NL series*1
Number of divisions	400 divisions	
Function	Alarm detection: Broken wires, short circuits in the scale and abnormalities. Alarm output: Status data is output through serial communication and the PWR light blinks Also, the PWR light turns on.	
Power supply	Power supply from the servo amplifier: 5VDC±5% External power supply: 5VDC±5% Power supply is selected with the shorting link for the terminal block used to supply external power. To choose a servo amplifier or external power supply, please refer to the servo amplifier power specifications (in particular, the maximum supplied current) and the power supply specifications of the scale that is used.	
Current consumption	150mA (not including the scale)	
Storage temperature	- 20°C to 70°C	
Operating temperature	0°C to 40°C	

*1 For details regarding the applicable system, please consult with the individual manufacturer.

Resolution and maximum response speed when the scale is connected

Scale model	Resolution	Maximum response speed
AT103	0.05 μm	2000mm/s (830mm/s)*2
AT113	0.05 μm	2000mm/s
AT112	0.05 μm	830mm/s
AT181	0.05 μm	830mm/s
ST36A	0.01 μm	1200mm/s
ST24C	0.025μm	1200mm/s
ST46	0.05 μm	2600mm/s
ST422	0.01 μm	5000mm/s

*2 Response speeds for effective ranges of 3250mm or more

System configuration

- When connecting an AT scale

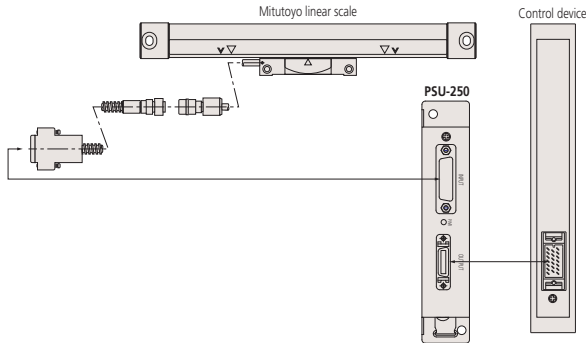

- When connecting an ST scale

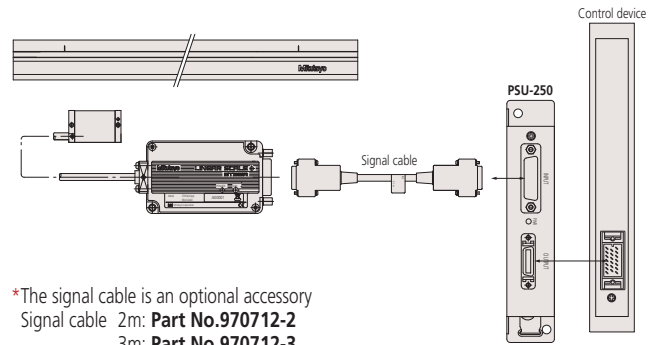

*The signal cable is an optional accessory
 Signal cable 2m: **Part No.970712-2**
 3m: **Part No.970712-3**
 5m: **Part No.970712-5**

Input specifications

- INPUT connector
- Connector (socket type): RDAD-15S-LNA (Hirose Electric)
- Applicable plug: HDAB-15P (Hirose Electric)

Pin No.	Signal	Signal function
1, 2	0V	Signal ground
3, 4	+5V	Power supply
5	PA	Phase A
6	PB	Phase B
7	Vref	Standard voltage
8	PZ	Phase Z
9	AL	Scale alarm
10 - 14	N.C	Not used
15	F.G	Frame ground

Output specifications

- OUTPUT connector
- Connector (socket type) 10220-52A2VC(3M)
- Applicable plug: 10120-3000VE(3M)

Pin No.	Signal	Signal function
1, 2, 11, 12	0V	Signal ground
18, 19, 20	+5V	+5V power
6, 8 - 10	N.C	Not used
7	RQ/DT	Standard phase request/data
17	RQ/DT	Reverse phase request/data
3	PA	Test signal
4	PB	Test signal
5	PZ	Test signal
13 - 16	N.C	Not used

- Terminal block for input of external power

Pin No.	Signal	Signal function
1	+5V OUT	+5V power output*
2	+5V IN	+5V power input*
3	0V	Signal ground
4	F.G	Frame ground

*When using the power supplied by the servo amplifier (supplied through output connector) short Pin Nos. 1 and 2 using the attached shorting link.

Dimensions

Unit: mm

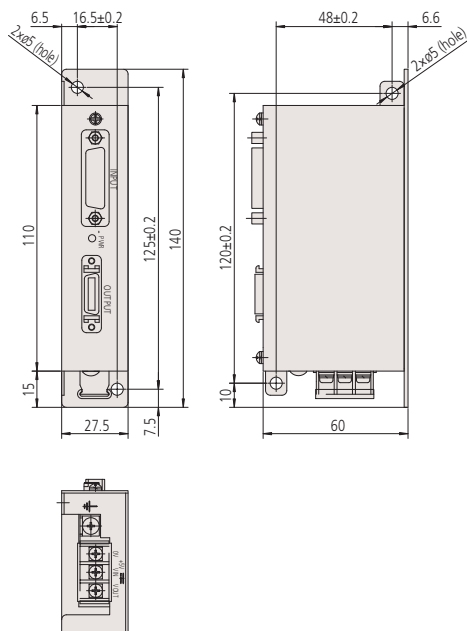

Absolute Scale Unit



Scale Format

Applicable Systems*1		Resolution		
		0.005μm*2	0.05μm	0.1μm
FANUC Ltd. NC control device	FS-i Series, POWER Mate i	ABS AT555	ABS AT553 ABS AT353	ABS ST758
Mitsubishi Electric Corporation MITSUBISHI CNC Series	Applicable amplifier: MDS-D/MDS-DH Series	ABS AT545	ABS AT543 ABS AT343	ABS ST748
Mitsubishi Electric Corporation MELSERVO Series	MR-J4/MR-J3 Series	ABS AT545A*3	ABS AT543 ABS AT343	ABS ST748A
Yaskawa Electric Corporation Σ-V, Σ-III Series	Servopack: SGDv, SGDS	—	—	ABS ST788A
Panasonic Corporation, Motor business unit MINAS Series	MINAS-A5, A5L, A5N, A5NL Series MINAS-A4, A4P, A4N, A4NL Series	—	ABS AT573A	ABS ST778A
Servo Amplifier supporting Mitutoyo ENSIS Interface	Nikki Denso Co., Ltd. VCII / VC / VPS Series	—	ABS AT503A ABS AT303A	ABS ST708A
	Servoland Corporation SVF Series			
	PMAC JAPAN Co., Ltd. UMAC-Turbo PMAC2			
	Other control device manufacturers	ABS AT505 ABS AT505A	ABS AT503 ABS AT303	

*1 For details regarding the applicable system, please consult with the individual manufacturer.

*2 For the AT300 series, 0.005μm resolution is possible to special order.

*3 Only for the MR-J4/MR-J3 series

Specifications

Series	Scale Type	Maximum effective range	Maximum response speed	Accuracy (20°C)*5
ABS ST700 Compact Type Series	Separate Type	6000mm	5m/s	(5+5L _o /1000) μm
ABS AT500 Series	Assembly Type	2200mm	2.5m/s	(3+3L _o /1000) μm
		1000mm	2.5m/s (1.2m/s*4)	(2+2L _o /1000) μm
		350mm		
ABS AT300 Series	Assembly Type	3000mm	2m/s (1.8m/s*4)	(3+3L _o /1000) μm However, at 1600mm (or greater) stroke is (5+5L _o /1000) μm

*4 Maximum response speed of 0.005μm resolution type

*5 L_o=effective range (mm); scale base type accuracy for the ST700 compact type series

Absolute system, linear scale principle (e.g. ABS AT500 Series, ABS AT300 Series)

[Figure 1]

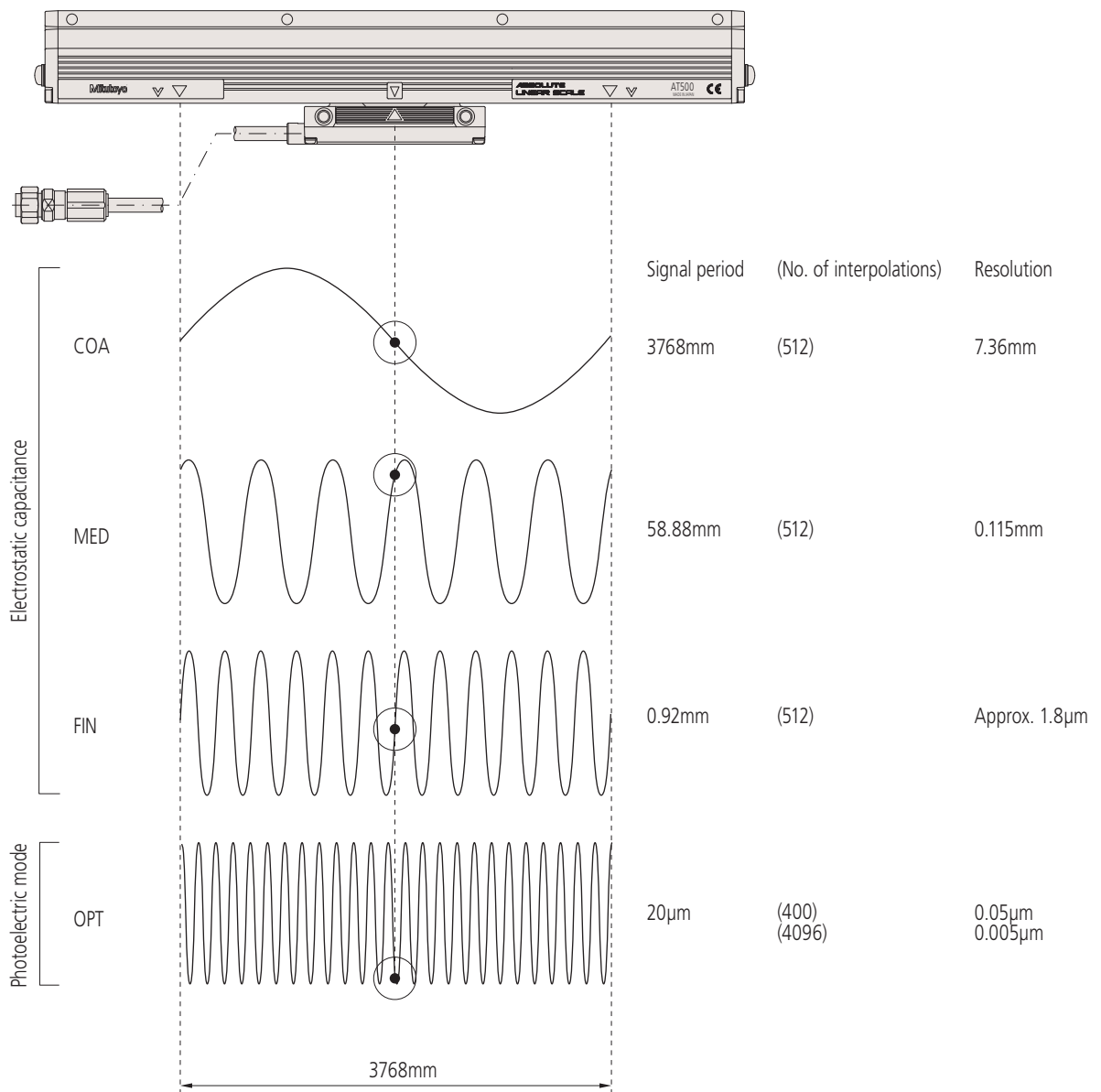

As shown in Figure1, when power is supplied to the linear scale the COA signal position is detected, and based on this the MED wavelength and position is detected.

In the same way, from the microprocessor that detects the FIN and OPT signal positions, an ultimate absolute value of resolution of 0.05µm/0.005µm is obtained.

Direction of absolute unit scale data increase

- ABS ST700 Compact Type Series

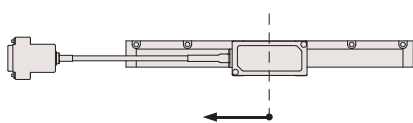

The data will increase when the detector moves in this direction.

- ABS AT500 Series

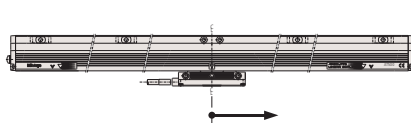

The data will increase when the detector moves in this direction.

- ABS AT300 Series

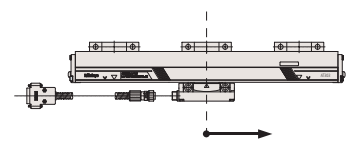

The data will increase when the detector moves in this direction.

Separate Type ABS ST Series

Absolute Scale Unit (High environmental resistance type)

ABS ST700 Compact Type Series

ABSOLUTE™

Features

- Absolute measurement with separate type scales
- Non-contact detection is optimal for high speed and high acceleration of linear motors, etc.
- Electromagnetic induction principle means scales are unaffected by contamination
- The detector head is approximately 1/3 the previous model size: 50mm (W) × 28mm (D) × 11mm (H)
- Cable outlets can be in four directions, with mounting holes on the top and sides
- Accuracy (5+5L/1000)μm (glass scale: (3+3L/1000)μm) is realized (previous models: (8+5L/1000) μm)
- *L: Effective range (mm)
- Compatible with servo amplifiers from a range of companies (high-speed serial interfaces)



How to read the code

ABS ST7 0 8 A L - 100 A - R

Absolute type

Series

Separate type Absolute linear scale

ABS ST700 compact type series (effective range ≤ 3m)

ABS ST700L compact type series (3.2m ≤ effective range ≤ 6m)

Interface specification*1

0: For Mitutoyo ENSIS high-speed serial

ABS ST708A, ST708AL

4: Mitsubishi Electric Corporation high-speed serial

ABS ST748A, ST748AL

ABS ST748, ST748L

5: FANUC Ltd. high-speed serial

ABS ST758, ST758L

7: Panasonic Corporation, Motor business unit high-speed serial

ABS ST778A, ST778AL

8: Yaskawa Electric Corporation high-speed serial

ABS ST788A, ST788AL

A: Scale base type

C: Glass scale type

Effective range: 100mm to 6000mm

Blank: 100mm to 3000mm

L: 3200mm to 6000mm

Head cable outlets

R: Right

L: Left

U: Up

D: Down

Communication method

A: 2 wire

Blank: 4 wire

Detector head shape and resolution

8: Shape 50mm (W) × 28mm (D) × 11mm (H)

Resolution 0.1μm

9: Resolution 0.05μm (special order)

Applicable interfaces

Applicable interfaces*1	FANUC Ltd. FS-i Series, POWER Mate i Series
	Mitsubishi Electric Corporation MELSERVO MR-J4/MR-J3 Series
	Mitsubishi Electric Corporation CNC Series MDS-D/MDS-DH Series
	Yaskawa Electric Corporation Σ-V Series, Σ-III Series
	Panasonic Corporation, Motor business unit MINAS-A5, A5L, A5N, A5NL Series, MINAS-A4, A4P, A4N, A4NL Series
Mitutoyo Corporation ENSIS*2	
Nikki Denso Co., Ltd. VC II/VC/VPS Series	
Servoland Corporation SVF Series	
PMAC JAPAN Co., Ltd. UMAC-Turbo PMAC2	

*1 For details (connectivity) regarding the applicable system, please consult with the individual manufacturer.

*2 ENSIS is a registered trademark of Mitutoyo Corporation.

Specifications

Item	Scale Type	Scale base type	Glass scale type
Resolution		0.1μm (0.05μm: special order)	
Detection method		Electromagnetic induction Absolute position detection method*	
Shape		Separate type scale	
Effective range (accuracy guarantee range)		100 to 3000mm / 3200 to 6000mm	100 to 1100mm
Accuracy (20°C)		(5+5L/1000) μm L: Effective range mm	(3+3L/1000) μm L: Effective range mm
Maximum feed speed		5 m/s	
Thermal expansion coefficient		(12.0±1.5) ×10 ⁻⁶ /°C (when attached to material equivalent to steel)	(8±1.0) ×10 ⁻⁶ /°C
Operating conditions	Temperature	0 to 50°C	
	Humidity	20 to 80%RH	
Storage conditions	Temperature	-20 to 70°C	
	Humidity	20 to 80%RH	
Power supply voltage		5V±10% (at the detector head) (Ripple and spike noise should not exceed 100mV)	
Current consumption		270mA (Max.)	
Vibration resistance		300m/s ² (55 to 2000Hz)	100m/s ² (55 to 2000Hz)
Shock resistance		500m/s ² (half-sine, 11ms)	150m/s ² (half-sine, 11ms)
Head cable	Length/cable diameter	1m / ø3.8mm (high-flex cable)	
	Connector	1) D-sub (15-pin pin type) connector (not waterproof) 2) D-sub (9-pin socket type) connector (not waterproof): for ST788A	
Maximum signal cable length		Up to 29m (head cable length included) (Please consult the user's manual)	
Detector mounting		1 location each on top and sides	
Direction of cable outlet		4 sides (top, bottom, left, right) can be selected	
EMC standard		CE mark standard	

Note: If considering using in an environment in which cutting fluid, etc., is used, please consult our nearest sales department.

System configuration

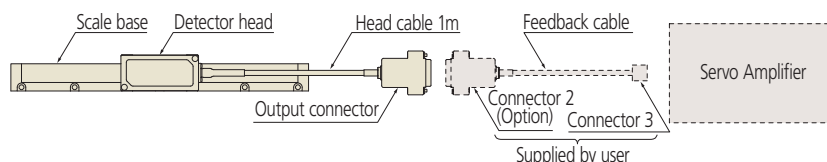

Feedback cable

Yaskawa Electric Corporation serial cable can be used as the feedback cable for connecting to the Yaskawa Electric Corporation servo amplifier.
Cable type number: JZSP-CLP70-□□E (03,05,10,15,20)

When wishing to connect a feedback cable to the Mitsubishi Electric Corporation MR-J4/MR-J3 series, please reference the code numbers below and order from our company.

For the MR-J4/MR-J3 series 5m: **No.06ACF117A**
10m: **No.06ACF117B**

Output specifications

• ST788A (L)

Output connector (socket type)
D-sub 9-pin
Applicable connector
17JE-23090-02 (D2C) (DDK)

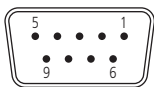

Alternately, an equivalent product (D-sub series) can be used

Pin No.	Signal
1	+5V (Vcc)
2	RQ/DT (S)
3	+5V (Vcc)
4	N.C
5	0V (GND)
6	RQ/DT (/S)
7	N.C
8	N.C
9	0V (GND)
Connector shell	F.G

Note: Leave test terminals (Pin No. 7 and 8) disconnected during use.

• ST748A (L), ST778A (L), ST708A (L)

Output connector (pin type)
D-sub 15-pin
Applicable connector
HDAB-15S (Hirose Electric)

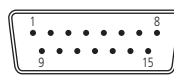

Alternately, an equivalent product (D-sub series) can be used

Pin No.	Signal
1	0V (GND)
2	0V (GND)
3	+5V
4	+5V
5	N.C
6	N.C
7	RQ/DT
8	RQ/DT
9	N.C
10	N.C
11	+5V
12	N.C
13	0V (GND)
14	N.C
15	F.G
Connector shell	F.G

Note: Leave test terminals (Pin No. 9 and 10) disconnected during use.

• ST748 (L), ST758 (L)

Output connector (pin type)
D-sub 15-pin
Applicable connector
HDAB-15S (Hirose Electric)

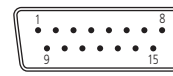

Alternately, an equivalent product (D-sub series) can be used

Pin No.	Signal
1	0V (GND)
2	0V (GND)
3	+5V
4	+5V
5	DT
6	DT
7	RQ
8	RQ
9	N.C
10	N.C
11	+5V
12	N.C
13	0V (GND)
14	N.C
15	F.G
Connector shell	F.G

Note: Leave test terminals (Pin No. 9 and 10) disconnected during use.

Mounting dimensions

• Scale base type (100 to 3000mm)

Unit: mm

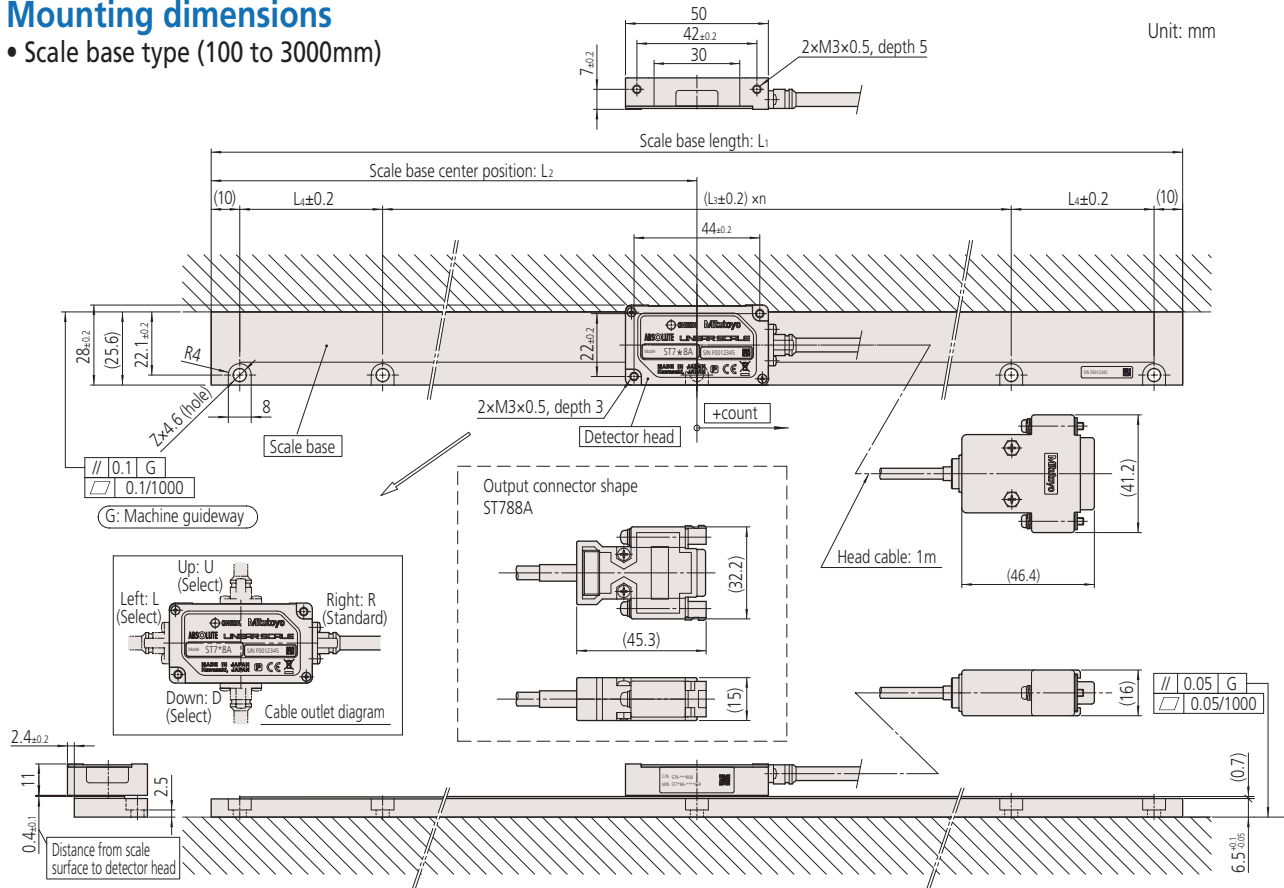

Dimensions

Order No.	Code	Effective range (mm)	Maximum travel length (mm)	L ₁ (mm)	L ₂ (mm)	L ₃ (mm)	n	L ₄ (mm)	No. of mounting holes Z
579-301*□8	ST7◇8 (A) -100A-*	100	110	180	90	80	2	—	3
579-302*□8	ST7◇8 (A) -200A-*	200	210	280	140	130			
579-303*□8	ST7◇8 (A) -300A-*	300	310	380	190	180			
579-304*□8	ST7◇8 (A) -400A-*	400	410	480	240	230			
579-305*□8	ST7◇8 (A) -500A-*	500	510	580	290	280			
579-306*□8	ST7◇8 (A) -600A-*	600	610	680	340	330	4	5	
579-307*□8	ST7◇8 (A) -700A-*	700	710	780	390	380			
579-308*□8	ST7◇8 (A) -800A-*	800	810	880	440	430			
579-309*□8	ST7◇8 (A) -900A-*	900	910	980	490	480	6	7	
579-310*□8	ST7◇8 (A) -1000A-*	1000	1010	1080	540	530			
579-311*□8	ST7◇8 (A) -1100A-*	1100	1110	1180	590	580			
579-312*□8	ST7◇8 (A) -1200A-*	1200	1210	1280	640	630	8	9	
579-313*□8	ST7◇8 (A) -1300A-*	1300	1310	1380	690	680			
579-314*□8	ST7◇8 (A) -1400A-*	1400	1410	1480	740	730			
579-315*□8	ST7◇8 (A) -1500A-*	1500	1510	1580	790	780	10	11	
579-316*□8	ST7◇8 (A) -1600A-*	1600	1610	1680	840	830			
579-317*□8	ST7◇8 (A) -1700A-*	1700	1710	1780	890	880			
579-318*□8	ST7◇8 (A) -1800A-*	1800	1810	1880	940	930	12	13	
579-319*□8	ST7◇8 (A) -1900A-*	1900	1910	1980	990	980			
579-320*□8	ST7◇8 (A) -2000A-*	2000	2010	2080	1040	1030			
579-321*□8	ST7◇8 (A) -2100A-*	2100	2110	2180	1090	1080	14	15	
579-322*□8	ST7◇8 (A) -2200A-*	2200	2210	2280	1140	1130			
579-323*□8	ST7◇8 (A) -2300A-*	2300	2310	2380	1190	1180			
579-324*□8	ST7◇8 (A) -2400A-*	2400	2410	2480	1240	1230	12	17	
579-325*□8	ST7◇8 (A) -2500A-*	2500	2510	2580	1290	1280			
579-326*□8	ST7◇8 (A) -2600A-*	2600	2610	2680	1340	1330			
579-327*□8	ST7◇8 (A) -2700A-*	2700	2710	2780	1390	1380	14	17	
579-328*□8	ST7◇8 (A) -2800A-*	2800	2810	2880	1440	1430			
579-328*□8	ST7◇8 (A) -2900A-*	2900	2910	2980	1490	1480			
579-330*□8	ST7◇8 (A) -3000A-*	3000	3010	3080	1540	1530	14	130	17

The ◇ code indicates the interface specification (0,4,5,7,8).
 The Order No. and the * code indicate the direction of the head cable (R, L, U, D).
 The □ in the Order No. is as described below.

- ST708A: 0
- ST748A: 4
- ST748: 3
- ST758: 5
- ST778A: 7
- ST788A: 8



Mounting dimensions

- Scale base type (3200 to 6000mm)

Unit: mm

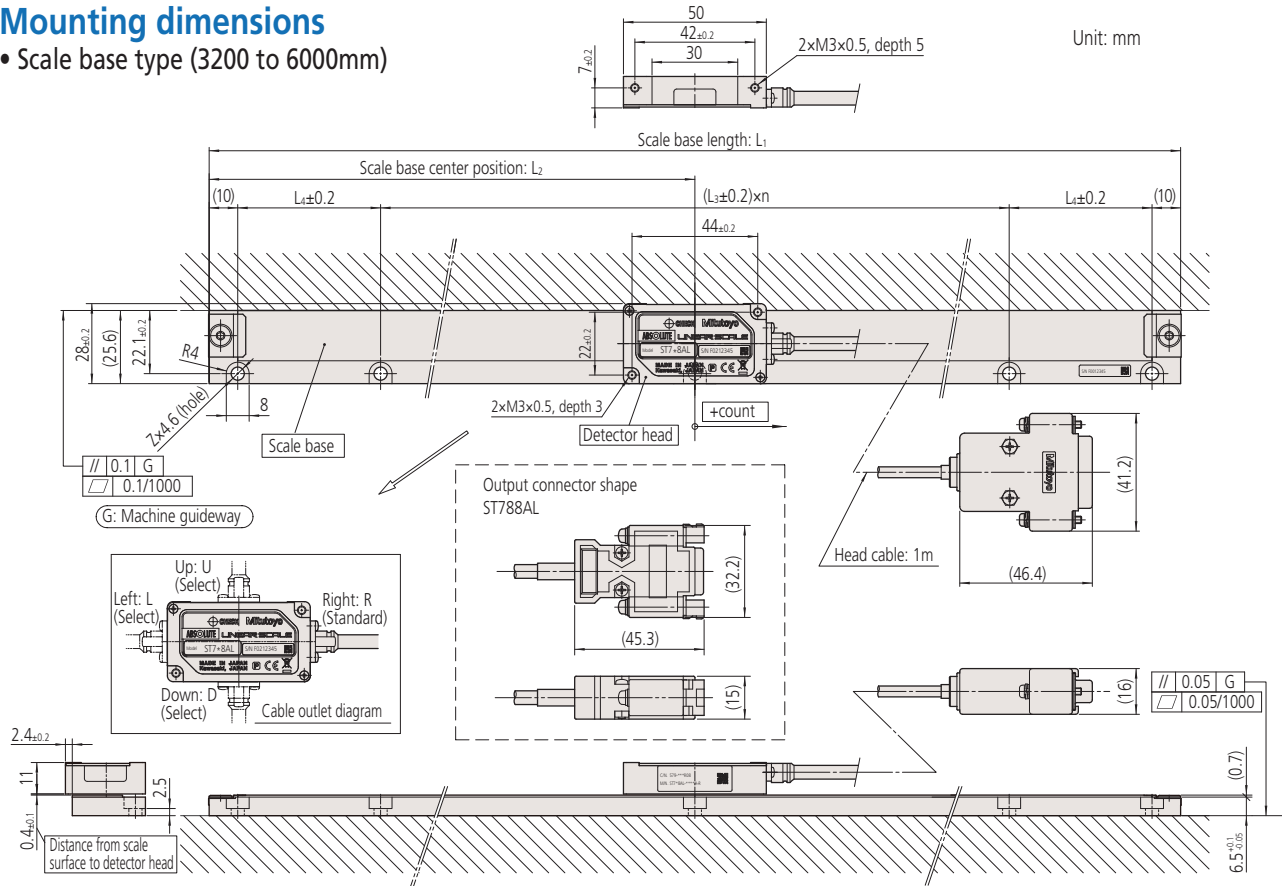

Dimensions

Order No.	Code	Effective range (mm)	Maximum travel length (mm)	L1 (mm)	L2 (mm)	L3 (mm)	n	L4 (mm)	Z
579-331* □ 8	ST7◇8 (A) L-3200A-*	3200	3210	3280	1640	200	14	230	17
579-332* □ 8	ST7◇8 (A) L-3400A-*	3400	3410	3480	1740		16	130	19
579-333* □ 8	ST7◇8 (A) L-3600A-*	3600	3610	3680	1840		16	230	19
579-334* □ 8	ST7◇8 (A) L-3800A-*	3800	3810	3880	1940		18	130	21
579-335* □ 8	ST7◇8 (A) L-4000A-*	4000	4010	4080	2040		18	230	21
579-336* □ 8	ST7◇8 (A) L-4200A-*	4200	4210	4280	2140		20	130	23
579-337* □ 8	ST7◇8 (A) L-4400A-*	4400	4410	4480	2240		20	230	23
579-338* □ 8	ST7◇8 (A) L-4600A-*	4600	4610	4680	2340		22	130	25
579-339* □ 8	ST7◇8 (A) L-4800A-*	4800	4810	4880	2440		22	230	25
579-340* □ 8	ST7◇8 (A) L-5000A-*	5000	5010	5080	2540		24	130	27
579-341* □ 8	ST7◇8 (A) L-5200A-*	5200	5210	5280	2640		24	230	27
579-342* □ 8	ST7◇8 (A) L-5400A-*	5400	5410	5480	2740		26	130	29
579-343* □ 8	ST7◇8 (A) L-5600A-*	5600	5610	5680	2840		26	230	29
579-344* □ 8	ST7◇8 (A) L-5800A-*	5800	5810	5880	2940		28	130	31
579-345* □ 8	ST7◇8 (A) L-6000A-*	6000	6010	6080	3040		28	230	31

The ◇ code indicates the interface specification (0,4,5,7,8).
 The Order No. and the * code indicate the direction of the head cable (R, L, U, D).
 The □ in the Order No. is as described below.

- ST708AL: 0
- ST748AL: 4
- ST748L: 3
- ST758L: 5
- ST778AL: 7
- ST788AL: 8

Absolute Scale Unit
ABS ST700 Series

Mounting dimensions

• Glass scale type (100 to 1100mm)

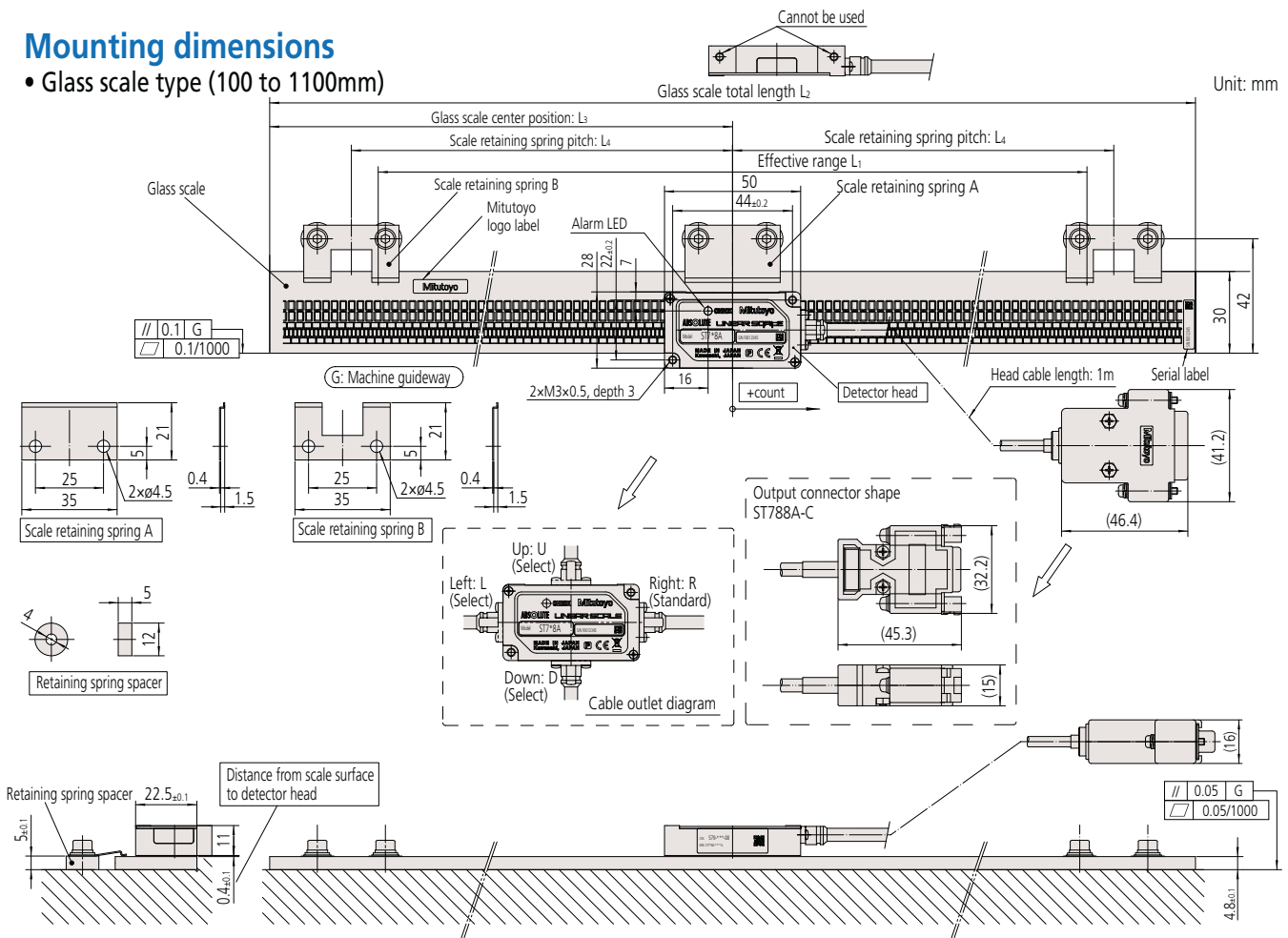

Dimensions

• Glass scale type (100 to 1100mm)

Order No.	Code	Effective range L ₁ (mm)	L ₂ (mm)	L ₃ (mm)	L ₄ (mm)	No. of scale retaining springs A	No. of scale retaining springs B	No. of retaining spring spacers
579-351* □ 8	ST7 □ 8A-100C-*	100	175	87.5	65	1	2	6
579-352* □ 8	ST7 □ 8A-200C-*	200	275	137.5	115			
579-353* □ 8	ST7 □ 8A-300C-*	300	375	187.5	160			
579-354* □ 8	ST7 □ 8A-400C-*	400	475	237.5	105			
579-355* □ 8	ST7 □ 8A-500C-*	500	575	287.5	127.5		4	10
579-356* □ 8	ST7 □ 8A-600C-*	600	675	337.5	152.5			
579-357* □ 8	ST7 □ 8A-700C-*	700	775	387.5	120			
579-358* □ 8	ST7 □ 8A-800C-*	800	875	437.5	135			
579-359* □ 8	ST7 □ 8A-900C-*	900	975	487.5	150	6	14	
579-360* □ 8	ST7 □ 8A-1000C-*	1000	1075	537.5	125			
579-361* □ 8	ST7 □ 8A-1100C-*	1100	1200	600	140	8	18	

The order No. and the * code indicate the direction of the head cable (R, L, U, D).

The order No. and the □ code specify the interface specification (0, 4, 5, 7, 8).

Note: A thin type (adhesive fixing specification) is available to special order.

Signal Adjusting Method When Mounting ABS ST700 Series

- In order to perform signal adjustment and confirmation after the unit is mounted, conditioning is necessary using a PC and application software (ABS ST700 Signal Adjustment Program). (For conditioning, allow a travel distance of at least 60mm.)

The following settings and confirmation are possible with this software:

- Scale signal automatic adjustment → It is necessary to mount the scale base and detector head detector with specified dimensions.
- Scale signal amplitude (signal strength) confirmation
- Scale origin (absolute position data of zero) setting
- Absolute position data confirmation
- Error history clear
- ABS resultant error checking (effective range 3200mm to 6000mm)

Required items

Item	Quantity	Details	Notes
PC*	1	DOS/V (Windows version)	Provided by user
Conversion unit	1	USB-485(422)DS15P (System Sacom Industry Corp.)	Option (bundle)
Connection cable A	1	USB cable	
Connection cable B	1	RS-485 cable or RS-422 cable	
Application software	1	ABS ST700 Signal Adjustment Program	

* This program requires a PC with the following operating environment.

PC: DOS/V with Pentium 200 MHz or faster (with USB port)
 Memory: 64MB min. (128MB recommended)
 Program size: 10MB
 OS: Windows95 or later
 Monitor: 256 colors, 800×600 or higher (1024×768 or higher is recommended)
 USB: COM1 is normally used (other ports can also be used)

“Conversion unit, application software” set

Set No.	Applicable model	Conversion unit	Connection cable B
06ADZ751	ST70 □ A, ST70 □ AL	USB-485 DS15P (main unit)	MIT cable
06ADT457	ST74 □ A, ST74 □ AL	USB-485 DS15P (main unit)	MEL-J4/J3 cable
06ADP485	ST77 □ A, ST77 □ AL ST78 □ A, ST78 □ AL	USB-485 DS15P (main unit)	Y/MAT cable
06ADZ752	ST74 □ , ST74 □ L	USB-422 DS15P (main unit)	MDS cable
06ADR760	ST75 □ , ST75 □ L	USB-422 DS15P (main unit)	FUNAC cable

Connection method

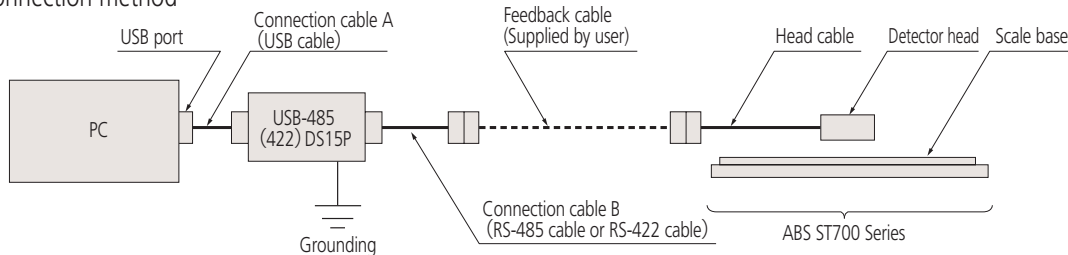

* To prevent the possibility of electric shock the device must be grounded.

* When using Part No.06ADZ751, connect the head cable and the connection cable B together.

* The conversion unit's power source is supplied via connection cable A from the PC USB port.

* In the “Applicable model” column, 1,2,3,4,8,9 apply to □. Prepare the appropriate conversion unit and connection cable B for the scale to be used.

Compatibility of Detector Head and Main Scale

- Note that for the ST700 series (compact type) with an effective range 3000 mm or less or 3200 mm or more, the main scale and the detector head are different so they are not compatible.
- The communication standards are different for the ST7 □ (L) and ST7 □ □ A (L), so they are not compatible.

Main scale		Detector head
For effective range of 3200mm to 6000mm	← Compatible →	For effective range of 3200mm to 6000mm
	← Not compatible →	
For effective range of 3000mm or less	← Compatible →	For effective range of 3000mm or less

Assembly Type ABS AT Series

Absolute Scale Unit (Slim Spar Type)

ABS AT500 Series

(Resolution 0.005 μ m)



ABS AT500-S Series

ABS AT500-H Series

Features

- This scale achieves the Absolute Linear Scale's highest level resolution of 0.005 μ m
- The ABS AT500-S Series realizes vibration resistance of 196m/s² (20G) and shock-resistance of 343m/s² (35G), suitable for use with heavy cutting equipment and for high-speed machining.
- The ABS AT500-H Series has high repeatability, excellent temperature characteristics, and enables highly accurate and stable positioning.
- Slim shape is suitable for space-saving designs.
- Compatible with servo amplifiers from a range of companies (high-speed serial interfaces).

How to read the code

ABS AT5 5 - -

Interface specification

Applicable systems	Scale code
FANUC Ltd. control devices FS-i Series POWER Mate i	ABS AT555
Mitsubishi Electric Corporation control devices MITSUBISHI CNC Series MDS-D/MDS-DH Series	ABS AT545
Mitsubishi Electric Corporation MR-J4/MR-J3 Series	ABS AT545A ABS AT505
Amplifier compatible with the Mitutoyo ENSIS interface	ABS AT505A

Note: ABS AT55

Communication method

Blank: Full-duplex communication
A: Half-duplex communication

Note: For details regarding the applicable system, please consult with the individual manufacturer.

Base position (the 'zero elongation' point)*

C: Midpoint of effective range
L: End of effective range (+ side end)
R: End of effective range (- side end)

Note: L and R are only for the high-accuracy type

* This refers to the fixed point on the scale around which clamping arrangements ensure that any expansion or contraction due to temperature change occurs.

Scale unit specifications

S: High-rigidity type
H: High-accuracy type

Scale configuration

ABS AT500-S Series

ABS AT55-SC
ABS AT55A-SC

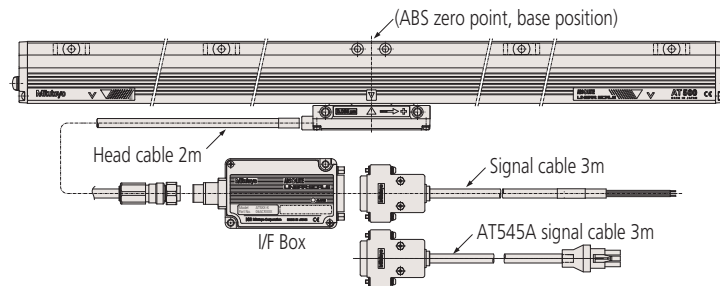

ABS AT500-H Series

ABS AT55-HC
ABS AT55A-HC

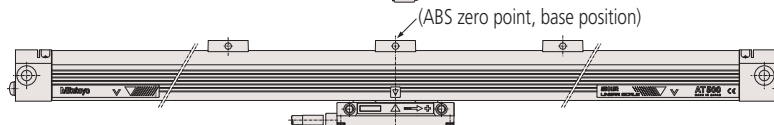

ABS AT55-HR
ABS AT55A-HR

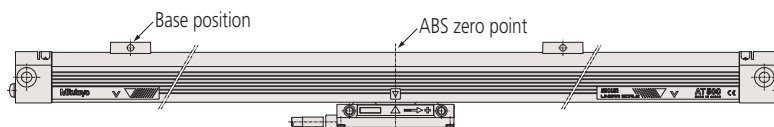

ABS AT55-HL
ABS AT55A-HL

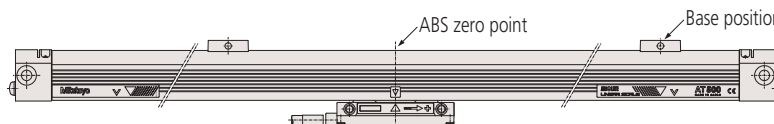

Specifications

Item	Code	High-accuracy type		
		High-rigidity type ABS AT5□5-SC	High-accuracy type ABS AT5□5-HC	ABS AT5□5-HL/HR
Detection method		Electrostatic capacitance type / photoelectric type composite ABS linear encoder		
How to mount the scale unit		Multi-point elastic fixing	3 or 5-point elastic fixing	3 or 4-point elastic fixing
Base position		Midpoint of effective range		End of effective range HL: (+ side of absolute value) HR: (- side of absolute value)
Effective range		100 to 2200mm	100 to 1000mm	100 to 350mm
Resolution		0.005μm (20μm/4096)*		
Maximum response speed		150m/min (2.5m/s)	72m/min (1.2m/s)	
Accuracy (20°C)		(3+3L ₀ /1000) μm L ₀ : Effective range (mm)	(2+2L ₀ /1000) μm L ₀ : Effective range (mm)	
Thermal expansion coefficient		(8.5±0.5) × 10 ⁻⁶ /°C		
Vibration resistance		196 m/s ² (20G) (55 to 2000Hz)	147 m/s ² (15G) (55 to 2000Hz)	
Shock resistance		343m/s ² (35G) (half-sine 11ms)	196m/s ² (20G) (half-sine 11ms)	
Power supply voltage		5VDC±5%		
Maximum current consumption		270mA (Max)		
Maximum sliding force		4N		
Operating temperature/humidity		0 to 45°C, 20 to 80%RH (no condensation)		
Storage temperature/humidity		-20 to 70°C, 20 to 80%RH (no condensation)		
Protection rating		Scale unit: Equivalent to IP53, I/F box: not waterproof		
Alarm indication		Scale alarm indicated by LED on I/F Box		
Head cable length		2m		
Signal cable length		3m		

* Because the 20μm signal is divided by 4096, the actual value is 0.0048828125μm. When setting the minimum resolution on the controller, always enter the actual value.

System configuration (See instruction manual)

Configuration example 1

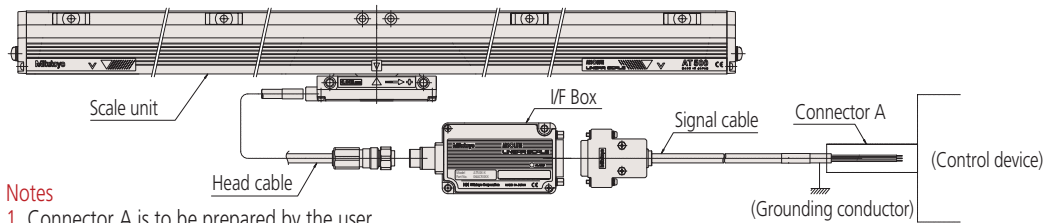

Notes

1. Connector A is to be prepared by the user.
2. Connector A and the grounding conductor are to be connected by the user.
3. In the above configuration, the maximum cable length is 10m for the head cable and 10m for the signal cable (total 20m). (Specifications other than the standard cable length are special order.)

Configuration example 2

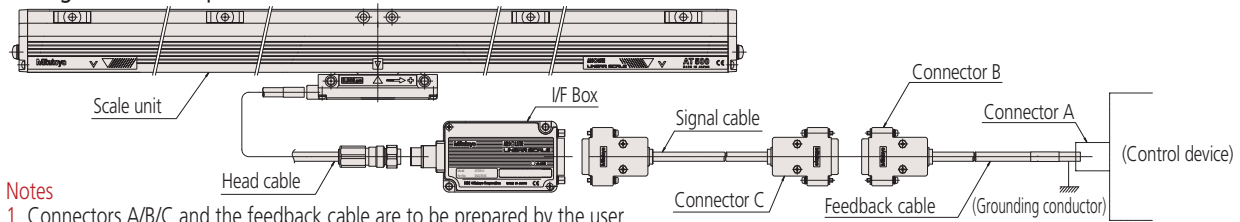

Notes

1. Connectors A/B/C and the feedback cable are to be prepared by the user.
2. Connectors A/B/C and the grounding conductor are to be connected by the user.
3. When fabricating a feedback cable, ensure that the total cable length is 29m or less. However, the maximum head cable length is 10m and the maximum signal cable length is 5m.

ABS AT545A

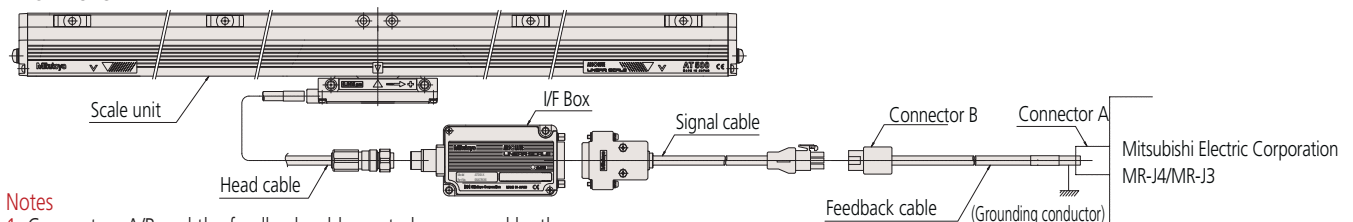

Notes

1. Connectors A/B and the feedback cable are to be prepared by the user.
2. Connectors A/B and the grounding conductor are to be connected by the user.
3. A Mitsubishi Electric Corporation encoder cable can be used as the feedback cable. Model: MR-JCCBL□M-H □ is the cable length (2 or 5m)
 - * When using the encoder cable, ensure that the total cable length is 10m or less.
 - * The feedback cable configuration depends on the system. Please contact Mitsubishi Electric Corporation for details.

Output specification

• ABS AT555/AT545/AT505 (flying leads)

Wire color	Signal
Brown/Red	+5V
White/Black	GND
Orange	\overline{DT}
Yellow	DT
Green	REQ
Blue	REQ
Purple	Phase A
Gray	Phase B
Shield	FG

Notes

- 1: Phase A and Phase B are used as test signals. Keep them disconnected during use.
- 2: Connect the shield wire to the grounding conductor.

• ABS AT545A

Output connector (pin type): Tyco Electronics Japan
Mini-Universal Mate-N-Lock Connector 9P
172169-9 (Housing: Black)

Applicable connector: 172161-9 (Housing: Black)

Pin No.	Signal
1	MR (REQ/DT)
2	MRR (REQ/DT)
4	(DT)
5	(DT)
7	PS (+5V)
8	OV (GND)
9	F.G
3.6	N.C

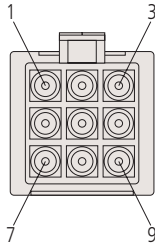

• ABS AT505A (flying leads)

Wire color	Signal
Brown/Red	+5V
White/Black	GND
Orange	N.C
Yellow	N.C
Green	$\overline{REQ/DT}$
Blue	REQ/DT
Purple	Phase A
Gray	Phase B
Shield	FG

Notes

- 1: Phase A and Phase B are used as test signals. Keep them disconnected during use.
- 2: Connect the shield wire to the grounding conductor.

Cable dimensions

Unit: mm

• ABS AT555/505

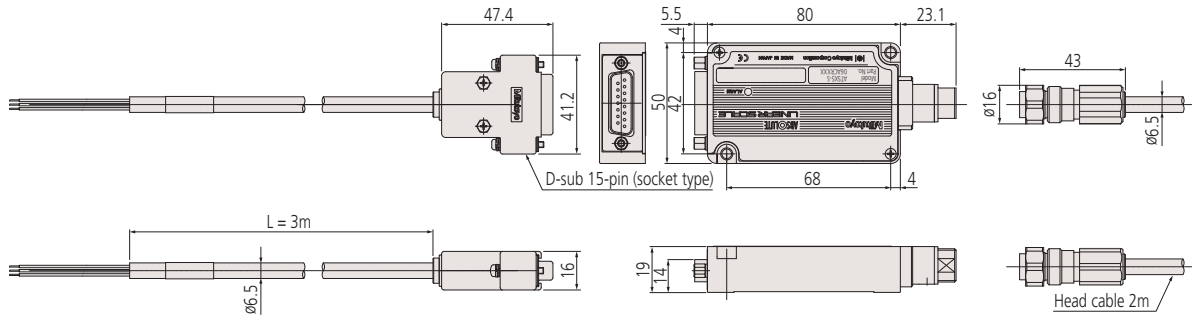

• ABS AT545A

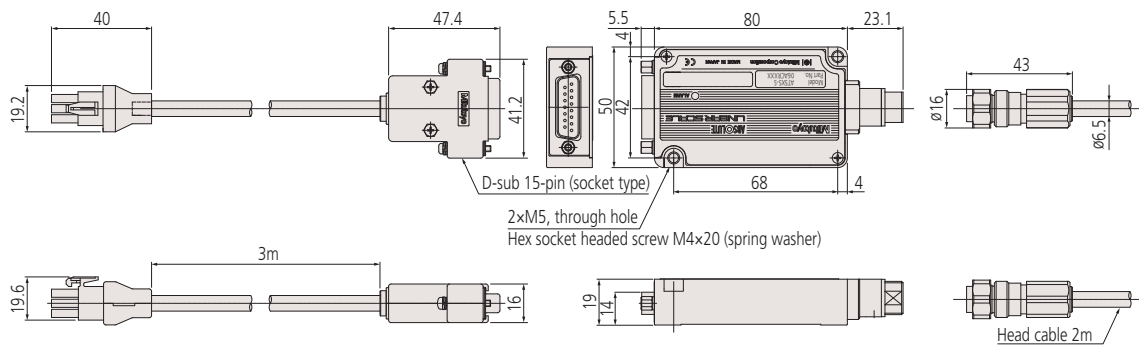

Absolute Scale Unit
ABS AT500 Series

Mounting dimensions (SC Type)

Unit: mm

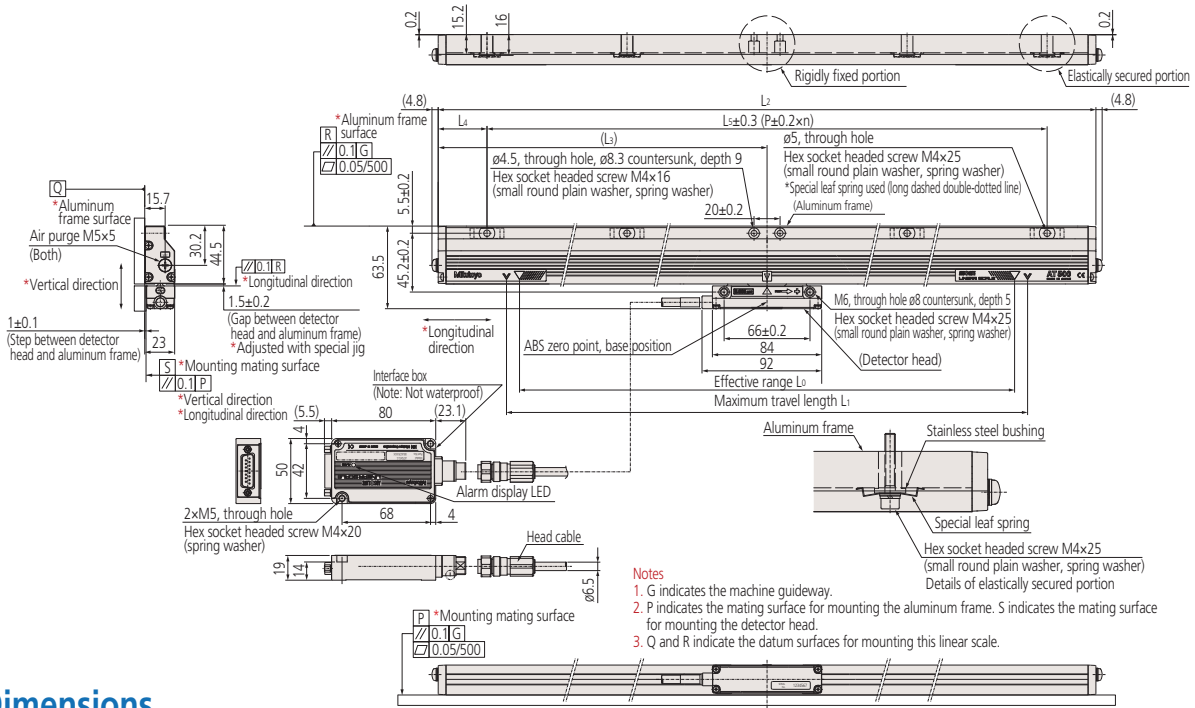

- Notes
1. G indicates the machine guideway.
 2. P indicates the mating surface for mounting the aluminum frame. S indicates the mating surface for mounting the detector head.
 3. Q and R indicate the datum surfaces for mounting this linear scale.

Dimensions

Effective range L ₀ (mm)	Maximum travel length L ₁ (mm)	Overall length L ₂ (mm)	Distance to center L ₃ (mm)	Mounting pitch			No. of mounting holes n
				L ₄ (mm)	L ₅ (mm)	P (mm)	
100	120	225	112.5	37.5	150	75	2
200	220	325	162.5	37.5	250	125	2
300	320	425	212.5	37.5	350	175	2
400	420	525	262.5	62.5	400	200	2
500	520	625	312.5	62.5	500	125	4
600	620	725	362.5	62.5	600	150	4
700	720	825	412.5	62.5	700	175	4
800	820	925	462.5	62.5	800	200	4
900	920	1025	512.5	62.5	900	150	6
1000	1020	1125	562.5	37.5	1050	175	6
1100	1120	1225	612.5	87.5	1050	175	6
1200	1220	1325	662.5	62.5	1200	200	6
1300	1320	1425	712.5	112.5	1200	150	8
1400	1420	1525	762.5	62.5	1400	175	8
1500	1520	1625	812.5	112.5	1400	175	8
1600	1620	1725	862.5	62.5	1600	200	8
1800	1820	1925	962.5	87.5	1750	175	10
2000	2020	2125	1062.5	62.5	2000	200	10
2200	2220	2325	1162.5	112.5	2100	175	12

Codes and Order Numbers

• ABS AT555-SC

Order No.	Code
539-761-50	AT555- 100-SC
539-763-50	AT555- 200-SC
539-765-50	AT555- 300-SC
539-767-50	AT555- 400-SC
539-769-50	AT555- 500-SC
539-771-50	AT555- 600-SC
539-773-50	AT555- 700-SC
539-775-50	AT555- 800-SC
539-776-50	AT555- 900-SC
539-777-50	AT555-1000-SC
539-778-50	AT555-1100-SC
539-779-50	AT555-1200-SC
539-780-50	AT555-1300-SC
539-781-50	AT555-1400-SC
539-782-50	AT555-1500-SC
539-783-50	AT555-1600-SC
539-785-50	AT555-1800-SC
539-786-50	AT555-2000-SC
539-787-50	AT555-2200-SC

• ABS AT545/AT545A-SC

Order No.	Code
539-731-□□	AT545(A)- 100-SC
539-733-□□	AT545(A)- 200-SC
539-735-□□	AT545(A)- 300-SC
539-737-□□	AT545(A)- 400-SC
539-739-□□	AT545(A)- 500-SC
539-741-□□	AT545(A)- 600-SC
539-743-□□	AT545(A)- 700-SC
539-745-□□	AT545(A)- 800-SC
539-746-□□	AT545(A)- 900-SC
539-747-□□	AT545(A)-1000-SC
539-748-□□	AT545(A)-1100-SC
539-749-□□	AT545(A)-1200-SC
539-750-□□	AT545(A)-1300-SC
539-751-□□	AT545(A)-1400-SC
539-752-□□	AT545(A)-1500-SC
539-753-□□	AT545(A)-1600-SC
539-755-□□	AT545(A)-1800-SC
539-756-□□	AT545(A)-2000-SC
539-757-□□	AT545(A)-2200-SC

• ABS AT505/AT505A-SC

Order No.	Code
539-161-□□	AT505(A)- 100-SC
539-163-□□	AT505(A)- 200-SC
539-165-□□	AT505(A)- 300-SC
539-167-□□	AT505(A)- 400-SC
539-169-□□	AT505(A)- 500-SC
539-171-□□	AT505(A)- 600-SC
539-173-□□	AT505(A)- 700-SC
539-175-□□	AT505(A)- 800-SC
539-176-□□	AT505(A)- 900-SC
539-177-□□	AT505(A)-1000-SC
539-178-□□	AT505(A)-1100-SC
539-179-□□	AT505(A)-1200-SC
539-180-□□	AT505(A)-1300-SC
539-181-□□	AT505(A)-1400-SC
539-182-□□	AT505(A)-1500-SC
539-183-□□	AT505(A)-1600-SC
539-185-□□	AT505(A)-1800-SC
539-186-□□	AT505(A)-2000-SC
539-187-□□	AT505(A)-2200-SC

* The □□ in the Order No. is as follows. AT545 : 50
AT545A: 51

* The □□ in the Order No. is as follows. AT505 : 50
AT505A: 51



Absolute Scale Unit
ABS AT500 Series

Mounting dimensions (HC Type)

Unit: mm

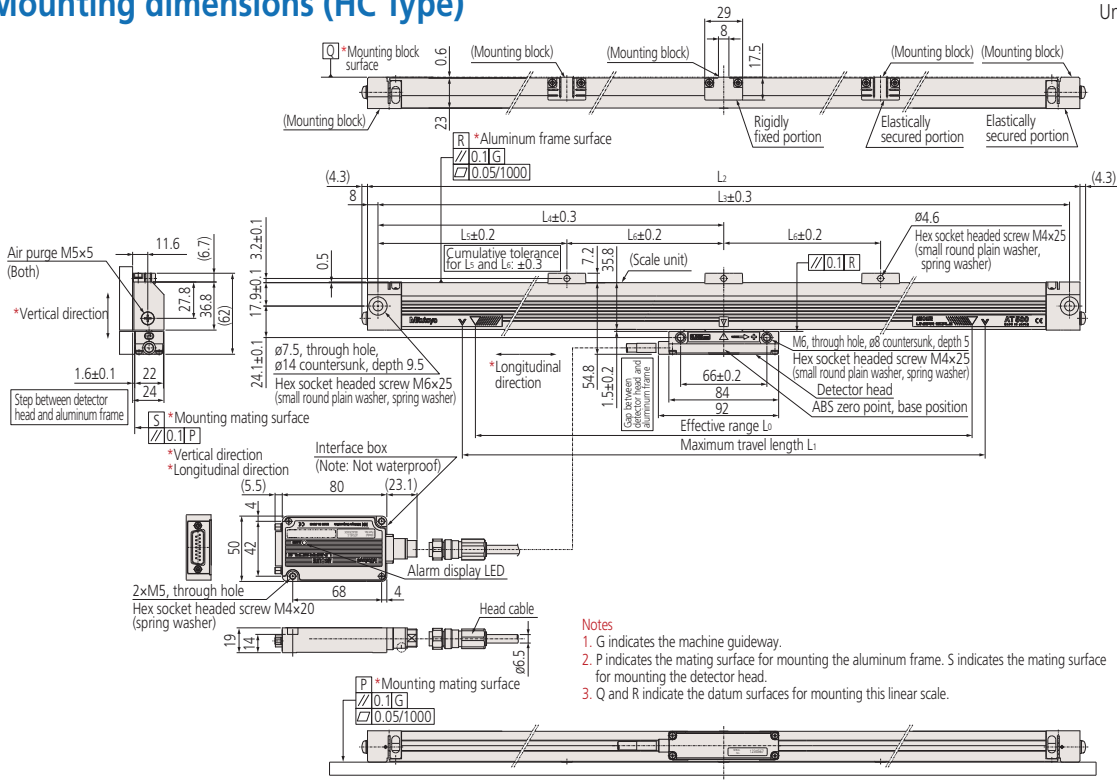

Notes

1. G indicates the machine guideway.
2. P indicates the mating surface for mounting the aluminum frame. S indicates the mating surface for mounting the detector head.
3. Q and R indicate the datum surfaces for mounting this linear scale.

Dimensions

Effective range L ₀ (mm)	Maximum travel length L ₁ (mm)	Overall length L ₂ (mm)	Mounting pitch			
			L ₃ (mm)	L ₄ (mm)	L ₅ (mm)	L ₆ (mm)
100	120	265	249	124.5	—	—
150	170	315	299	149.5	—	—
200	220	365	349	174.5	—	—
250	270	415	399	199.5	—	—
300	320	465	449	224.5	—	—
350	370	515	499	249.5	—	—
400	420	565	549	274.5	—	—
450	470	615	599	299.5	—	—
500	520	665	649	324.5	—	—
600	620	765	749	(374.5)	204.5	170
700	720	865	849	(424.5)	224.5	200
750	770	915	899	(449.5)	224.5	225
800	820	965	949	(474.5)	244.5	230
900	920	1065	1049	(524.5)	264.5	260
1000	1020	1165	1149	(574.5)	284.5	290

Codes and Order Numbers

• ABS AT555-HC

Order No.	Code
539-761-60	AT555- 100-HC
539-762-60	AT555- 150-HC
539-763-60	AT555- 200-HC
539-764-60	AT555- 250-HC
539-765-60	AT555- 300-HC
539-766-60	AT555- 350-HC
539-767-60	AT555- 400-HC
539-768-60	AT555- 450-HC
539-769-60	AT555- 500-HC
539-771-60	AT555- 600-HC
539-773-60	AT555- 700-HC
539-774-60	AT555- 750-HC
539-775-60	AT555- 800-HC
539-776-60	AT555- 900-HC
539-777-60	AT555-1000-HC

• ABS AT545/AT545A-HC

Order No.	Code
539-731-□□	AT545(A)- 100-HC
539-732-□□	AT545(A)- 150-HC
539-733-□□	AT545(A)- 200-HC
539-734-□□	AT545(A)- 250-HC
539-735-□□	AT545(A)- 300-HC
539-736-□□	AT545(A)- 350-HC
539-737-□□	AT545(A)- 400-HC
539-738-□□	AT545(A)- 450-HC
539-739-□□	AT545(A)- 500-HC
539-741-□□	AT545(A)- 600-HC
539-743-□□	AT545(A)- 700-HC
539-744-□□	AT545(A)- 750-HC
539-745-□□	AT545(A)- 800-HC
539-746-□□	AT545(A)- 900-HC
539-747-□□	AT545(A)-1000-HC

* The □□ in the Order No. is as follows. AT545 : 60
AT545A: 61

• ABS AT505/AT505A-HC

Order No.	Code
539-161-□□	AT505(A)- 100-HC
539-162-□□	AT505(A)- 150-HC
539-163-□□	AT505(A)- 200-HC
539-164-□□	AT505(A)- 250-HC
539-165-□□	AT505(A)- 300-HC
539-166-□□	AT505(A)- 350-HC
539-167-□□	AT505(A)- 400-HC
539-168-□□	AT505(A)- 450-HC
539-169-□□	AT505(A)- 500-HC
539-171-□□	AT505(A)- 600-HC
539-173-□□	AT505(A)- 700-HC
539-174-□□	AT505(A)- 750-HC
539-175-□□	AT505(A)- 800-HC
539-176-□□	AT505(A)- 900-HC
539-177-□□	AT505(A)-1000-HC

* The □□ in the Order No. is as follows. AT545 : 60
AT545A: 61

Absolute Scale Unit
ABS AT500 Series

Mounting dimensions (HR Type)

Unit: mm

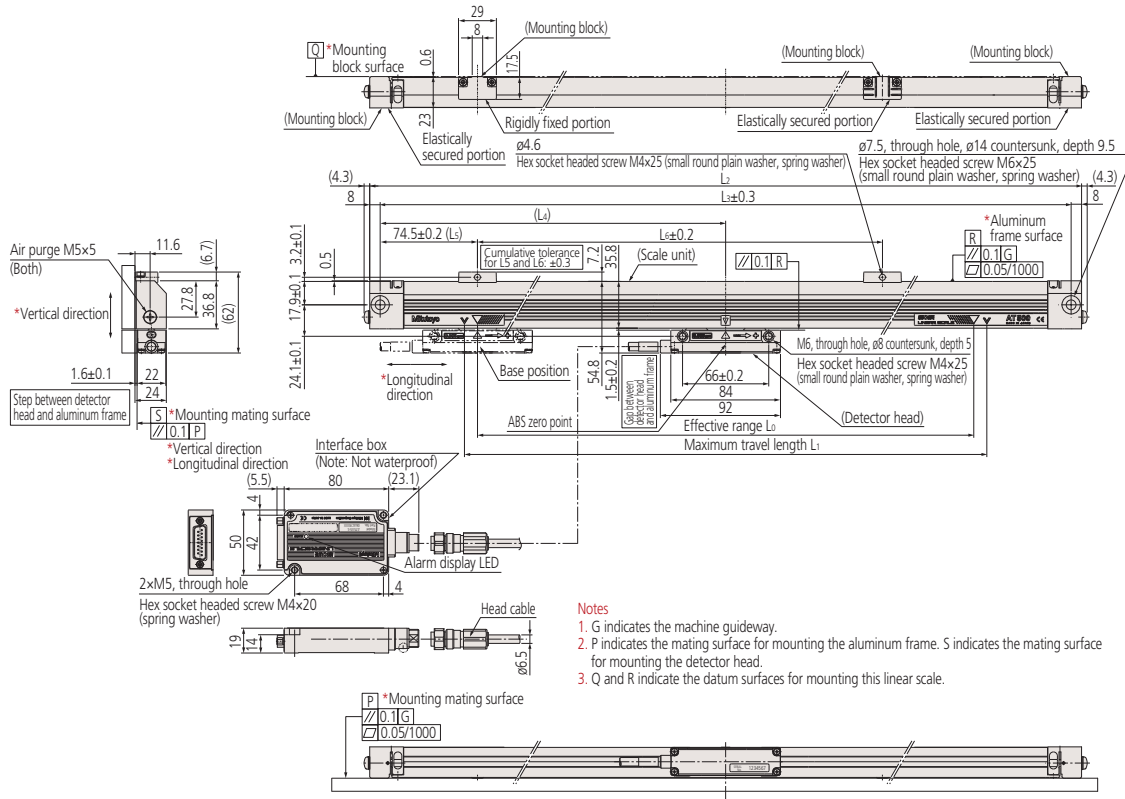

- Notes**
1. G indicates the machine guideway.
 2. P indicates the mating surface for mounting the aluminum frame. S indicates the mating surface for mounting the detector head.
 3. Q and R indicate the datum surfaces for mounting this linear scale.

Dimensions

Effective range L ₀ (mm)	Maximum travel length L ₁ (mm)	Overall length L ₂ (mm)	Mounting pitch		
			L ₃ (mm)	L ₄ (mm)	L ₆ (mm)
100	120	265	249	124.5	—
150	170	315	299	149.5	100
200	220	365	349	174.5	130
250	270	415	399	199.5	160
300	320	465	449	224.5	190
350	370	515	499	249.5	220

Codes and Order Numbers

• ABS AT555-HR

Order No.	Code
539-761-70	AT555-100-HR
539-762-70	AT555-150-HR
539-763-70	AT555-200-HR
539-764-70	AT555-250-HR
539-765-70	AT555-300-HR
539-766-70	AT555-350-HR

• ABS AT545/AT545A-HR

Order No.	Code
539-731-□□	AT545(A)-100-HR
539-732-□□	AT545(A)-150-HR
539-733-□□	AT545(A)-200-HR
539-734-□□	AT545(A)-250-HR
539-735-□□	AT545(A)-300-HR
539-736-□□	AT545(A)-350-HR

* The □□ in the Order No. is as follows. AT545 : 70
AT545A: 71

• ABS AT505/AT505A-HR

Order No.	Code
539-161-□□	AT505(A)-100-HR
539-162-□□	AT505(A)-150-HR
539-163-□□	AT505(A)-200-HR
539-164-□□	AT505(A)-250-HR
539-165-□□	AT505(A)-300-HR
539-166-□□	AT505(A)-350-HR

* The □□ in the Order No. is as follows. AT505 : 70
AT505A: 71

Absolute Scale Unit
ABS AT500 Series

Assembly Type ABS AT Series

Absolute Scale Unit (Slim Spar Type)

ABS AT500 Series

(Resolution 0.05μm)



ABSOLUTE™

Features

- High-performance Absolute Linear Scale with a resolution of 0.05μm and maximum response speed of 150 m/min.
- The ABS AT500-S Series realizes vibration resistance of 196m/s² (20G) and shock-resistance of 343m/s² (35G), suitable for use with heavy cutting equipment and for high-speed machining.
- The ABS AT500-H Series has high repeatability, excellent temperature characteristics, and enables highly accurate and stable positioning.
- Slim shape is suitable for space-saving designs.
- Compatible with servo amplifiers from a range of companies (high-speed serial interfaces).

How to read the code

ABS AT5 3 - -

Interface specification	Effective range
Applicable systems	Scale code
FANUC Ltd. control devices FS-i Series POWER Mate i	ABS AT553
Mitsubishi Electric Corporation control devices MITSUBISHI CNC Series MDS-D/MDS-DH Series	ABS AT543
Mitsubishi Electric Corporation MR-J4/MR-J3 Series	ABS AT543A
Panasonic Corporation, Motor business unit MINAS-A5, A5L, A5N, A5NL Series MINAS-A4, A4P, A4N, A4NL Series	ABS AT573A
Amplifier compatible with the Mitutoyo ENSIS interface Nikki Denso Co., Ltd. VCII/VC/VPS Series*1 Servoland Corporation SVF Series*1 PMAC JAPAN Co., Ltd. UMAC-Turbo PMAC2 Other machine types	ABS AT503A ABS AT503

Base position (the 'zero elongation' point)*
C: Midpoint of effective range
L: End of effective range (+ side end)
R: End of effective range (- side end)
 Note: L and R are only for the high-accuracy type
 * This refers to the base point of fixed point on the scale around which clamping arrangements ensure that any expansion or contraction due to temperature change occurs.

Scale unit specifications
S: High-rigidity type
H: High-accuracy type

*1 For connection to ABS AT503A

Note: ABS AT53

Communication method
Blank: Full-duplex communication
A: Half-duplex communication

Note: For details regarding the applicable system, please consult with the individual manufacturer.

Scale configuration

ABS AT500-S Series

ABS AT53-SC
 ABS AT53A-SC

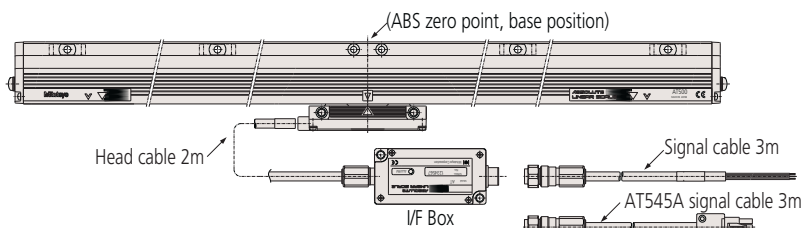

ABS AT500-H Series

ABS AT53-HC
 ABS AT53A-HC

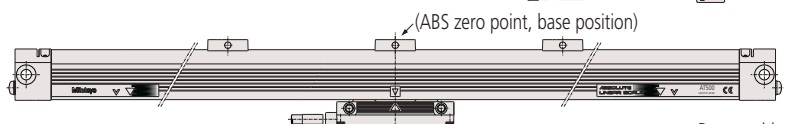

ABS AT53-HL
 ABS AT53A-HL

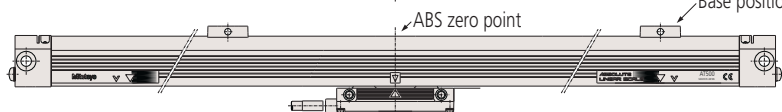

ABS AT53-HR
 ABS AT53A-HR

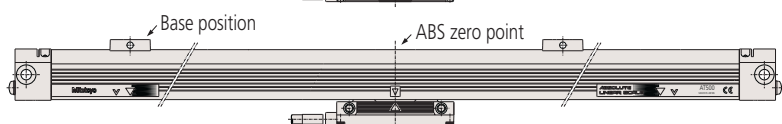

Absolute Scale Unit
ABS AT500 Series

Specifications

Item	Code	High-rigidity type	High-accuracy type	
		ABS AT5□3-SC	ABS AT5□3-HC	ABS AT5□3-HL/HR
Detection method		Electrostatic capacitance type / photoelectric type composite ABS linear encoder		
How to mount the scale unit		Multi-point elastic fixing	3 or 5-point elastic fixing	3 or 4-point elastic fixing
Base position		Midpoint of effective range		End of effective range HL: (+ side of absolute value) HR: (- side of absolute value)
Effective range		100 to 2200mm	100 to 1000mm	100 to 350mm
Resolution		0.05μm		
Maximum response speed		150m/min (2.5m/s)		
Accuracy (20°C)		(3+3L _o /1000) μm Lo: Effective range (mm)	(2+2L _o /1000) μm Lo: Effective range (mm)	
Thermal expansion coefficient		(8.5±0.5) × 10 ⁻⁶ /°C		
Vibration resistance		196 m/s ² (20G) (55 to 2000Hz)	147 m/s ² (15G) (55 to 2000Hz)	
Shock resistance		343m/s ² (35G) (half-sine 11ms)	196m/s ² (20G) (half-sine 11ms)	
Power supply voltage		5VDC±5%		
Maximum current consumption		270mA (Max)		
Maximum sliding force		4N		
Operating temperature/humidity		0 to 45°C, 20 to 80%RH (no condensation)		
Storage temperature/humidity		-20 to 70°C, 20 to 80%RH (no condensation)		
Protection rating		Scale unit: Equivalent to IP53, I/F box: not waterproof		
Alarm indication		Scale alarm indicated by LED on I/F Box		
Head cable length		2m		
Signal cable length		3m		

System configuration (See instruction manual)

Configuration example 1

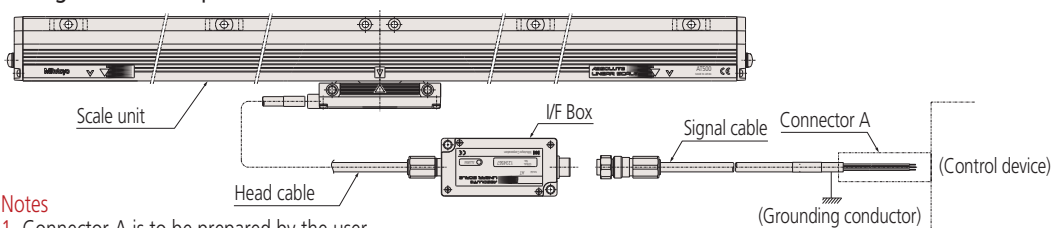

Notes

1. Connector A is to be prepared by the user.
2. Connector A and the grounding conductor are to be connected by the user.
3. In the above configuration, the maximum cable length is 10m for the head cable and 10m for the signal cable (total 20m). (Specifications other than the standard cable length are special order.)

Configuration example 2

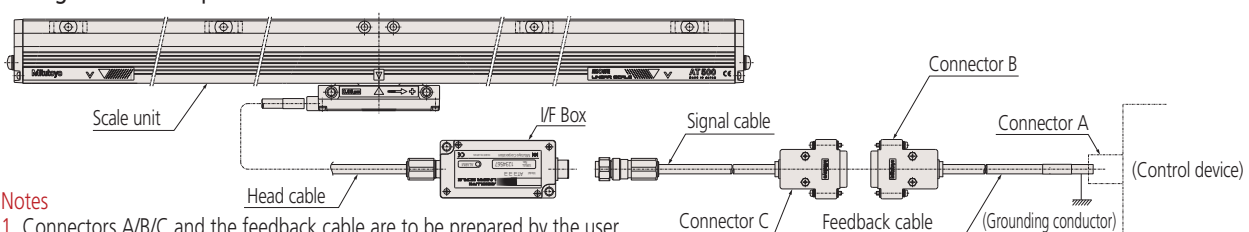

Notes

1. Connectors A/B/C and the feedback cable are to be prepared by the user.
2. Connectors A/B/C and the grounding conductor are to be connected by the user.
3. When fabricating a feedback cable, ensure that the total cable length is 29m or less. However, the maximum head cable length is 10m and the maximum signal cable length is 5m.

[ABS AT543A]

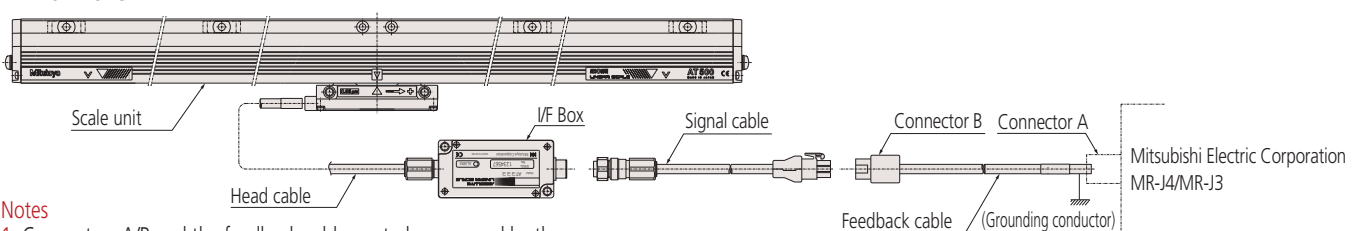

Notes

1. Connectors A/B and the feedback cable are to be prepared by the user.
2. Connectors A/B and the grounding conductor are to be connected by the user.
3. A Mitsubishi Electric Corporation encoder cable can be used as the feedback cable. Model: MR-JCCBL□M-H □ is the cable length (2 or 5m)
 - * When using the encoder cable, ensure that the total cable length is 10m or less.
 - * The feedback cable configuration depends on the system. Please contact Mitsubishi Electric Corporation for details.

Output specification

• ABS AT553/AT543/AT503 (flying leads)

Wire color	Signal
Brown/Red	+5V
White/Black	GND
Orange	DT
Yellow	DT
Green	REQ
Blue	REQ
Purple	Phase A
Gray	Phase B
Shield	FG

Notes

- 1: Phase A and Phase B are used as test signals. Keep them disconnected during use.
- 2: Connect the shield wire to the grounding conductor.

• ABS AT545A

Output connector (pin type): Tyco Electronics Japan
Mini-Universal Mate-N-Lock Connector 9P
172169-9 (Housing: Black)
Applicable connector: 172161-9 (Housing: Black)

Pin No.	Signal
1	MR (REQ/DT)
2	MRR (REQ/DT)
4	(DT)
5	(DT)
7	PS (+5V)
8	LG (GND)
9	F.G
3.6	N.C

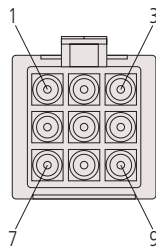

• ABS AT573A/AT503A (flying leads)

Wire color	Signal
Brown/Red	+5V
White/Black	GND
Orange	N.C
Yellow	N.C
Green	REQ/DT
Blue	REQ/DT
Purple	Phase A
Gray	Phase B
Shield	FG

Notes

- 1: Phase A and Phase B are used as test signals. Keep them disconnected during use.
- 2: Connect the shield wire to the grounding conductor.

Cable dimensions

• ABS AT553/AT543/AT573A/AT503 (A)

Unit: mm

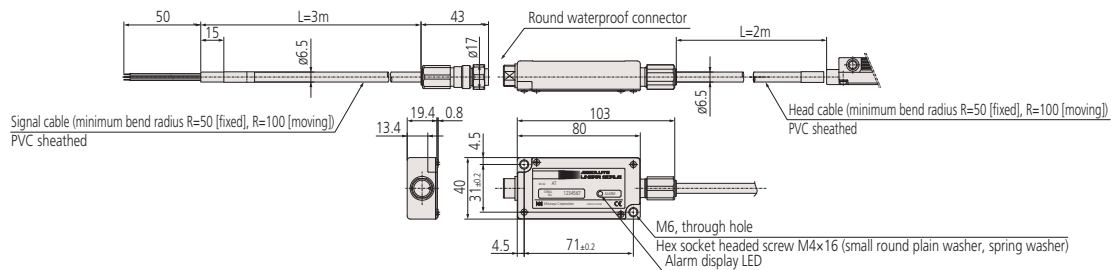

• ABS AT543A

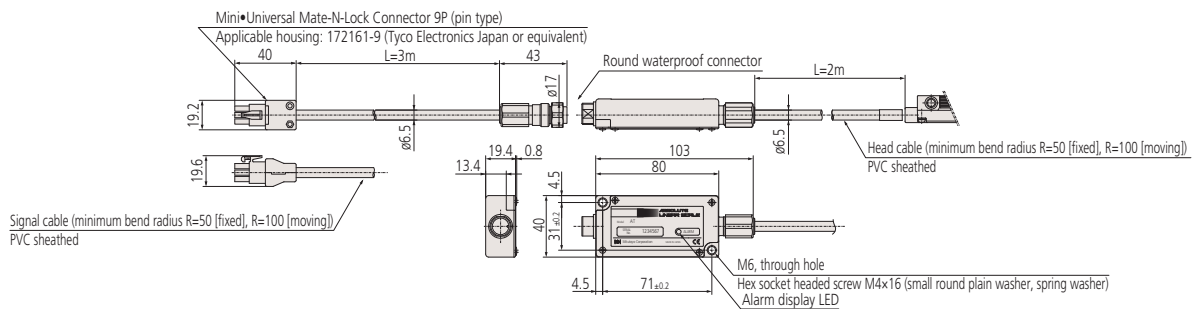

Mounting dimensions (SC Type)

Unit: mm

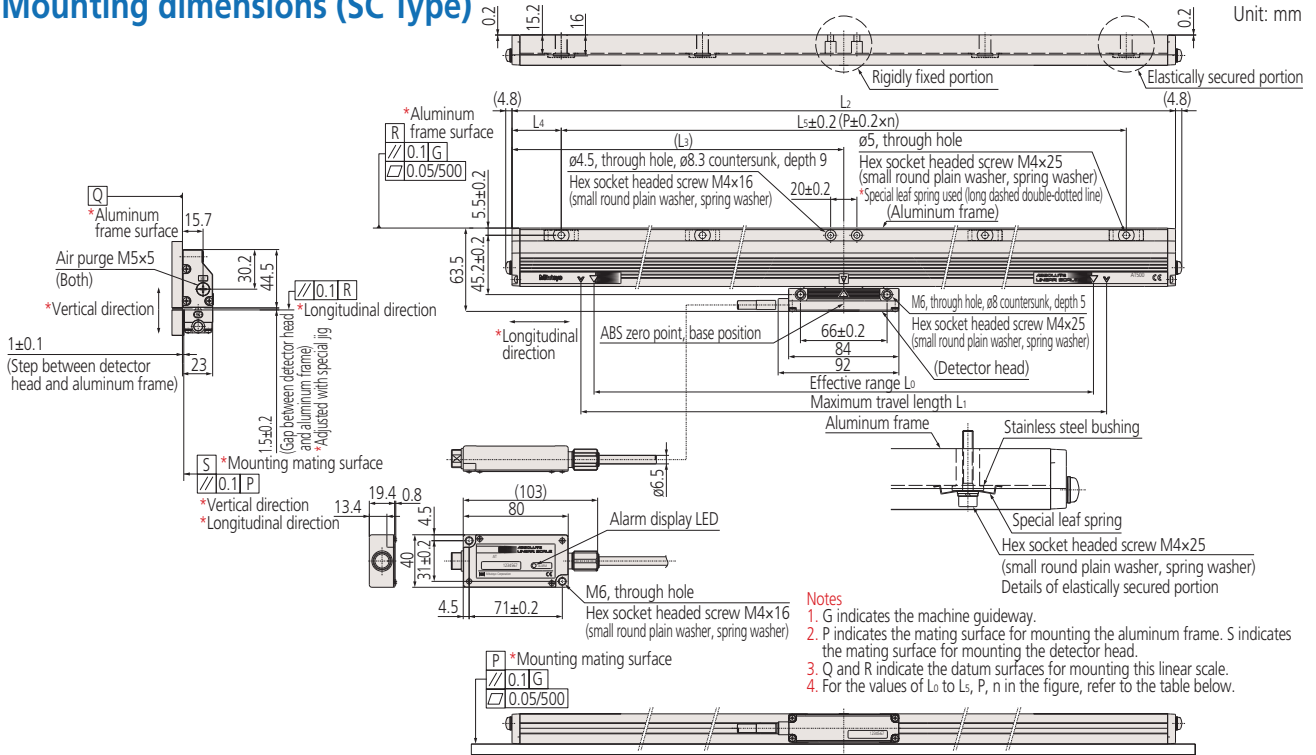

- Notes**
1. G indicates the machine guideway.
 2. P indicates the mating surface for mounting the aluminum frame. S indicates the mating surface for mounting the detector head.
 3. Q and R indicate the datum surfaces for mounting this linear scale.
 4. For the values of L_0 to L_5 , P, n in the figure, refer to the table below.

Dimensions

Effective range L_0 (mm)	Maximum travel length L_1 (mm)	Overall length L_2 (mm)	Distance to center L_3 (mm)	Mounting pitch			No. of mounting holes n
				L_4 (mm)	L_5 (mm)	P (mm)	
100	120	225	112.5	37.5	150	75	2
200	220	325	162.5	37.5	250	125	2
300	320	425	212.5	37.5	350	175	2
400	420	525	262.5	62.5	400	200	2
500	520	625	312.5	62.5	500	125	4
600	620	725	362.5	62.5	600	150	4
700	720	825	412.5	62.5	700	175	4
800	820	925	462.5	62.5	800	200	4
900	920	1025	512.5	62.5	900	150	6
1000	1020	1125	562.5	37.5	1050	175	6
1100	1120	1225	612.5	87.5	1050	175	6
1200	1220	1325	662.5	62.5	1200	200	6
1300	1320	1425	712.5	112.5	1200	150	8
1400	1420	1525	762.5	62.5	1400	175	8
1500	1520	1625	812.5	112.5	1400	175	8
1600	1620	1725	862.5	62.5	1600	200	8
1800	1820	1925	962.5	87.5	1750	175	10
2000	2020	2125	1062.5	62.5	2000	200	10
2200	2220	2325	1162.5	112.5	2100	175	12

Codes and Order Numbers

• ABS AT553-SC

Order No.	Code
539-761-10	AT553- 100-SC
539-763-10	AT553- 200-SC
539-765-10	AT553- 300-SC
539-767-10	AT553- 400-SC
539-769-10	AT553- 500-SC
539-771-10	AT553- 600-SC
539-773-10	AT553- 700-SC
539-775-10	AT553- 800-SC
539-776-10	AT553- 900-SC
539-777-10	AT553-1000-SC
539-778-10	AT553-1100-SC
539-779-10	AT553-1200-SC
539-780-10	AT553-1300-SC
539-781-10	AT553-1400-SC
539-782-10	AT553-1500-SC
539-783-10	AT553-1600-SC
539-785-10	AT553-1800-SC
539-786-10	AT553-2000-SC
539-787-10	AT553-2200-SC

• ABS AT543/AT543A-SC

Order No.	Code
539-731-□□	AT543(A)- 100-SC
539-733-□□	AT543(A)- 200-SC
539-735-□□	AT543(A)- 300-SC
539-737-□□	AT543(A)- 400-SC
539-739-□□	AT543(A)- 500-SC
539-741-□□	AT543(A)- 600-SC
539-743-□□	AT543(A)- 700-SC
539-745-□□	AT543(A)- 800-SC
539-746-□□	AT543(A)- 900-SC
539-747-□□	AT543(A)-1000-SC
539-748-□□	AT543(A)-1100-SC
539-749-□□	AT543(A)-1200-SC
539-750-□□	AT543(A)-1300-SC
539-751-□□	AT543(A)-1400-SC
539-752-□□	AT543(A)-1500-SC
539-753-□□	AT543(A)-1600-SC
539-755-□□	AT543(A)-1800-SC
539-756-□□	AT543(A)-2000-SC
539-757-□□	AT543(A)-2200-SC

• ABS AT573A-SC

Order No.	Code
539-871-11	AT573A- 100-SC
539-873-11	AT573A- 200-SC
539-875-11	AT573A- 300-SC
539-877-11	AT573A- 400-SC
539-879-11	AT573A- 500-SC
539-881-11	AT573A- 600-SC
539-883-11	AT573A- 700-SC
539-885-11	AT573A- 800-SC
539-886-11	AT573A- 900-SC
539-887-11	AT573A-1000-SC
539-888-11	AT573A-1100-SC
539-889-11	AT573A-1200-SC
539-890-11	AT573A-1300-SC
539-891-11	AT573A-1400-SC
539-892-11	AT573A-1500-SC
539-893-11	AT573A-1600-SC
539-895-11	AT573A-1800-SC
539-896-11	AT573A-2000-SC
539-897-11	AT573A-2200-SC

• ABS AT503/AT503A-SC

Order No.	Code
539-161-□□	AT503(A)- 100-SC
539-163-□□	AT503(A)- 200-SC
539-165-□□	AT503(A)- 300-SC
539-167-□□	AT503(A)- 400-SC
539-169-□□	AT503(A)- 500-SC
539-171-□□	AT503(A)- 600-SC
539-173-□□	AT503(A)- 700-SC
539-175-□□	AT503(A)- 800-SC
539-176-□□	AT503(A)- 900-SC
539-177-□□	AT503(A)-1000-SC
539-178-□□	AT503(A)-1100-SC
539-179-□□	AT503(A)-1200-SC
539-180-□□	AT503(A)-1300-SC
539-181-□□	AT503(A)-1400-SC
539-182-□□	AT503(A)-1500-SC
539-183-□□	AT503(A)-1600-SC
539-185-□□	AT503(A)-1800-SC
539-186-□□	AT503(A)-2000-SC
539-187-□□	AT503(A)-2200-SC

* The □□ in the Order No. is as follows. AT543 : 10
AT543A: 11

* The □□ in the Order No. is as follows. AT503 : 10
AT503A: 11

Mounting dimensions (HC Type)

Unit: mm

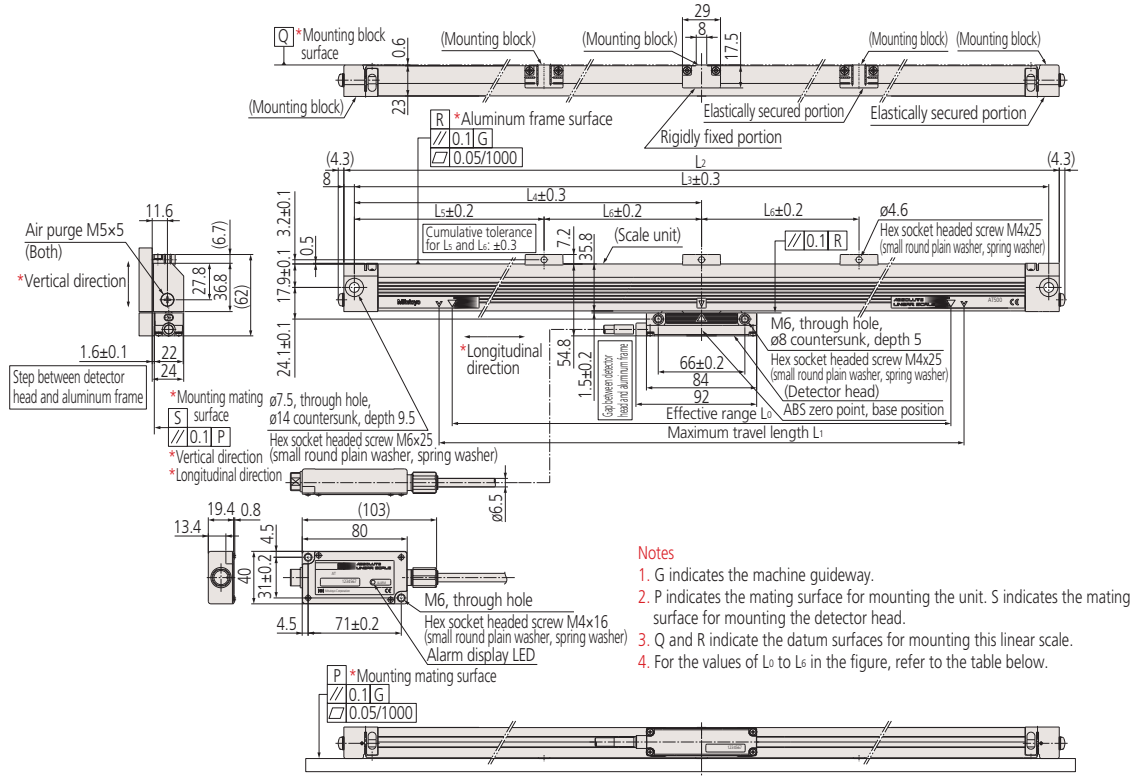

- Notes**
1. G indicates the machine guideway.
 2. P indicates the mating surface for mounting the unit. S indicates the mating surface for mounting the detector head.
 3. Q and R indicate the datum surfaces for mounting this linear scale.
 4. For the values of L_0 to L_6 in the figure, refer to the table below.

Dimension

Effective range L_0 (mm)	Maximum travel length L_1 (mm)	Overall length L_z (mm)	Mounting pitch			
			L_3 (mm)	L_4 (mm)	L_5 (mm)	L_6 (mm)
100	120	265	249	124.5	—	—
150	170	315	299	149.5	—	—
200	220	365	349	174.5	—	—
250	270	415	399	199.5	—	—
300	320	465	449	224.5	—	—
350	370	515	499	249.5	—	—
400	420	565	549	274.5	—	—
450	470	615	599	299.5	—	—
500	520	665	649	324.5	—	—
600	620	765	749	(374.5)	204.5	170
700	720	865	849	(424.5)	224.5	200
750	770	915	899	(449.5)	224.5	225
800	820	965	949	(474.5)	244.5	230
900	920	1065	1049	(524.5)	264.5	260
1000	1020	1165	1149	(574.5)	284.5	290

Codes and Order Numbers

• ABS AT553-HC

Order No.	Code
539-761-20	AT553- 100-HC
539-762-20	AT553- 150-HC
539-763-20	AT553- 200-HC
539-764-20	AT553- 250-HC
539-765-20	AT553- 300-HC
539-766-20	AT553- 350-HC
539-767-20	AT553- 400-HC
539-768-20	AT553- 450-HC
539-769-20	AT553- 500-HC
539-771-20	AT553- 600-HC
539-773-20	AT553- 700-HC
539-774-20	AT553- 750-HC
539-775-20	AT553- 800-HC
539-776-20	AT553- 900-HC
539-777-20	AT553-1000-HC

• ABS AT543/AT543A-HC

Order No.	Code
539-731-□□	AT543(A)- 100-HC
539-732-□□	AT543(A)- 150-HC
539-733-□□	AT543(A)- 200-HC
539-734-□□	AT543(A)- 250-HC
539-735-□□	AT543(A)- 300-HC
539-736-□□	AT543(A)- 350-HC
539-737-□□	AT543(A)- 400-HC
539-738-□□	AT543(A)- 450-HC
539-739-□□	AT543(A)- 500-HC
539-741-□□	AT543(A)- 600-HC
539-743-□□	AT543(A)- 700-HC
539-744-□□	AT543(A)- 750-HC
539-745-□□	AT543(A)- 800-HC
539-746-□□	AT543(A)- 900-HC
539-747-□□	AT543(A)-1000-HC

• ABS AT573A-HC

Order No.	Code
539-871-21	AT573A- 100-HC
539-872-21	AT573A- 150-HC
539-873-21	AT573A- 200-HC
539-874-21	AT573A- 250-HC
539-875-21	AT573A- 300-HC
539-876-21	AT573A- 350-HC
539-877-21	AT573A- 400-HC
539-878-21	AT573A- 450-HC
539-879-21	AT573A- 500-HC
539-881-21	AT573A- 600-HC
539-883-21	AT573A- 700-HC
539-884-21	AT573A- 750-HC
539-885-21	AT573A- 800-HC
539-886-21	AT573A- 900-HC
539-887-21	AT573A-1000-HC

• ABS AT503/AT503A-HC

Order No.	Code
539-161-□□	AT503(A)- 100-HC
539-162-□□	AT503(A)- 150-HC
539-163-□□	AT503(A)- 200-HC
539-164-□□	AT503(A)- 250-HC
539-165-□□	AT503(A)- 300-HC
539-166-□□	AT503(A)- 350-HC
539-167-□□	AT503(A)- 400-HC
539-168-□□	AT503(A)- 450-HC
539-169-□□	AT503(A)- 500-HC
539-171-□□	AT503(A)- 600-HC
539-173-□□	AT503(A)- 700-HC
539-174-□□	AT503(A)- 750-HC
539-175-□□	AT503(A)- 800-HC
539-176-□□	AT503(A)- 900-HC
539-177-□□	AT503(A)-1000-HC

* The □□ in the Order No. is as follows. AT543 : 20
AT543A: 21

* The □□ in the Order No. is as follows. AT503 : 10
AT503A: 11

Mounting dimensions (HL Type)

Unit: mm

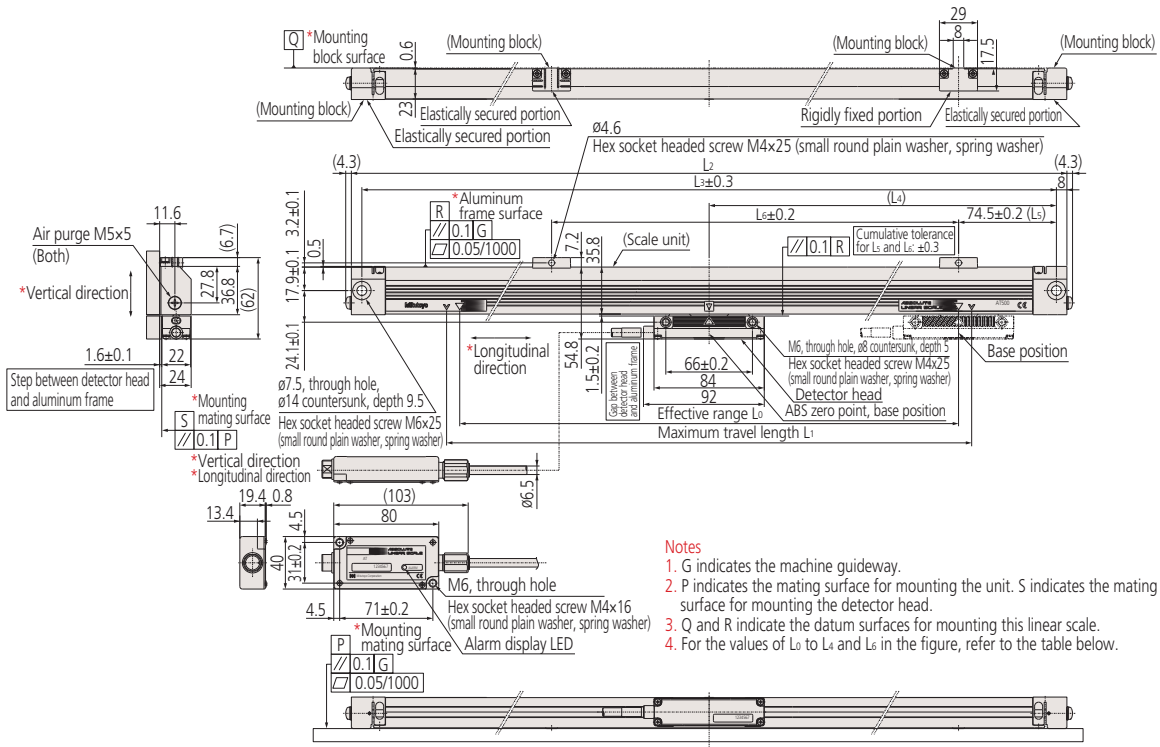

- Notes**
1. G indicates the machine guideway.
 2. P indicates the mating surface for mounting the unit. S indicates the mating surface for mounting the detector head.
 3. Q and R indicate the datum surfaces for mounting this linear scale.
 4. For the values of L₀ to L₄ and L₆ in the figure, refer to the table below.

Dimensions

Effective range L ₀ (mm)	Maximum travel length L ₁ (mm)	Overall length L ₂ (mm)	Mounting pitch		
			L ₃ (mm)	L ₄ (mm)	L ₆ (mm)
100	120	265	249	124.5	—
150	170	315	299	149.5	100
200	220	365	349	174.5	130
250	270	415	399	199.5	160
300	320	465	449	224.5	190
350	370	515	499	249.5	220

Codes and Order Numbers

• ABS AT553-HL

Order No.	Code
539-761-40	AT553-100-HL
539-762-40	AT553-150-HL
539-763-40	AT553-200-HL
539-764-40	AT553-250-HL
539-765-40	AT553-300-HL
539-766-40	AT553-350-HL

• ABS AT543/AT543A-HL

Order No.	Code
539-731-□□	AT543(A)-100-HL
539-732-□□	AT543(A)-150-HL
539-733-□□	AT543(A)-200-HL
539-734-□□	AT543(A)-250-HL
539-735-□□	AT543(A)-300-HL
539-736-□□	AT543(A)-350-HL

* The □□ in the Order No. is as follows. AT543 : 40
AT543A: 41

• ABS AT573A-HL

Order No.	Code
539-871-41	AT573A-100-HL
539-872-41	AT573A-150-HL
539-873-41	AT573A-200-HL
539-874-41	AT573A-250-HL
539-875-41	AT573A-300-HL
539-876-41	AT573A-350-HL

• ABS AT503/AT503A-HL

Order No.	Code
539-161-□□	AT503(A)-100-HL
539-162-□□	AT503(A)-150-HL
539-163-□□	AT503(A)-200-HL
539-164-□□	AT503(A)-250-HL
539-165-□□	AT503(A)-300-HL
539-166-□□	AT503(A)-350-HL

* The □□ in the Order No. is as follows. AT503 : 40
AT503A: 41

ABS AT500 Series

Structural Features

- **ABS AT500-S Series** combines high vibration resistance with shock resistance

1. Example of vibration resistance characteristics

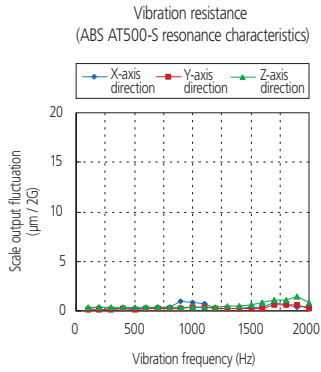

2. Vibration resistance

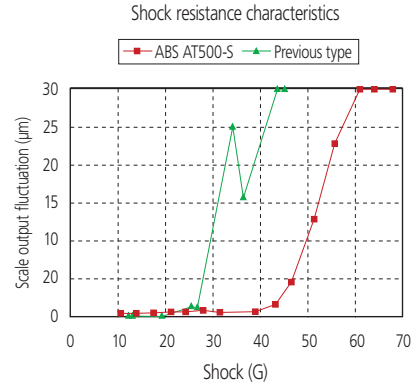

- **ABS AT500-H Series** combines outstanding thermal characteristics with high repeatability

1. Structural concept

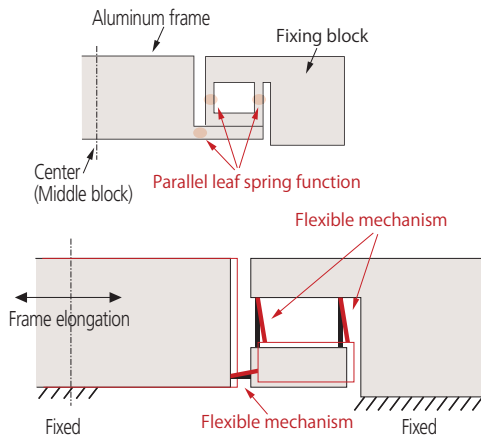

2. Example of thermal characteristics

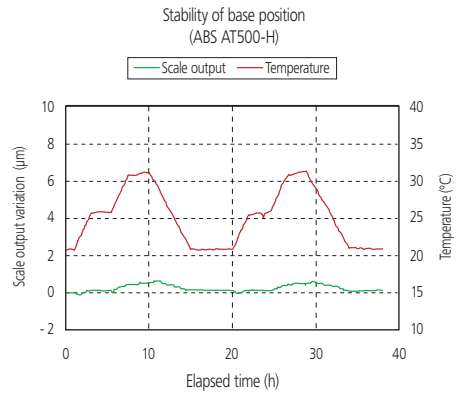

Note: This refers to the fixed point on the scale around which clamping arrangements ensure that any expansion or contraction due to temperature change occurs.

Assembly Type ABS AT Series

Absolute Scale Unit (Slim Spar Type)

ABS AT500E

(Resolution 0.005μm/0.05μm)

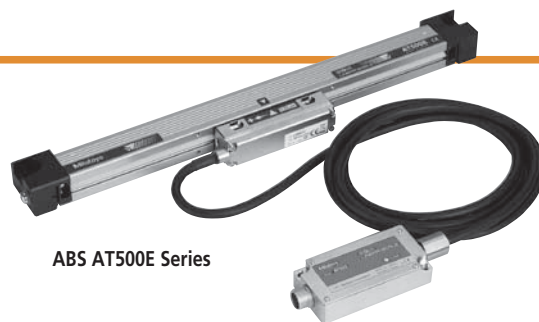

ABS AT500E Series

Features

- High-performance Absolute Linear Scale with 0.005μm/0.05μm resolution and high maximum response speed (72m/min, 150m/min).
- The ABS AT500E Series realizes vibration resistance of 147m/s² (15G) and shock-resistance of 343m/s² (35G), suitable for use with heavy cutting equipment and for high-speed machining.
- The ABS AT500E Series has high repeatability, excellent temperature characteristics, and enables highly accurate and stable positioning.
- Slim shape is suitable for space-saving designs.
- Compatible with servo amplifiers from a range of companies (high-speed serial interfaces).

How to read the code

ABS AT5 □ □ **E** - □ □ □ - **H** □

Effective range

Scale unit specifications
H: High-accuracy type

Base position for elongation of scale*

C: Midpoint of effective range
L: End of effective range (+ side end)
R: End of effective range (- side end)

* This refers to the fixed point on the scale around which clamping arrangements ensure that any expansion or contraction due to temperature change occurs.

Interface specification

Applicable systems	Scale code
FANUC Ltd. control devices FS-i Series POWER Mate i	ABS AT555E (Resolution 0.005μm) ABS AT553E (Resolution 0.05μm)
Mitsubishi Electric Corporation control devices MITSUBISHI CNC Series Applicable amplifier: MDS-D/MDS-DH Series	ABS AT545E (Resolution 0.005μm) ABS AT543E (Resolution 0.05μm)

Scale configuration

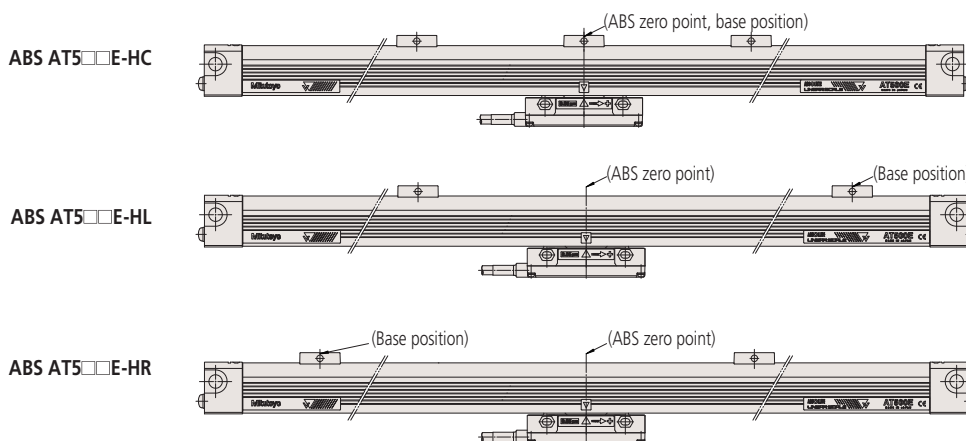

Specifications

Item	Code	ABS AT5□□E-HC	ABS AT5□□E-HL/HR
Detection method		Electrostatic capacitance type / photoelectric type composite ABS linear encoder	
How to mount the scale unit		3, 5 or 7-point elastic fixing	3 or 4-point elastic fixing
Base position		Midpoint of effective range	End of effective range HL: (+ side of absolute value) HR: (- side of absolute value)
Effective range		100 to 1220mm	100 to 350mm
Resolution		0.05μm/0.005μm (20μm/4096) *1	
Maximum response speed		150m/min (Resolution 0.05μm) 72m/min (Resolution 0.005μm)	
Accuracy (20°C)		(2+2L/1000)μm L: Effective range (mm)	
Thermal expansion coefficient		(8.5±0.5) x 10 ⁻⁶ /°C	
Vibration resistance		147 m/s ² (15G) (55 to 2000Hz)	
Shock resistance		353m/s ² (35G) (half-sine 11ms)	
Power supply voltage		DC5V±5%	
Maximum current consumption		270mA (Max)	
Maximum sliding force		4N	
Operating temperature/humidity		0 to 45°C, 20 to 80%RH (no condensation)	
Storage temperature/humidity		-20 to 70°C, 20 to 80%RH (no condensation)	
Protection rating		Scale unit: Equivalent to IP53, I/F box: not waterproof	
Alarm indication		Scale alarm indicated by LED on I/F Box	

*1: Because the 20μm signal is divided by 4096, the actual value is 0.0048828125μm. When setting the minimum resolution on the controller, always enter the actual value.

System configuration example (cable length)

(1) ABS AT5□3E

Unit: mm

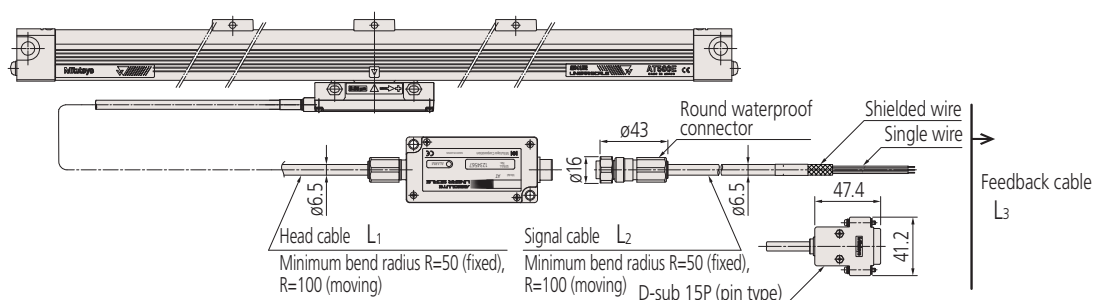

(2) ABS AT5□5E

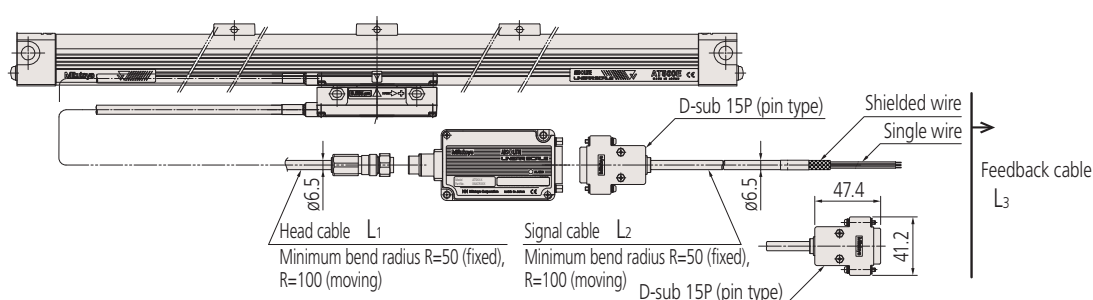

Allowable cable length for feedback cable L₃ (power supply voltage 5.0V)

1) Head cable L₁ = 2m (recommended standard length)

	Signal cable L ₂			
	3m (06ACT652A)	5m (06ACT652B)	8m (06ACT652C)	10m (06ACT652D)
Allowable length of cable L ₃ (Max.)	24m	19m	11m	- (N/A)
Total cable length	29m	29m	21m	12m

2) Head cable L₁ = 5m

	Signal cable L ₂			
	3m (06ACT652A)	5m (06ACT652B)	8m (06ACT652C)	10m (06ACT652D)
Allowable length of cable L ₃ (Max.)	21m	19m	11m	- (N/A)
Total cable length	29m	29m	24m	15m

3) Head cable L₁ = 10m

	信号ケーブルL ₂			
	3m (06ACT652A)	5m (06ACT652B)	8m (06ACT652C)	10m (06ACT652D)
Allowable length of cable L ₃ (Max.)	16m	14m	11m	- (N/A)
Total cable length	29m	29m	29m	20m

Notes

- 1: Feedback cable part numbers 7m: 06ACD238B, 9m: 06ACD238C, 10m: 06ACD238A, 12m: 06ACD238D
- 2: Feedback cable material: PVC sheathed (standard) or high-flex type (special order)
- 3: Signal cable (output side): single wire (standard) or D-sub 15P (special order)
- 4: Applicable connector for D-sub 15P: HDAB-15S (Hirose Electric or equivalent)

Output specification

• Signal cable with flying leads

Wire color	Signal
Brown/Red	+5V
White/Black	GND
Orange	SD
Yellow	SD
Green	REQ
Blue	REQ
Purple	Phase A
Gray	Phase B
Shield	FG

Notes

- 1: Phase A and Phase B are used as test signals. Keep them disconnected during use.
- 2: Connect the shield wire to the grounding conductor.

• Signal cable with D-sub connector

Pin No.	Signal
1, 2, 13	GND
3, 4, 11	+5V
5	SD
6	SD
7	REQ
8	REQ
9	Phase A
10	Phase B
15, Shell	FG
12, 14	Not used

Notes

- 1: Phase A and Phase B are used as test signals. Keep them disconnected during use.
- 2: Applicable connector: HDAB-15S (Hirose Electric or equivalent).

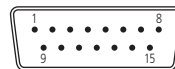

ABS zero point, base position and count direction

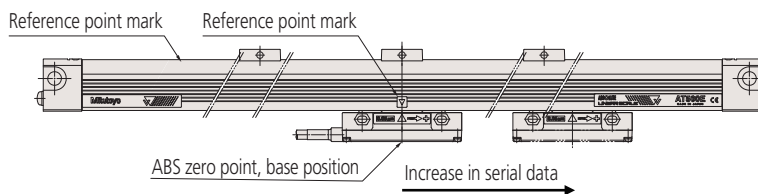

Cable dimensions

• ABS AT553E/AT543E

Unit: mm

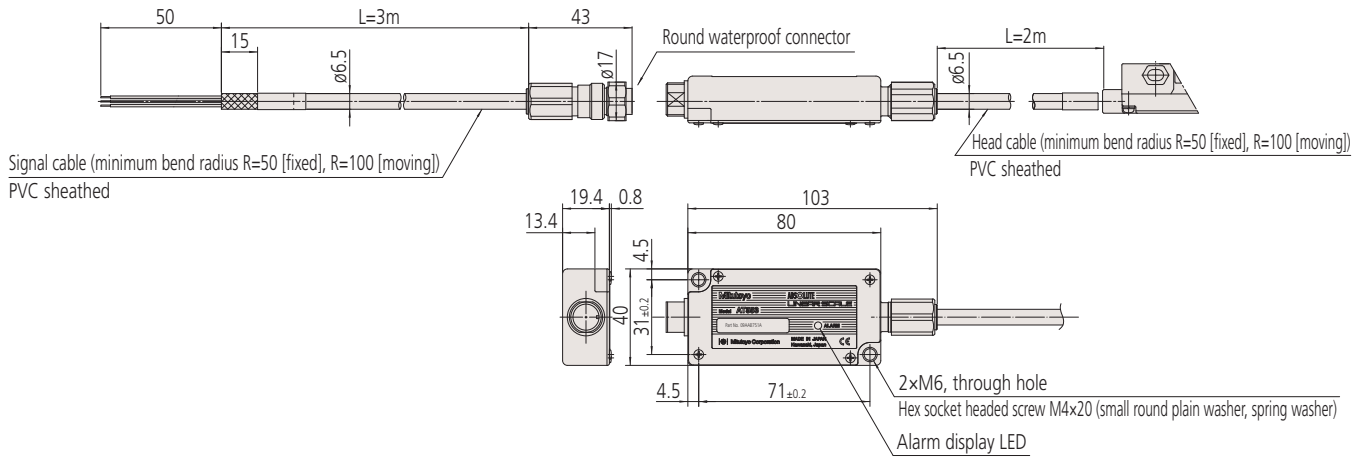

• ABS AT555A/AT545E

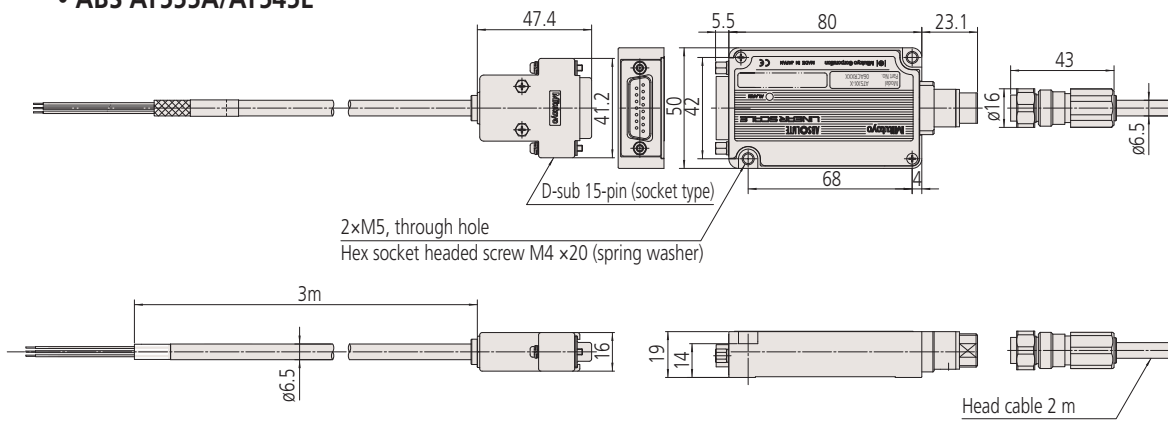

Mounting dimensions (HC Type) (Resolution 0.05μm)

Unit: mm

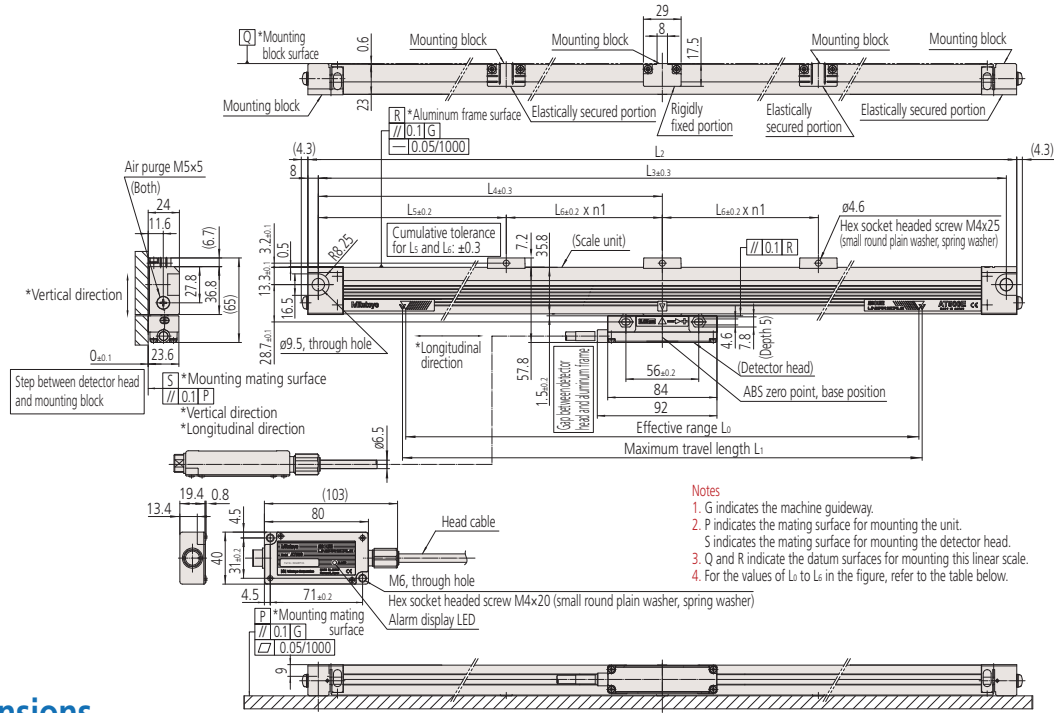

- Notes**
1. G indicates the machine guideway.
 2. P indicates the mating surface for mounting the unit.
 3. S indicates the mating surface for mounting the detector head.
 4. Q and R indicate the datum surfaces for mounting this linear scale.
 5. For the values of L_3 to L_6 in the figure, refer to the table below.

Dimensions

Effective range L_0 (mm)	Maximum travel length L_1 (mm)	Overall length L_2 (mm)	Mounting pitch				No. of mounting holes n
			L_3 (mm)	L_4 (mm)	L_5 (mm)	L_6 (mm)	
100	105	251	235	117.5	—	—	0
150	155	301	285	142.5	—	—	0
200	205	351	335	167.5	—	—	0
250	255	401	385	192.5	—	—	0
300	305	451	435	217.5	—	—	0
350	355	501	485	242.5	—	—	0
400	405	551	535	267.5	—	—	0
450	455	601	585	292.5	—	—	0
500	505	651	635	317.5	—	—	0
550	555	701	685	(342.5)	177.5	165	1
600	605	751	735	(367.5)	197.5	170	1
650	655	801	785	(392.5)	197.5	195	1
700	705	851	835	(417.5)	217.5	200	1
750	755	901	885	(442.5)	217.5	225	1
800	805	951	935	(467.5)	237.5	230	1
900	905	1051	1035	(517.5)	257.5	260	1
1000	1005	1151	1135	(567.5)	277.5	290	1
1120	1125	1274	1255	(627.5)	227.5	200	2
1220	1225	1371	1355	(677.5)	217.5	230	2

Codes and Order Numbers

• ABS AT553E-HC

Order No.	Code
539-761-22	AT553E- 100-HC
539-762-22	AT553E- 150-HC
539-763-22	AT553E- 200-HC
539-764-22	AT553E- 250-HC
539-765-22	AT553E- 300-HC
539-766-22	AT553E- 350-HC
539-767-22	AT553E- 400-HC
539-768-22	AT553E- 450-HC
539-769-22	AT553E- 500-HC
539-770-22	AT553E- 550-HC
539-771-22	AT553E- 600-HC
539-772-22	AT553E- 650-HC
539-773-22	AT553E- 700-HC
539-774-22	AT553E- 750-HC
539-775-22	AT553E- 800-HC
539-776-22	AT553E- 900-HC
539-777-22	AT553E-1000-HC
539-778-22	AT553E-1120-HC
539-779-22	AT553E-1220-HC

• ABS AT543E-HC

Order No.	Code
539-731-22	AT543E- 100-HC
539-732-22	AT543E- 150-HC
539-733-22	AT543E- 200-HC
539-734-22	AT543E- 250-HC
539-735-22	AT543E- 300-HC
539-736-22	AT543E- 350-HC
539-737-22	AT543E- 400-HC
539-738-22	AT543E- 450-HC
539-739-22	AT543E- 500-HC
539-740-22	AT543E- 550-HC
539-741-22	AT543E- 600-HC
539-742-22	AT543E- 650-HC
539-743-22	AT543E- 700-HC
539-744-22	AT543E- 750-HC
539-745-22	AT543E- 800-HC
539-746-22	AT543E- 900-HC
539-747-22	AT543E-1000-HC
539-748-22	AT543E-1120-HC
539-749-22	AT543E-1220-HC

Mounting dimensions (HC Type) (Resolution 0.005μm)

Unit: mm

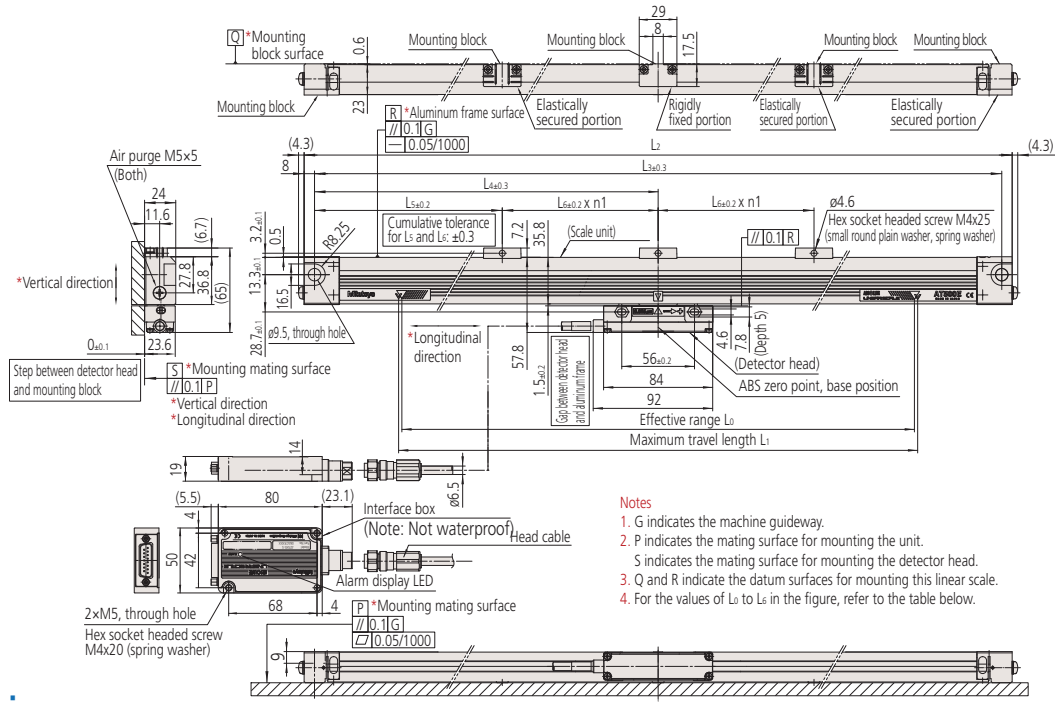

Dimensions

Effective range L ₀ (mm)	Maximum travel length L ₁ (mm)	Overall length L ₂ (mm)	Mounting pitch				No. of mounting holes n
			L ₃ (mm)	L ₄ (mm)	L ₅ (mm)	L ₆ (mm)	
100	105	251	235	117.5	—	—	0
150	155	301	285	142.5	—	—	0
200	205	351	335	167.5	—	—	0
250	255	401	385	192.5	—	—	0
300	305	451	435	217.5	—	—	0
350	355	501	485	242.5	—	—	0
400	405	551	535	267.5	—	—	0
450	455	601	585	292.5	—	—	0
500	505	651	635	317.5	—	—	0
550	555	701	685	(342.5)	177.5	165	1
600	605	751	735	(367.5)	197.5	170	1
650	655	801	785	(392.5)	197.5	195	1
700	705	851	835	(417.5)	217.5	200	1
750	755	901	885	(442.5)	217.5	225	1
800	805	951	935	(467.5)	237.5	230	1
900	905	1051	1035	(517.5)	257.5	260	1
1000	1005	1151	1135	(567.5)	277.5	290	1
1120	1125	1274	1255	(627.5)	(227.5)	200	2
1220	1225	1371	1355	(677.5)	(217.5)	230	2

Codes and Order Numbers

• ABS AT555E-HC

Order No.	Code
539-761-62	AT555E- 100-HC
539-762-62	AT555E- 150-HC
539-763-62	AT555E- 200-HC
539-764-62	AT555E- 250-HC
539-765-62	AT555E- 300-HC
539-766-62	AT555E- 350-HC
539-767-62	AT555E- 400-HC
539-768-62	AT555E- 450-HC
539-769-62	AT555E- 500-HC
539-770-62	AT555E- 550-HC
539-771-62	AT555E- 600-HC
539-772-62	AT555E- 650-HC
539-773-62	AT555E- 700-HC
539-774-62	AT555E- 750-HC
539-775-62	AT555E- 800-HC
539-776-62	AT555E- 900-HC
539-777-62	AT555E-1000-HC
539-778-62	AT555E-1120-HC
539-779-62	AT555E-1220-HC

• ABS AT545E-HC

Order No.	Code
539-731-62	AT545E- 100-HC
539-732-62	AT545E- 150-HC
539-733-62	AT545E- 200-HC
539-734-62	AT545E- 250-HC
539-735-62	AT545E- 300-HC
539-736-62	AT545E- 350-HC
539-737-62	AT545E- 400-HC
539-738-62	AT545E- 450-HC
539-739-62	AT545E- 500-HC
539-740-62	AT545E- 550-HC
539-741-62	AT545E- 600-HC
539-742-62	AT545E- 650-HC
539-743-62	AT545E- 700-HC
539-744-62	AT545E- 750-HC
539-745-62	AT545E- 800-HC
539-746-62	AT545E- 900-HC
539-747-62	AT545E-1000-HC
539-748-62	AT545E-1120-HC
539-749-62	AT545E-1220-HC

Mounting dimensions (HL Type) (Resolution 0.05µm/0.005µm)

Unit: mm

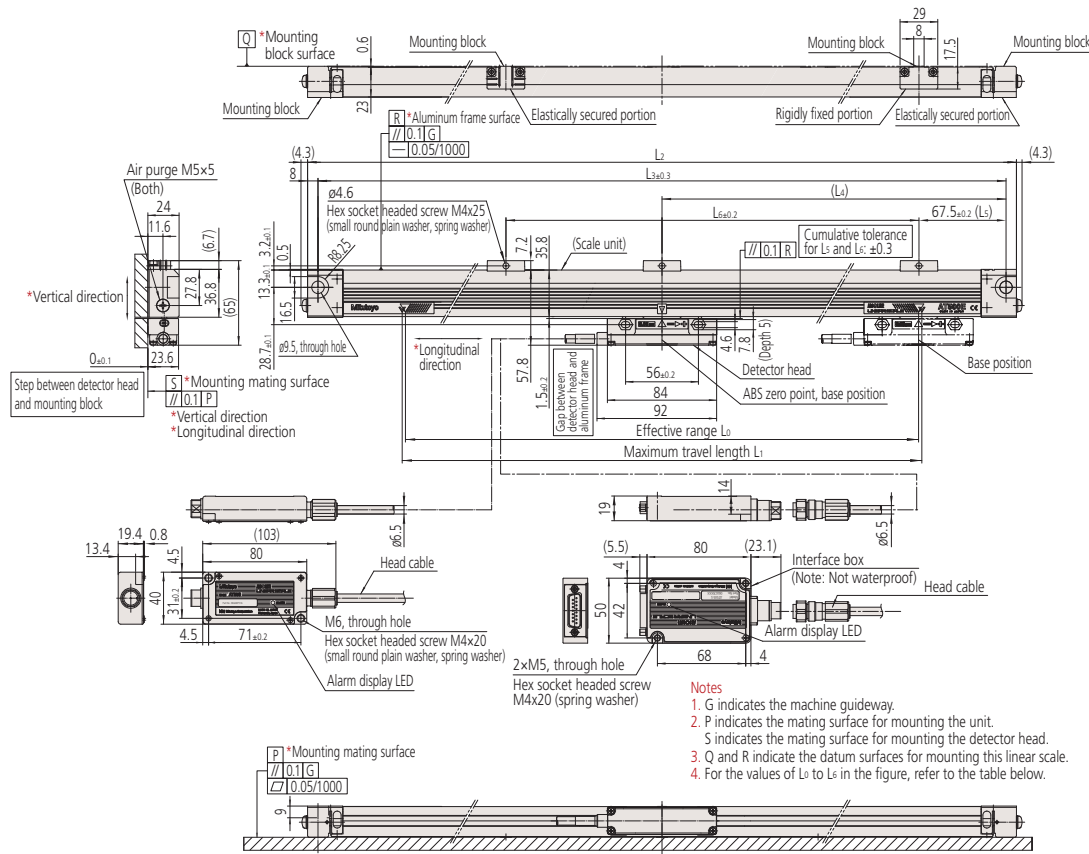

Dimensions

Effective range L ₀ (mm)	Maximum travel length L ₁ (mm)	Overall length L ₂ (mm)	Mounting pitch		
			L ₃ (mm)	L ₄ (mm)	L ₆ (mm)
100	105	251	235	117.5	—
150	155	303	285	142.5	100
200	205	351	335	165.5	130
250	255	401	385	192.5	160
300	305	451	435	217.5	190
350	355	501	485	242.5	220

Codes and Order Numbers

• ABS AT553E-HL

Order No.	Code
539-761-42	AT553E-100-HL
539-762-42	AT553E-150-HL
539-763-42	AT553E-200-HL
539-764-42	AT553E-250-HL
539-765-42	AT553E-300-HL
539-766-42	AT553E-350-HL

• ABS AT543E-HL

Order No.	Code
539-731-42	AT543E-100-HL
539-732-42	AT543E-150-HL
539-733-42	AT543E-200-HL
539-734-42	AT543E-250-HL
539-735-42	AT543E-300-HL
539-736-42	AT543E-350-HL

• ABS AT555E-HL

Order No.	Code
539-761-82	AT555E-100-HL
539-762-82	AT555E-150-HL
539-763-82	AT555E-200-HL
539-764-82	AT555E-250-HL
539-765-82	AT555E-300-HL
539-766-82	AT555E-350-HL

• ABS AT545E-HL

Order No.	Code
539-731-82	AT545E-100-HL
539-732-82	AT545E-150-HL
539-733-82	AT545E-200-HL
539-734-82	AT545E-250-HL
539-735-82	AT545E-300-HL
539-736-82	AT545E-350-HL

Absolute Scale Unit
ABS AT500 Series

Assembly Type ABS AT Series

Absolute Scale Unit (Standard Type)

ABSOLUTE™

ABS AT300 Series



ABS AT300 Series

Features

- Complete absolute type linear scales.
- Easy operation because no recalibration is required at startup or after a power failure.
- Suitable for position feedback in machinery requiring high-accuracy, high-speed control.
- Compatible with servo amplifiers from a range of companies (high-speed serial interfaces).

How to read the code

ABS AT3 -

Interface specification

Effective range

Applicable systems	Scale code
FANUC Ltd. control devices FS-i Series POWER Mate i	ABS AT353
Mitsubishi Electric Corporation control devices MITSUBISHI CNC Series Applicable amplifier: MDS-D/MDS-DH Series	ABS AT343
Mitsubishi Electric Corporation MR-J4/MR-J3 Series	ABS AT343A
Amplifier compatible with the Mitutoyo ENSIS interface Nikki Denso Co., Ltd. VCII/VC/VPS Series *1 Servoland Corporation SVF Series *1 PMAC JAPAN Co., Ltd. UMAC-Turbo PMAC2 Other machine types	ABS AT303A
	ABS AT303

*1 For connection to ABS AT303A

*ABS AT33

Communication method

Blank: Full-duplex communication

A: Half-duplex communication

* For details regarding the applicable system, please consult with the individual manufacturer.

Specifications

Item	Code	ABS AT353/AT343(A)/AT303(A)
Detection method		Electrostatic capacitance type / photoelectric type composite ABS linear encoder
Effective range		100 to 3000mm
Resolution		0.05 μm
Maximum response speed		120m/min (2m/s)
Accuracy (20°C)		100 to 1500mm: (3+3L ₀ /1000) μm 1600 to 3000mm: (5+5L ₀ /1000) μm L ₀ : Effective range (mm)
Thermal expansion coefficient		(8.0±1) x 10 ⁻⁶ /°C
Vibration resistance		98m/s ² (10G) (half-sine,11ms)
Shock resistance		147 m/s ² (15G) (55 to 2000Hz)
Power supply voltage		DC5V±5%
Maximum current consumption		250mA (Max)
Maximum sliding force		5N
Operating temperature/humidity		0 to 45°C, 20 to 80%RH (no condensation)
Storage temperature/humidity		-20 to 70°C, 20 to 80%RH (no condensation)
Protection rating		Equivalent to IP53
Signal cable length*		5m

* The AT343A signal cable is sold as an option.

0.2 m: **No.09BAA598A**

2 m: **No.09BAA598B**

3 m: **No.09BAA598C**

Output specification

• ABS AT353/AT343/AT303

Output connector (pin type): HDAB-15P (Hirose Electric)
 Applicable connector (included): HDAB-15S (Hirose Electric)
 Alternately, an equivalent product (D-sub series) can be used.

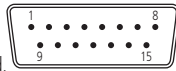

Pin No.	Signal
1	0V (GND)
2	0V (GND)
3	+5V
4	+5V
5	DT
6	DT
7	REQ
8	REQ
9	Phase A (for testing)
10	Phase B (for testing)
11	+5V
12	N.C
13	0V (GND)
14	N.C
15	F.G
Connector shell	F.G

Note: Phase A and Phase B are used as test signals.
 Keep them disconnected during use.

• ABS AT343A

Output connector (pin type): Tyco Electronics Japan
 Mini•Universal Mate-N-Lock Connector 9P
 172169-9 (Housing: Black)
 Applicable connector: 172161-9 (Housing: Black)

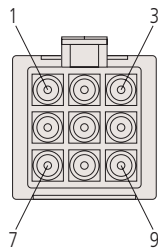

Pin No.	Signal
1	MR (RQ/DT)
2	MRR(RQ/DT)
3	N.C
4	(DT)
5	(DT)
6	N.C
7	P5 (+5V)
8	LG (GND)
9	F.G

Note: Phase A and Phase B are used as test signals.
 Keep them disconnected during use.

• ABS AT303A

Output connector (pin type): HDAB-15P (Hirose Electric)
 Applicable connector (included): HDAB-15S (Hirose Electric)
 Alternately, an equivalent product (D-sub series) can be used.



Pin No.	Signal
1	0V (GND)
2	0V (GND)
3	+5V
4	+5V
5	—
6	—
7	REQ/DT
8	REQ/DT
9	Phase A (for testing)
10	Phase B (for testing)
11	+5V
12	N.C
13	0V (GND)
14	N.C
15	F.G
Connector shell	F.G

Note: Phase A and Phase B are used as test signals.
 Keep them disconnected during use.

System configuration (See instruction manual)

• ABS AT353/AT343/AT303/AT303A

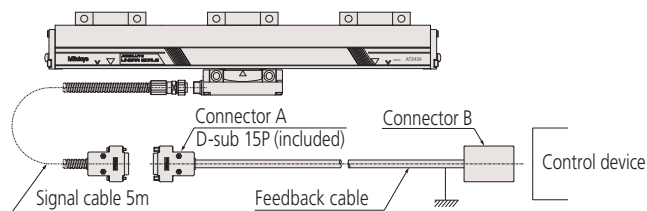

Notes

1. Connector B and the feedback cable are to be prepared by the user.
2. Connectors A/B and the grounding bar are to be connected by the user.
3. When fabricating a feedback cable, ensure that the total cable length is 25m or less.

• ABS AT343A

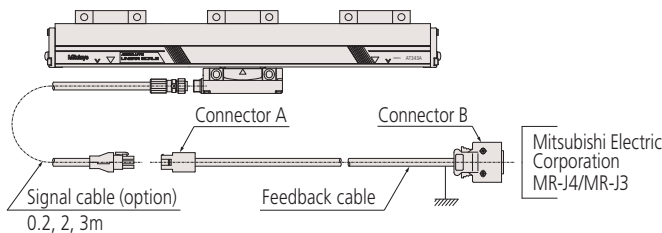

Notes

1. Connectors A/B and the feedback cable are to be prepared by the user.
2. Connectors A/B and the grounding bar are to be connected by the user.
3. A Mitsubishi Electric Corporation encoder cable can be used as the feedback cable.
 MR-J4/MR-J3 series compatible model: MREKCBL□M-H
 □ indicates the cable length (2, 5, 10m)
 * Depending on the signal cable length, the encoder cable length is restricted as follows.
 Signal cable 0.2 m: 2, 5, 10m
 Signal cable 2m: 2, 5m
 Signal cable 3m: 2m
 * The feedback cable configuration depends on the system. Please contact Mitsubishi Electric Corporation for details.

Mounting dimensions [ABS AT353/AT343(A)/AT303(A)]

Unit: mm

• Effective range 100 mm to 250mm

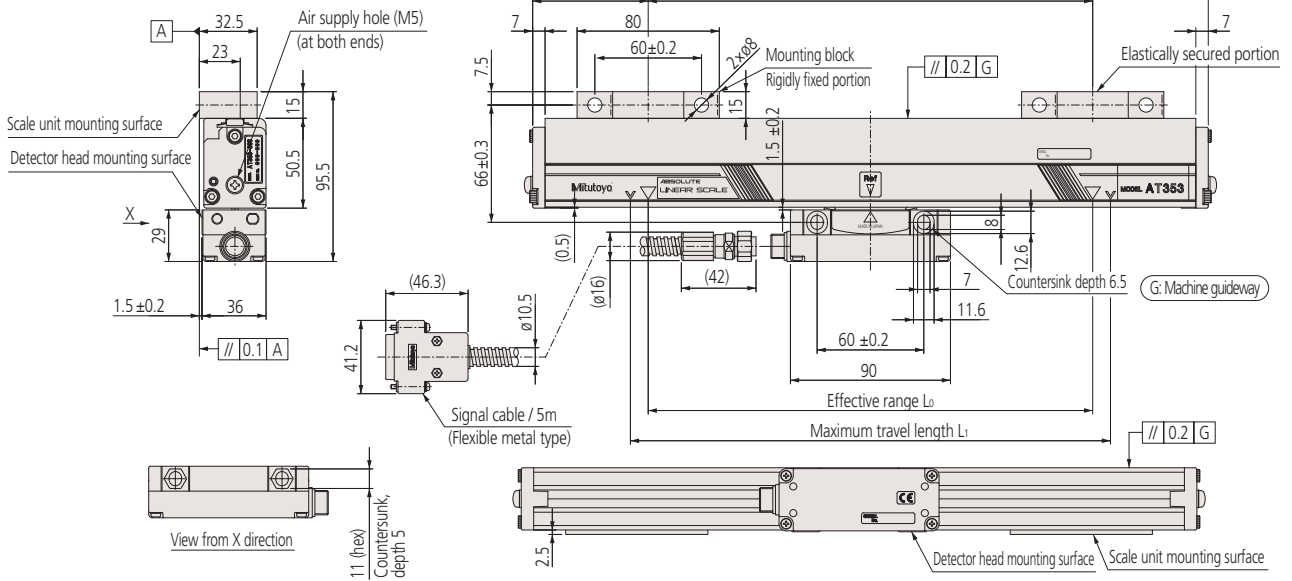

• ABS AT343A signal cable

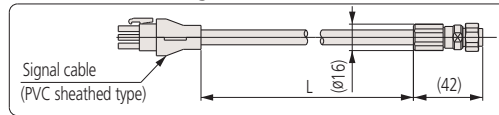

*The signal cable has set options.
(Part No.09BAA598A - C: 0.2m, 2m, 3m)

• Effective range 300mm to 3000mm

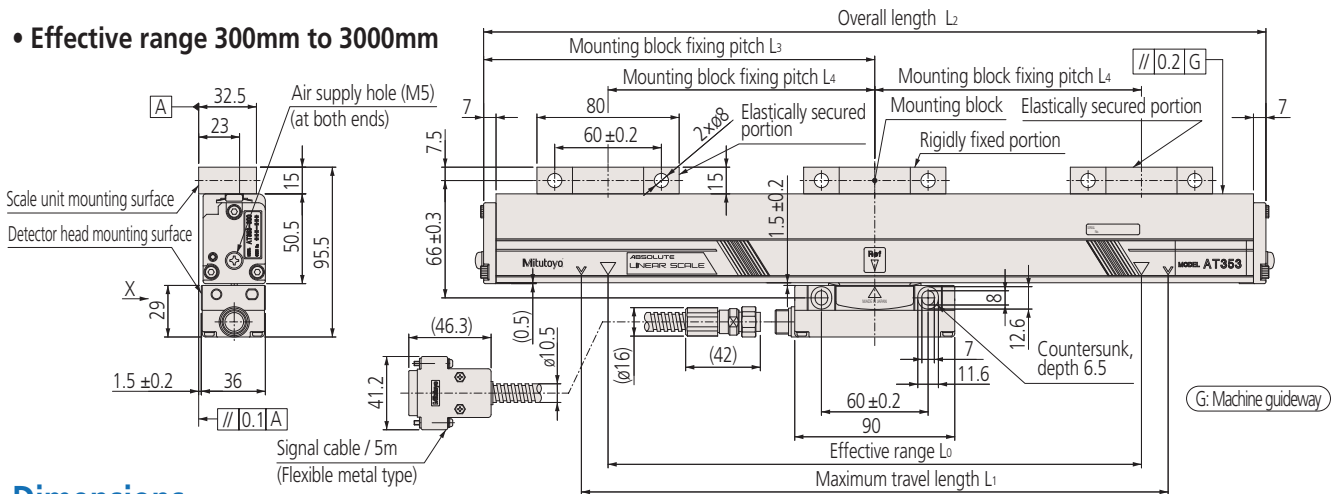

Dimensions

Effective range L ₀ (mm)	Maximum travel length L ₁ (mm)	Overall length L ₂ (mm)	Mounting block pitch		No. of mounting blocks
			L ₃ (mm)	L ₄ (mm)	
100	120	230	65	100	2
150	170	280	65	150	
200	220	330	65	200	
250	270	380	65	250	
300	330	440	220	150	
350	380	490	245	175	3
400	430	540	270	200	
450	480	590	295	225	
500	540	650	325	250	
600	650	760	380	300	
700	760	870	435	350	
750	810	920	460	375	
800	860	970	485	400	
900	960	1070	535	450	
1000	1060	1170	585	500	

Effective range L ₀ (mm)	Maximum travel length L ₁ (mm)	Overall length L ₂ (mm)	Mounting block pitch		No. of mounting blocks	
			L ₃ (mm)	L ₄ (mm)		
1100	1160	1270	635	275	5	
1200	1260	1370	685	300		
1300	1360	1470	735	325		
1400	1460	1570	785	350		
1500	1560	1670	835	375		
1600	1690	1800	900	400		
1700	1790	1900	950	425		
1800	1890	2000	1000	450		
2000	2100	2210	1105	335		7
2200	2300	2410	1205	370		
2400	2500	2610	1305	400		
2500	2600	2710	1355	315	9	
2600	2700	2810	1405	325		
2800	2900	3010	1505	350		
3000	3050	3210	1605	375		

Codes and Order Numbers

• ABS AT353

Order No.	Code	Order No.	Code
539-541-30	AT353- 100	539-558-30	AT353-1100
539-542-30	AT353- 150	539-559-30	AT353-1200
539-543-30	AT353- 200	539-560-30	AT353-1300
539-544-30	AT353- 250	539-561-30	AT353-1400
539-545-30	AT353- 300	539-562-30	AT353-1500
539-546-30	AT353- 350	539-563-30	AT353-1600
539-547-30	AT353- 400	539-564-30	AT353-1700
539-548-30	AT353- 450	539-565-30	AT353-1800
539-549-30	AT353- 500	539-566-30	AT353-2000
539-551-30	AT353- 600	539-567-30	AT353-2200
539-553-30	AT353- 700	539-568-30	AT353-2400
539-554-30	AT353- 750	539-569-30	AT353-2500
539-555-30	AT353- 800	539-570-30	AT353-2600
539-556-30	AT353- 900	539-571-30	AT353-2800
539-557-30	AT353-1000	539-572-30	AT353-3000

• ABS AT343/AT343A

Order No.	Code	Order No.	Code
539-601-□□	AT343(A)-100	539-618-□□	AT343(A)-1100
539-602-□□	AT343(A)-150	539-619-□□	AT343(A)-1200
539-603-□□	AT343(A)-200	539-620-□□	AT343(A)-1300
539-604-□□	AT343(A)-250	539-621-□□	AT343(A)-1400
539-605-□□	AT343(A)-300	539-622-□□	AT343(A)-1500
539-606-□□	AT343(A)-350	539-623-□□	AT343(A)-1600
539-607-□□	AT343(A)-400	539-624-□□	AT343(A)-1700
539-608-□□	AT343(A)-450	539-625-□□	AT343(A)-1800
539-609-□□	AT343(A)-500	539-626-□□	AT343(A)-2000
539-611-□□	AT343(A)-600	539-627-□□	AT343(A)-2200
539-613-□□	AT343(A)-700	539-628-□□	AT343(A)-2400
539-614-□□	AT343(A)-750	539-629-□□	AT343(A)-2500
539-615-□□	AT343(A)-800	539-630-□□	AT343(A)-2600
539-616-□□	AT343(A)-900	539-631-□□	AT343(A)-2800
539-617-□□	AT343(A)-1000	539-632-□□	AT343(A)-3000

*The □□ in the Order No. is as follows. AT343 : 30
AT343A : 31

• ABS AT303/AT303A

Order No.	Code	Order No.	Code
539-321-□□	AT303(A)-100	539-336-□□	AT303(A)-1100
539-322-□□	AT303(A)-150	539-337-□□	AT303(A)-1200
539-323-□□	AT303(A)-200	539-338-□□	AT303(A)-1300
539-324-□□	AT303(A)-250	539-339-□□	AT303(A)-1400
539-325-□□	AT303(A)-300	539-340-□□	AT303(A)-1500
539-326-□□	AT303(A)-350	539-341-□□	AT303(A)-1600
539-327-□□	AT303(A)-400	539-342-□□	AT303(A)-1700
539-328-□□	AT303(A)-450	539-343-□□	AT303(A)-1800
539-329-□□	AT303(A)-500	539-344-□□	AT303(A)-2000
539-330-□□	AT303(A)-600	539-345-□□	AT303(A)-2200
539-331-□□	AT303(A)-700	539-346-□□	AT303(A)-2400
539-332-□□	AT303(A)-750	539-347-□□	AT303(A)-2500
539-333-□□	AT303(A)-800	539-348-□□	AT303(A)-2600
539-334-□□	AT303(A)-900	539-349-□□	AT303(A)-2800
539-335-□□	AT303(A)-1000	539-350-□□	AT303(A)-3000

*The □□ in the Order No. is as follows. AT303 : Blank
AT303A: 01

Discontinued models and succession models specification compatibility

○: Compatible
 △: Compatible (with limitations)
 ×: Not compatible

Separate type ST scales

Discontinued models	Current model	Scale grating pitch	Output signal specifications	Accuracy	Mounting dimensions	Output connector specification pin assignment
ST31A, ST32A	ST36A	○	○	○	×	○
ST33C	ST36C	○	○	○	×	×
ST41A/ST42A	ST24C	○	○	○	×	×
ST41B/ST42B	ST24C/ST24B	○	△*1	○	×	×
ST52B	ST422/ST46-EZA	○	○	○	×	×
ST62C	ST422/ST46-EZA	○	△*1	○	×	×
ST34C	ST36C	○	○	○	×	○
ST322	ST422	○	○	×	×	○
ST44B/ST44C	ST46-EZA	○	○	○	×	○
ST46	ST46-EZA	○	○	○	×	○
LHS21/23C	None	—	—	—	—	—

*1 Up/down pulse output cannot be supported.

Assembly type AT scales

Discontinued models	Current model	Scale grating pitch	Output signal specifications	Accuracy	Mounting dimensions	Output connector specification pin assignment
AT2-N	AT103	○	△*2	○	○	△*2
AT2-FN		○	△*2	○	○	△*2
AT11-N	AT113	○	△*2	○	○	△*2
AT11-FN		○	△*2	○	○	△*2
AT12-N	AT112	○	△*2	○	○	△*2
AT12		○	△*2	○	○	△*2
AT81-C	AT181	○	×	△*3	○	×
AT21-C	AT211	○	△*4	△*3	×	×
AT21		×	△*4	△*3	×	×
AT25		×	△*4	△*3	×	×
AT102	AT103	○	○	○	○	○
AT111	AT113	○	○	○	○	○
AT212	AT211	○	○	△*3	×	×

*2 This can only be supported with an adapter when connected to an old counter.

*3 This must be checked for each scale effective range.

*4 Compatible with the output signal of the pulse signal unit

Absolute scale unit

Discontinued models	Current model	Interface	Resolution	Maximum response speed	Mounting dimensions	Output connector specification pin assignment
AT3□2	ABS AT3□3	○	△*5	○	×	△*6
AT500 series	ABS AT500-S series	○	○	○	×	△*7
	ABS AT500-H series	○	○	○	×	△*7

*5 You can control this by changing the NC parameter settings. For details, contact your NC manufacturer.

*6 Check that pins No. 9 and 10 of the AT353 output connector are not connected before you make the connection.

*7 The AT543A is compatible. Other current models have flying lead specifications.

Pulse signal units

Discontinued models	Current model	Output signal specifications	Power supply specifications	Mounting dimensions	Output connector specification pin assignment
PSU-1/2	PSU-200*10	△*8	×	×	×
FPSU03 series		△*8	×	×	△*9
FPSU05 series		○	×	×	×
FPSU10 series		○	×	×	×
FPSU4		○	○	×	○
FPSU21 series		○	×	×	×
PSU11		△*8	×	×	△*9
PSU12/13		△*8	×	×	△*9
PSU14		○	○	×	○
PSU21 series		△*8	×	×	△*9
PSU-100 series		○	○	○	○
PDS11		△*8	×	×	△*9

*8 Only the 2-phase square wave signals output specifications are compatible.

*9 Only the connector shape is compatible.

*10 When changing to the PSU-200, the scale may also have to be changed.

Note 1: The compatibilities listed above refer to compatibility with the standard specifications.

Note 2: When you change to a current model, check the direction before you make the connection. If the direction is different, the device may go out of control.

Note 3: Contact us for information on models not listed here.

Handling linear scales

Mounting scales

1. AT scale mounting posture

The scale unit is designed so that it is difficult for contamination to enter the unit, but determine the mounting posture after considering the arrival directions of coolant and dust so that these substances do not come into direct contact with the aperture. Also, be sure to prepare a scale cover.

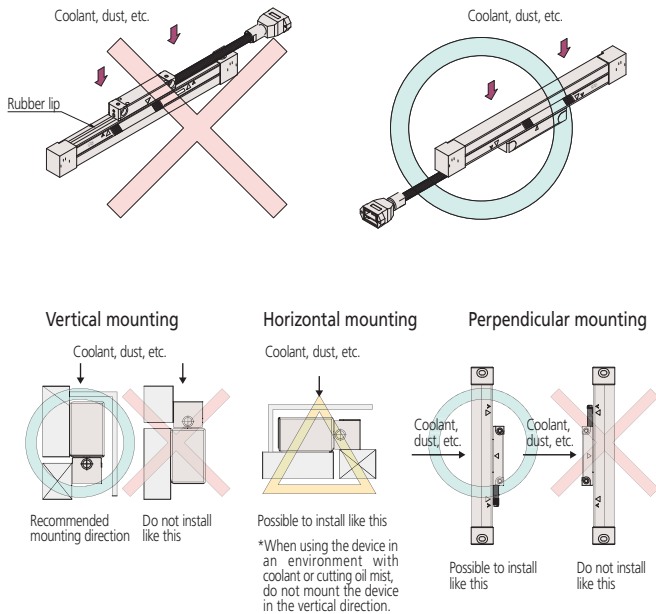

2. Mounting the AT scale unit

As shown in the following figure, use dial gauges or similar devices close to the two effective range marks to check and adjust their parallelism with the machine guideway.

To adjust the parallelism: (1) move the mechanically movable parts such as the slide table to adjust the parallelism of the scale unit or (2) measure the position from the mechanism's guide rail or from a corresponding reference.

- Permissible parallelism value: Less than 0.1mm or less than 0.2mm (This varies depending on the scale model.)

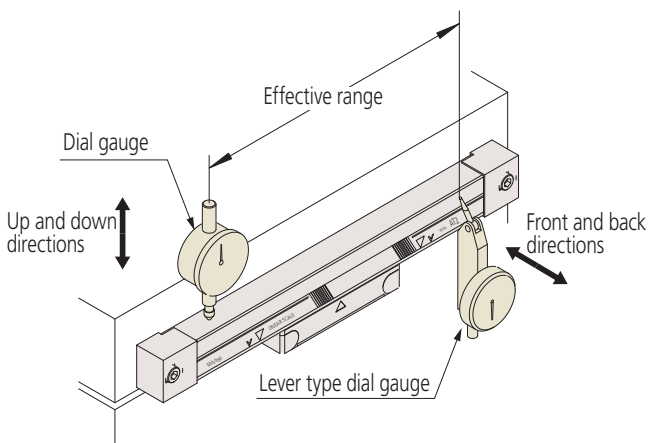

3. Cautions regarding mounting the ST scale (excluding the ABS ST700)

- Mount the main scale so that the detector head is facing the scale front surface (the surface on which rainbow colors are visible when light strikes the surface at an angle). (Models that have the Mitutoyo logo on the main scale are mounted correctly when the logo can be read from the detector head side.)
- Ambient light entering from the back of the main scale will cause incorrect operation, so the scale mounting design must ensure that ambient light does not enter.

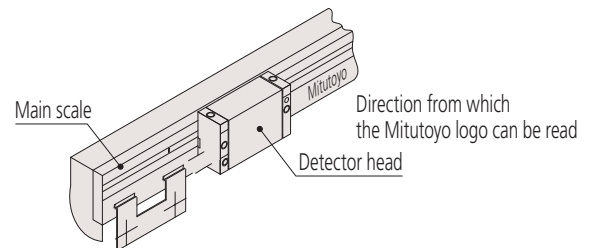

- Use a tool such as a lever type indicator or dial gage to move the head bracket and the scale mounting relatively in order to check whether the scale mounting surface has been prepared as shown in the mounting diagram.
- Use flexible adhesive with adhesive type scales. We recommend that you use KE441T manufactured by Shin-Etsu Chemical Co, Ltd.
- Remove the protective tape attached to the glass scale and detector head when you install the device.

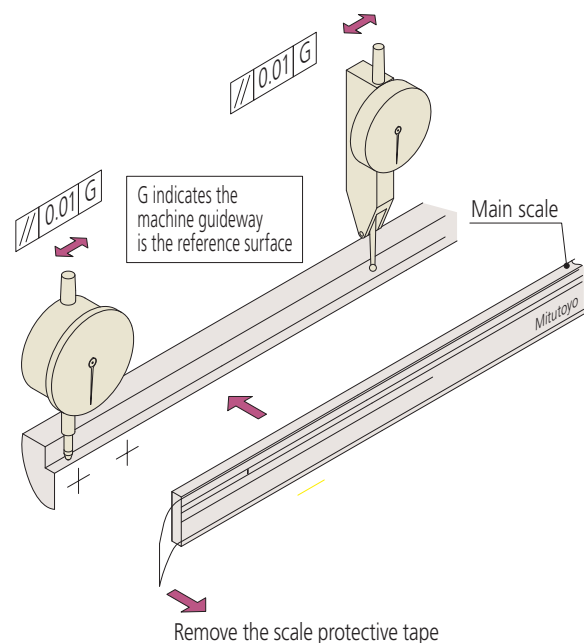

Technical Information

Structure and features of the assembly type linear scale (AT)

1. AT series detector joint mechanism (Adoption of simple joint structure offering high rigidity)

The detector head and slider (sensor) of the scale unit are connected by the joint shown in the following figure. Because of this structure, if values are less than or equal to the scale mounting standard values, detector head mounting errors and parallelism differences between the scale unit and the machine guideway are absorbed, and normal operation is assured. Also, the simple and highly rigid structure provides superior durability.

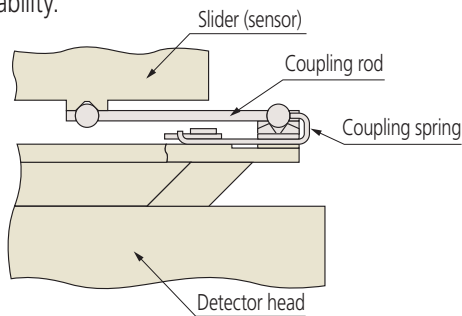

2. Advantage of special waterproof connectors

Adopting waterproof and oilproof connectors makes it possible to separate the signal cable. In turn, this makes installation and maintenance easy.

3. Signal cable conduit

Signal cables that are enclosed in a stainless-steel, spiral cover (conduit), for protection, are also available. The conduit will not rust or corrode, so these signal cables can be used over an extended period.

4. Adoption of rubber lip thrust method (Mitutoyo's proprietary technology)

The thrust part (see the following figure) pushes aside the rubber seal like a ship's keel pushes aside water.

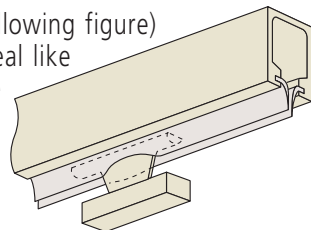

5. Adoption of specially formed urethane rubber lip with reinforcing wire

Resistance to oil and dust has been improved.

*Available with the AT103, AT203, ABS AT500, and ABS AT300.

*Can be specially ordered for the AT113 and AT211.

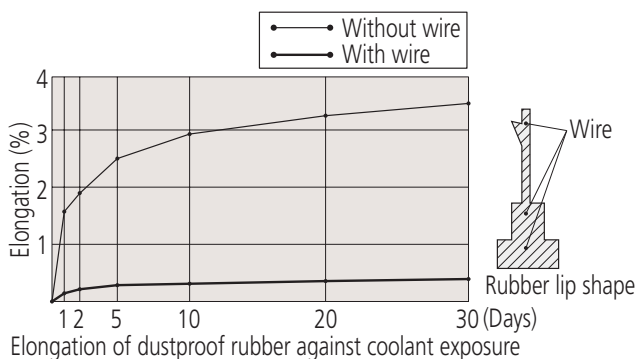

6. Maintenance of the seal

To maintain the dustproof property of the rubber seal and extend its life, apply a small amount of good-quality silicone grease (such as G-30L made by Shin-Etsu Chemical Co, Ltd.) to the contacting area of the rubber and detector head once a year. (The maintenance interval will vary slightly according to the operating conditions of the scale.)

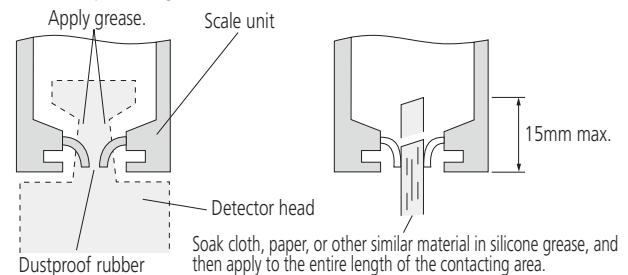

Durability of cables used with the linear scale

The life expectancy of the linear scale cables has been tested using the methods shown below.

Test method A

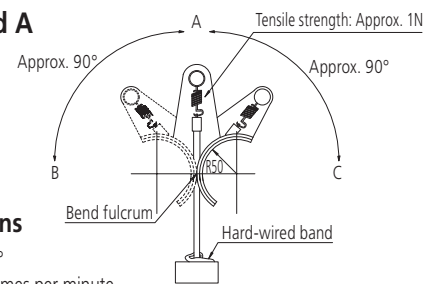

Test conditions

Bend angle: $\pm 90^\circ$

Test speed: 30 times per minute

(For the number of bends, A, B, A, C, and then A represents one bend.)

Bend radius: $R = 50\text{mm}$

Evaluation standard value: 3,000,000 times

(No breaks in the signal wires or shield)

Test method B

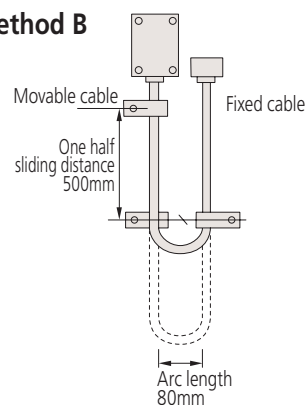

Test conditions

Bend radius: $R = 40\text{mm}$

Speed: 2m/s

Travel distance: 1000mm

Scales	Test method	Signal cable test result*1
AT100 series	A	3 million times
AT211	A	3 million times
AT202	A	3 million times
AT212	A	3 million times
AT300 series	A	3 million times
AT500 series	A	3 million times
ST700 series	B	54 million times or more*2
ST36	B	54 million times or more*2
ST24	B	54 million times or more*2
ST422	A	3 million times

*1 Also including the head cable

*2 Testing still ongoing as of December 2008

Note 1: The test data stated above does not represent guaranteed values.

Depending on the bend conditions, the number of times that the cables can bend without failure may be less than indicated.

Note 2: When bending cables, the recommended bend radius is 100mm or more.

Technical Information

Alarm functions

1. Detection of detector disconnection and short-circuit errors

Disconnection of and short circuits to 0V of the phase A and phase B signal lines from the linear scale as well as other similar errors are detected.

2. Detection of excess response speed of detector feed (over-speed)

The feed speed of the linear scale (detector) exceeding the maximum feed speed as well as other similar errors are detected.

3. Detection of input signal errors

The amplitude voltage, DC voltage, or phase difference of the phase A and phase B signals from the linear scale being outside of the corresponding allowable range as well as other similar errors are detected.

4. Drop in line voltage

The line voltage supplied to the linear scale, PSU, and other devices (particularly devices that use a DC power supply) dropping below the allowable range is detected as an error.

5. Detection of momentary power failures

A momentary power failure or voltage drop greater than the allowable range occurring in the power supply that is being supplied to the PSU, counter, or other device (devices that use an AC power supply) is detected as an error.

6. Detection of scale errors

Errors that occur inside the linear scale are detected.

7. Detection of detector circuit errors

Errors caused by the incremental count or absolute count in absolute linear scales are detected.

8. Detection of CPU errors (detection of internal errors)

For linear scales, counters, and other devices that use CPUs, the CPU stopping operating normally is detected as an error.

Note: The alarm functions vary according to the product. For details, see the alarm functions available with each product. Also note that the allowable ranges used to detect alarms vary according to the product.

Alarm detection functions available with each product

(1) Alarm functions on the AT scales (sinusoidal signal output type) + PSU-200



Scale code	Alarm function				
	Detected inside the scale		Detected inside the PSU		
	Scale error	Over-speed	Input signal error	Detection of scale errors	Disconnection or short circuit in signal cable
AT103	○	/	/	/	/
AT113	○	/	/	/	/
AT112	×	/	/	/	/
PSU-200	/	○	○	○	○
PSU-250 series	/	○	○	○	○

(2) Alarm functions on the AT scales (square wave signal output type)

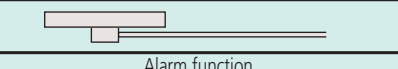

Scale code	Alarm function	
	Detected inside the detector head (inside the I/F on the AT212)	
	Over-speed	Input signal error
AT203	○	○
AT211	○	○
AT212	○	○

(3) Alarm functions on the ST scales (sinusoidal signal output type) + PSU-200



Scale code	Alarm function				
	Detected inside the scale		Detected inside the PSU		
	Scale error	Over-speed	Input signal error	Detection of scale errors	Disconnection or short circuit in signal cable
ST36A	○	/	/	/	/
ST24	○	/	/	/	/
PSU-200	/	○	○	○	○
PSU-250 series	/	○	○	○	○

(4) Alarm functions on the ST scales (square wave signal output type)



Scale code	Alarm function		
	Detected inside the I/F		
	Over-speed	Input signal error	Disconnection or short circuit in signal cable
ST24B(C)	○	○	○
ST36	○	○	○
ST422	○	○	○
ST46-EZA	○	○	○

(5) Alarm functions on the absolute scales

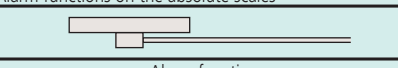

Scale code	Alarm function				
	Detected inside the I/F				
	Scale error	Over-speed	Input signal error	Detector circuit error	CPU error
ABS ST700 series	○	○	○	○	○
ABS AT300 series	○	○	○	○	○
ABS AT500 series	○	○	○	○	○

Explanation of terms

Linear scale accuracy

(1) Linear scale accuracy

As shown in Figure 1, the linear scale accuracy is determined by using an accuracy inspection device to perform comparisons at fixed intervals between the value measured with the linear scale and the reference value according to a laser length measuring device. The inspection environment temperature is 20°C, so the accuracy is at this temperature. The inspections are performed with other inspection conditions and standard values that comply with Mitutoyo's internal standards.

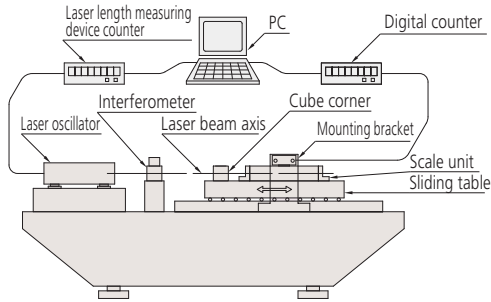

[Figure 1] Linear scale accuracy inspection device, overview

The accuracy (error) at each measured point is determined according to the following formula.

Error = reference value of the laser length measuring device - value measured by the linear scale

Here, the words "accuracy" and "error" have the same meaning.

We refer to the plot on a graph of the error at each measured point in the effective range as an accuracy chart.

Based on this accuracy chart, the accuracy of the linear scale is noted as the range between the maximum error and minimum error. There are the following two notation methods.

(1) Note the size of the range between the maximum error and minimum error as 'a'.

The value 'a' shown in Figure 2-1 indicates the accuracy. This standard value is indicated using the conversion formula $(\alpha + \beta)L \mu\text{m}$. Here, L is the effective range (in mm) and α and β are coefficients that are set on each model.

For example, for a linear scale with an accuracy standard value of $(3 + 3L/1000) \mu\text{m}$ and an effective range L of 1000mm, 'a' is $6 \mu\text{m}$.

(2) Note the size of the range between the maximum error and minimum error as $\pm a/2$.

The center value between the maximum error and minimum error is 0, the maximum value is noted as $+a/2$, the minimum value is noted as $-a/2$, and the size of the error range is noted as $\pm a/2$. This notation is mainly applied to ST scales. In notations (1) and (2), 'a' in (1) and $\pm a/2$ in (2) are the same accuracy standard value.

Linear scales use a straight-line scale that has fixed-pitch graduations as the reference to detect the amount of movement and the amount of change in position. By detecting graduations, a linear scale obtains 2-phase sinusoidal signals that have the same pitch as the graduations. The linear scale is designed so that it can perform readings with greater detail than the straight-line scale by interpolating this sine wave signal with an electronic circuit. Interpolation means that these 2-phase sinusoidal signals are interpolated, and the result is divided into pulse signals corresponding to the resolution. For example, if the graduation pitch is $20 \mu\text{m}$, readings can be performed with a resolution of $1 \mu\text{m}$.

Here, error within the graduation pitch range will occur according to the accuracy of this interpolation processing. This is called interpolation accuracy.

The accuracy standard value of a linear scale includes the aforementioned errors inspected at fixed intervals and interpolation accuracy.

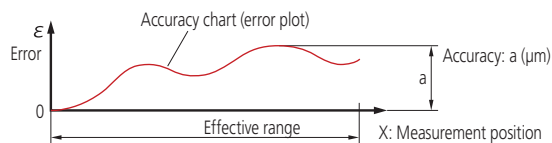

[Figure 2-1] Accuracy notation method (1)

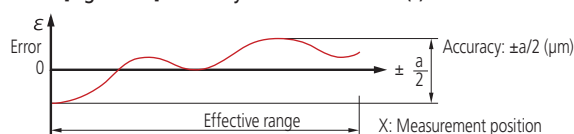

[Figure 2-1] Accuracy notation method (2)

Serial interface

This refers to a communication channel in which digital data is transmitted sequentially 1bit at a time. While it has inferior real-time characteristics, the advantages are that it requires less wiring and has high reliability. (This is the main communication method for feedback encoders.)

Line-driver output

This refers to signals that are output as square waves. A signal that has the inverted polarity of the output signal is generated, and the difference between these signals is set as the signal (differential signal output). This complies with EIA standards RS-422 and RS-485.

RS-422

This was standardized by the Electronic Industries Alliance (EIA) of the U.S. It is one of the balanced type serial communications standards, and it has excellent noise reducing characteristics. The maximum transmission speed is 10Mbps, but limitations on the transmission speed arise as the cable length increases.

RS-485

This was standardized by the Electronics Industries Alliance (EIA) of the U.S. It is one of the balanced type serial communications standards, and it ranks higher than RS-422. RS-422 is upwardly compatible with this standard. While RS-422 is a communication standard that supports point-to-point, multi-drop connections, this standard supports bus type multi-point connections and bidirectional communications.

Minimum edge interval

This refers to the minimum time between a rising edge or falling edge of a square wave being output (or input) and the next edge being output (or input). For square wave output type linear scales, even with the same resolution, the shorter the minimum edge interval, the faster the response speed.

Thermal expansion coefficient

This refers to the thermal expansion of an object in response to a change in temperature, which is measured as elongation per unit length for each 1°C increase in temperature of the material.

Full duplex communication and half duplex communication

Full duplex communication refers to a system in which devices (for example, a scale and a servo amplifier) each have two communication lines and can communicate with each other at the same time. On the other hand, half duplex communication refers to a system in which devices have a single communication line, so devices cannot communicate with each other at the same time, and communications can only be sent from a single device at any one time.

Full duplex communication

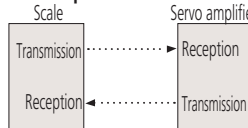

Half duplex communication

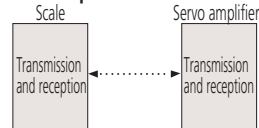

Protection rating definition

IP53 protection rating

Type	Protection ratings: Summary	Definition
Protection rating for external objects	5: Dustproof type	It is not possible to completely prevent the entry of dust, but dust cannot enter in amounts that interfere with the operation of electrical devices or that pose a safety hazard.
Protection rating for water	3: Protected against spraying water	Water sprayed at an angle up to 60° from the vertical shall have no harmful effect.

IP54 protection rating

Type	Protection ratings: Summary	Definition
Protection rating for external objects	5: Dustproof type	It is not possible to completely prevent the entry of dust, but dust cannot enter in amounts that interfere with the operation of electrical devices or that pose a safety hazard.
Protection rating for water	4: Protected against water splashes	Exposure to splashing water from all directions produces no harmful effect.

IP64 protection rating

Type	Protection ratings: Summary	Definition
Protection rating for external objects	6: Dustproof type	Prevents the entry of dust.
Protection rating for water	4: Protected against water splashes.	Exposure to splashing water from all directions produces no harmful effect.

IP65 protection rating

Type	Protection ratings: Summary	Definition
Protection rating for external objects	6: Dustproof type	Prevents the entry of dust.
Protection rating for water	5: Protected against water jets	Exposure to water projected from a nozzle from all directions produces no harmful effect.

IP67 protection rating

Type	Protection ratings: Summary	Definition
Protection rating for external objects	6: Dustproof type	Prevents the entry of dust.
Protection rating for water	7: Protection against the effects of immersion in water	Ingress of water in a harmful quantity shall not be possible when the enclosure is temporarily immersed in water under defined conditions of pressure and time.

Note: For the test conditions used to evaluate the protection ratings, see IEC 60529:2001 and JIS C 0920.



Export permission by the Japanese government may be required for exporting our products according to the Foreign Exchange and Foreign Trade Law. Please consult our sales office near you before you export our products or you offer technical information to a nonresident.

- Coordinate Measuring Machines
- Vision Measuring Systems
- Form Measurement
- Optical Measuring
- Sensor Systems
- Test Equipment and Seismometers
- Digital Scale and DRO Systems
- Small Tool Instruments and Data Management

Note: All information regarding our products, and in particular the illustrations, drawings, dimensional and performance data contained in this pamphlet, as well as other technical data are to be regarded as approximate average values. We therefore reserve the right to make changes to the corresponding designs, dimensions and weights. The stated standards, similar technical regulations, descriptions and illustrations of the products were valid at the time of printing. Only quotations submitted by ourselves may be regarded as definitive. Our products are classified as regulated items under Japanese Foreign Exchange and Foreign Trade Law. Please consult us in advance if you wish to export our products to any other country. If the purchased product is exported, even though it is not a regulated item (Catch-All controls item), the customer service available for that product may be affected. If you have any questions, please consult your local Mitutoyo sales office.

Mitutoyo Corporation
 20-1, Sakado 1-Chome,
 Takatsu-ku, Kawasaki-shi,
 Kanagawa 213-8533, Japan
 T +81 (0) 44 813-8230
 F +81 (0) 44 813-8231
<http://www.mitutoyo.co.jp>

